



# Vestil Manufacturing Company

2999 North Wayne Street, P.O. Box 507, Angola, IN 46703  
 Telephone: (260) 665-7586 -or- Toll Free (800) 348-0868  
 Fax: (260) 665-1339  
 Web: [www.vestil.com](http://www.vestil.com) e-mail: [info@vestil.com](mailto:info@vestil.com)

## CRP-SERIES CARPET RAMS



### Receiving Instructions

After delivery, remove the packaging from the product. Inspect the product closely to determine whether it sustained damage during transport. If damage is discovered, record a complete description of it on the bill of lading. If the product is undamaged, discard the packaging.

**NOTE:** The end-user is solely responsible for confirming that product design, use, and maintenance comply with laws, regulations, codes, and mandatory standards applied where the product is used.

### Technical Service & Replacement Parts

For answers to questions not addressed in these instructions and to order replacement parts, labels, and accessories, call our Technical Service and Parts Department at (260) 665-7586. The department can also be contacted online at <https://www.vestil.com/page-parts-request.php>.

### Electronic copies of Instruction Manuals

Additional copies of this instruction manual may be downloaded from <https://www.vestil.com/page-manuals.php>

Table of Contents		Page
Signal Words.....		2
Safety Instructions.....		2
Specifications.....		3
Exploded View & Bill of Materials.....		3
National Standards.....		4
Using the Carpet Ram.....		4
Record of Satisfactory Condition.....		4
Inspections.....		4 – 5
Maintenance.....		5
Labeling Diagram.....		5
Limited Warranty.....		6

## SIGNAL WORDS

SIGNAL WORDS appear in this manual to draw the reader's attention to important safety-related messages. The following are signal words used in this manual and their definitions.

### DANGER

Identifies a hazardous situation which, if not avoided, **WILL** result in **DEATH** or **SERIOUS INJURY**. Use of this signal word is limited to the most extreme situations.

### WARNING

Identifies a hazardous situation which, if not avoided, **COULD** result in **DEATH** or **SERIOUS INJURY**.

### CAUTION

Indicates a hazardous situation which, if not avoided, **COULD** result in **MINOR** or **MODERATE** injury.

### NOTICE

Identifies practices likely to result in product/property damage, such as operation that might damage the product.

## SAFETY INSTRUCTIONS

Vestil strives to identify foreseeable hazards associated with the use of its products, but no manual can address every conceivable risk. Minimize the likelihood of injury by observing the hazards identified below and by inspecting and maintaining the product as instructed in [INSPECTIONS & MAINTNENANCE](#) on p. 20.

### WARNING

Risks of serious personal injuries or death. Always apply material handling techniques learned during training and use the product properly.

- **Read and understand the entire manual before assembling, using or servicing the product.**
- Before using this (forklift) front end attachment, you must contact the manufacturers of all forklifts that will use it to request: 1) written approval; and 2) markings for each forklift that identify the coil carrier AND give the approximate weight of the forklift and carrier at maximum elevation with a laterally-centered load. **DO NOT use the carpet ram until your forklifts are marked.**
- Read and understand the entire manual before installing, using, or servicing the product. Read the manual to refresh your understanding of proper use, inspection, and maintenance procedures whenever necessary.
- DO NOT exceed the capacity of your unit. See [LABELING DIAGRAM](#), label 1153 on p. 5.
- Inspect the carpet pole before each use as described in [INSPECTIONS](#) on p. 4-5.
- Before attaching the carpet ram to the carriage of your fork lift, inspect the carriage and confirm that all parts are structurally sound and in [satisfactory condition](#). See [RECORD OF SATISFACTORY CONDITION](#) on p. 4.
- Always connect the safety chain to the carriage of your forklift without slack. The unit must not be able to slide on the forks.
- Verify that the load is stable by lifting the carpet just a few inches above the ground. Load swing should be minimal and the carpet pole should not shift on the forks. If the load is not stable while elevated, return it to the ground and use another device to transport it.
- ALWAYS apply the rules governing use of (forklift) front end attachments applied at your work site.
- DO NOT cover or remove any label. Verify the location and legibility of all labels. Label placement is shown in the [LABELING DIAGRAM](#) on p. 5. DO NOT use this device UNLESS all product labels are readable and undamaged.
- DO NOT ride or sit on the carpet pole.
- DO NOT use the carpet pole to push objects. Only use the product to transport a roll of carpet.
- ONLY use this product when traveling on firm, level, even ground.
- Carpet roll must not be longer than the pole. The carpet roll must not hang over the end of the pole. See [USING THE CARPET RAM](#) on p. 4 for loading instructions.
- DO NOT leave elevated rolls of carpet unattended. Always lower the load to the ground before leaving the forklift.
- DO NOT modify the carpet pole in any way UNLESS you first obtain written approval from Vestil. Unauthorized modifications automatically void the [LIMITED WARRANTY](#) (see p. 6) and might make the product unsafe to use.

### SPECIFICATIONS

Dimensions, net weight (lost load), and uniform capacity of each CCF-series coil carrier are provided in the following diagrams and table.

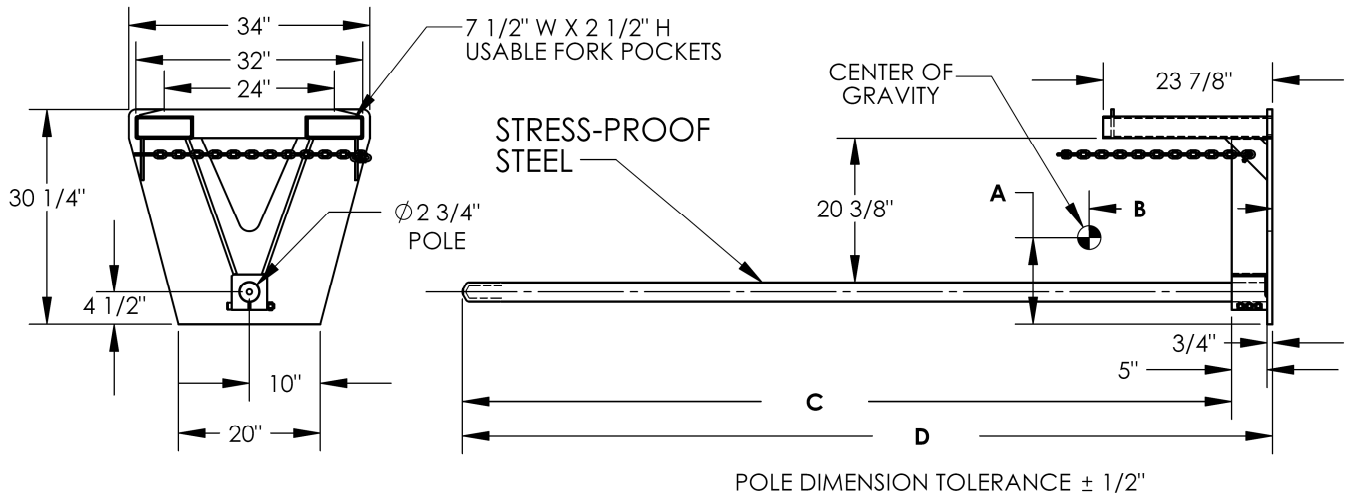

Model	A (Vertical center of gravity)	B (Horizontal center of gravity)	C	D	Uniform Capacity	Net Weight (Lost Load)
CRP-108	12 <sup>1</sup> / <sub>8</sub> " 30.8 cm	25 <sup>13</sup> / <sub>16</sub> " 65.6 cm	108 <sup>1</sup> / <sub>2</sub> " 275.6 cm	114 <sup>1</sup> / <sub>4</sub> " 290.2 cm	2,500 lb. (1,136.4 kg)	463 lb. (210.5 kg)
CRP-120	11 <sup>13</sup> / <sub>16</sub> " 30.0 cm	29 <sup>3</sup> / <sub>4</sub> " 75.6 cm	120 <sup>1</sup> / <sub>2</sub> " 306.1 cm	126 <sup>1</sup> / <sub>4</sub> " 320.7 cm	2,200 lb. (1,000 kg)	483 lb. (219.5 kg)
CRP-144	11 <sup>1</sup> / <sub>4</sub> " 28.6 cm	38" 96.5 cm	144 <sup>1</sup> / <sub>2</sub> " 367.0 cm	150 <sup>1</sup> / <sub>4</sub> " 381.6 cm	1,800 lb. (818.2 kg)	523 lb. (237.7 kg)

### EXPLODED VIEW AND BILL OF MATERIALS

08-006-055

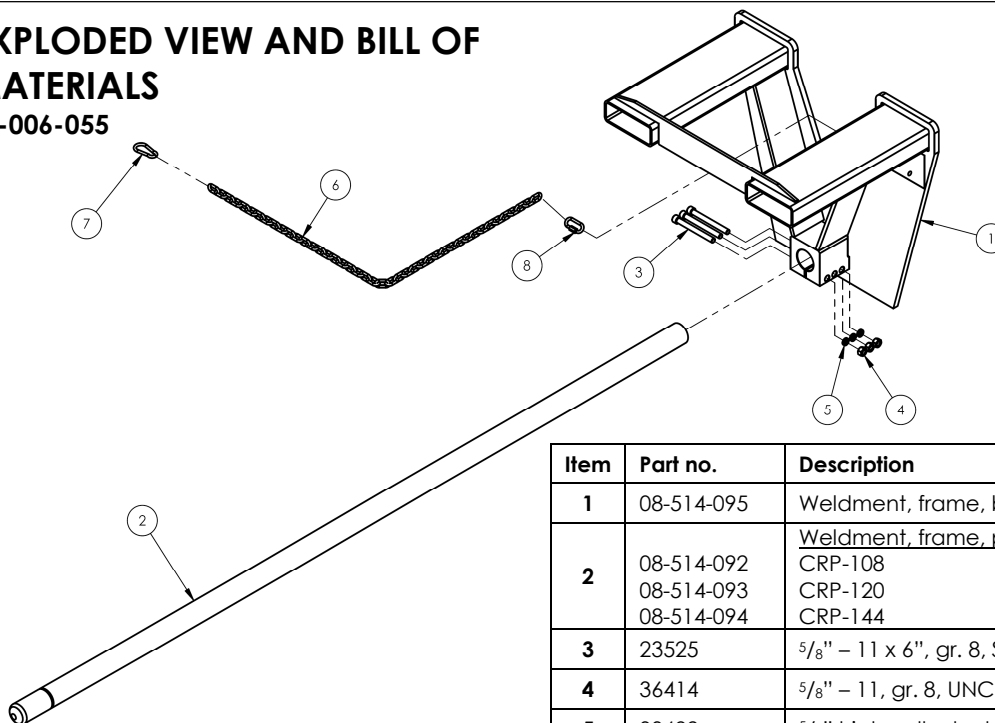

Item	Part no.	Description	Qty.
1	08-514-095	Weldment, frame, back plate	1
2	08-514-092	Weldment, frame, pole: CRP-108	1
	08-514-093	CRP-120	1
	08-514-094	CRP-144	1
3	23525	5/8" - 11 x 6", gr. 8, SCHS bolt	3
4	36414	5/8" - 11, gr. 8, UNC hex nut	3
5	33692	5/8" high collar lock washer	3
6	09-145-018	5/16" safety chain, 56" long	1
7	08-145-041	5/16" snap hook	1
8	99-145-053	5/16" quick link	1

## NATIONAL STANDARDS

According to US Federal Occupational Safety and Health Administration (OSHA) Rule 1910.178 (29 CFR 1910.178; the "Rule"), this device is a front end attachment for a lift truck whenever it is mounted on the forks of a lift truck. The Rule incorporates American National Standard ANSI/ITSDF B56.1 (the "Standard") published by the Industrial Truck Standards Development Foundation (ITSDF) on its website ([www.itsdf.org](http://www.itsdf.org)). The standard is freely downloadable at <http://www.itsdf.org/cue/b56-standards.html>. Before putting this drum carrier into service, you must acquire a copy of the Standard. Apply all relevant parts of Part II: For the User. **Lift truck users must mark/label the truck to identify the boom, show the weight of the truck and boom combination, and show the capacity of the truck with the boom at maximum elevation with the load laterally centered.** If instructions in this manual conflict with instructions in the Standard then the instructions in the Standard should be applied. Please contact our [TECHNICAL SERVICE](#) department if you believe that these instructions conflict with the Standard. Contact information for [TECHNICAL SERVICE](#) appears on the cover page of this manual.

## USING THE CARPET RAM

**Step 1:** Drive forward and insert the forks of your lift truck into the fork tubes of the frame. Drive until the frame contacts the heels of the forks. Drive until the ends of the fork pockets contact the heels of the forks. NOTE: In the photo (right), the forks have not been fully inserted to improve clarity of features.

**Step 2:** To prevent the ram from sliding on the forks, attach the safety chain ([item 6 on p. 3](#)) to the carriage of your lift truck *without slack*.

**Step 3:** Insert the pole into a roll of carpet. Drive forward until the end of the roll contacts the frame gussets. The yellow end of the pole must extend beyond the end of the roll. Do not use the carpet ram to lift and/or move a carpet roll unless the pole is long enough to extend beyond the end of the carpet roll.

**Step 4:** Raise the forks only as high as necessary to lift the roll of carpet off of the ground and to avoid contact with objects during transport. DO NOT leave a raised roll unattended. Always unload the carpet ram before leaving the forklift.

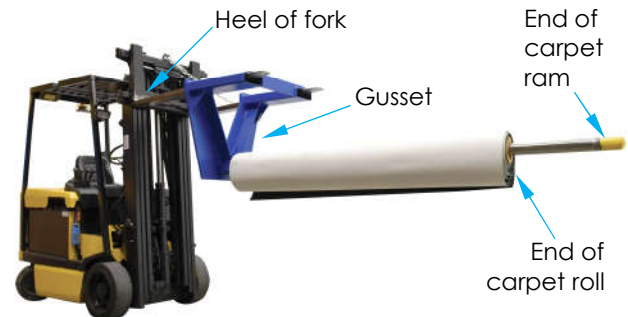

## RECORD OF SATISFACTORY CONDITION

Before using the ram for the first time, make a written record of its appearance. Describe the condition of the frame, pole, clamping bolts, safety chain, and snap hook. Take photographs of each item and add them to the record. Take photographs of all labels applied to the ram. Describe where each label is located. This record establishes satisfactory condition. When conducting the following inspections, compare your observations to the record to determine if a component is in satisfactory condition. Do not use the carpet ram unless every component is in satisfactory condition. Cosmetic changes, like damaged paint/powder coat do not constitute changes from satisfactory condition. However, touchup paint should be applied to all affected areas as soon as damage occurs.

## INSPECTIONS

Inspections and repairs should only be performed by qualified persons. Compare the results of each inspection to the [RECORD OF SATISFACTORY CONDITION](#) (the "RECORD"). Do not use the carpet ram unless all parts are in satisfactory condition. Replace parts that are not in satisfactory condition before returning the ram to service. **DON'T GUESS! If you have any questions about the condition of your ram, contact the [TECHNICAL SERVICE](#) department.** The phone number is provided on the cover page of this manual. *Never make temporary repairs of damaged or missing parts.* Only use manufacturer-approved replacement parts. Replace the entire unit if it cannot be restored to satisfactory condition.

**Before each use** — perform the following inspections.

1. Check the surface of the pole for dirt or other matter.
2. Confirm integrity of hardware & fasteners, i.e. bolts, nuts, pins, snap hook, quick link, et al.
3. Abnormal, unstable or noisy movement during use.
4. Examine pole and pole clamp for looseness or excessive wear, damage, or indications of metal fatigue.
5. Inspect the fork tubes for damage such as severe wear, thinned walls, significant corrosion, and warps.
6. Confirm that the safety chain is in satisfactory condition. Look for broken, elongated, and twisted links.
7. Check all labels. See [LABELING DIAGRAM](#) on p. 5. Replace labels that are damaged or not easily readable.
8. Examine the whole structure for rusting/metal erosion. Remove rust/corrosion with a steel bristle brush or steel wool. Clean the area and apply touchup paint.

**Annual evaluation** — At least once per year, authorized inspection personnel should use the carpet pole to lift a full capacity load. Afterwards, conduct a Frequent Inspection to confirm that the product is in satisfactory condition.

## MAINTENANCE

End-users should implement a maintenance program to ensure that the product functions properly and is adequately maintained. The OSHA “General Industry” standard for “Powered industrial trucks” ([29 CFR 1910.178](#)) provides recommended maintenance procedures for front end attachments. The following steps should be utilized in conjunction with those procedures. ONLY trained, authorized personnel or contractors should perform inspection, maintenance, or repair work.

**NOTE:** The end-user is responsible for selecting and training employees to work on the carpet ram. “Work on” means use, inspect, and maintain the product.

**Step 1:** Tag the ram, “Out of Service.”

**Step 2:** Remove any dirt or other matter from all surfaces.

**Step 3:** Conduct a “Before each use” inspection. If deformity, corrosion, rusting, or excessive wear is found, DO NOT use the product. Permanently remove it from service.

**Step 4:** Perform all necessary adjustments, replacements and/or repairs but DO NOT modify the ram.

**NOTE:** The reader should understand the significant difference between necessary adjustments and repairs, and modifications. An “adjustment” is a simple correction that restores the device to satisfactory condition, such as tightening loose fasteners, or removing dirt or other debris from the surface. “Repair” refers to removing worn parts and installing replacement parts. A “modification” is a change that alters the carpet pole from satisfactory condition, like bending the structural members or removing a part or several parts. **NEVER** modify the device without the express, written approval of Vestil. Modifications might make the device unsafe to use and automatically void the [LIMITED WARRANTY](#) on p. 6.

**Step 5:** Make a dated record of any repairs, adjustments and/or replacements.

## LABELING DIAGRAM

The unit should be labeled as shown in the diagram. Label content and location are subject to change so your product might not be labeled exactly as shown. Compare this diagram to your [RECORD OF SATISFACTORY CONDITION](#). Replace all labels that are damaged, missing, or not easily readable (e.g. faded). Order replacement labels by contacting the [TECHNICAL SERVICE & PARTS DEPARTMENT](#) online at <https://www.vestil.com/page-parts-request.php>. Alternatively, you may request replacement parts and/or service by calling (260) 665-7586 and asking the operator to connect you to the [PARTS DEPARTMENT](#).

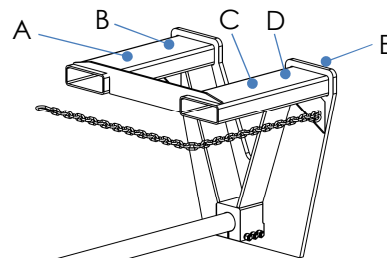

A: Label 985 (Proper installation)

⚠ WARNING	⚠ ADVERTENCIA
Serious personal injury might result if this product is installed or used improperly. <ul style="list-style-type: none"> <li>This side UP.</li> <li>ALWAYS install carpet ram according to instruction manual.</li> <li>When installed correctly, bolts clamping pole to backplate are below pole.</li> <li>DO NOT ride or sit on carpet ram.</li> <li>DO NOT use carpet ram to push, pull, or drag another object.</li> <li>DO NOT leave elevated roll of carpet unattended.</li> </ul>	Daños serios al personal podrían ser el resultado si este producto se instala o utiliza incorrectamente. <ul style="list-style-type: none"> <li>Esta parte hacia ARRIBA.</li> <li>SIEMPRE instale el recolector de alfombras de acuerdo con le manual de instrucciones.</li> <li>NO ande o se siente en el recolector de alfombras.</li> <li>NO use el recolector de alfombras para empujar, tirar, o arrastrar ningún objeto.</li> <li>NO deje el elevado rollo de alfombra sin atender.</li> </ul>

B: Label 1049 (Forklift must be properly marked)

⚠ WARNING
Improper use of this fork attachment might result in death or serious injury. <ul style="list-style-type: none"> <li>Before using this fork attachment, US Federal regulation 29 CFR 1910.178 requires you to contact the manufacturer of your lift truck and request:                             <ol style="list-style-type: none"> <li>Written approval [29 CFR 1910.178(a)(4)]</li> <li>Markings for (fork) lift truck that:                                     <ul style="list-style-type: none"> <li>Identify the attachment;</li> <li>Give approximate weight of truck and attachment at maximum evaluation with laterally-centered load. [29 CFR 1910.178(a)(5)].</li> </ul> </li> </ol> </li> <li>DO NOT use UNTIL lift truck is marked with corrected capacity tags. 1049</li> </ul>

C: Label 1053 (Model, serial no., wt., capacity)

MODEL / MODÉLO / MODÈLE _____
WEIGHT / PESO / MASS _____
CAPACITY / CAPACIDAD / CAPACITÉ _____
SERIAL / SERIE / SÉRIE _____
UNITS: 2.2 lb. = 1kg      1" (or 1in.) = 2.54cm      1153

D: Label 218 (Fasten safety chain to carriage)

⚠ WARNING	⚠ ADVERTENCIAS
Improper use might result in death or serious personal injury. Attach device to fork carriage with safety chain/strap. <ul style="list-style-type: none"> <li>Drive lift truck forward until forks contact ends of fork pockets.</li> <li>Chain/straps must not be able to disconnect (slide free) from carriage.</li> <li>Safety chain/strap must be taut. Connect chain/strap to carriage via shortest line.</li> </ul>	El uso impropio puede resultar en muerte o heridas personales. Ajar aparato al mástil del montacargas con cadenas/correas. <ul style="list-style-type: none"> <li>Maneje el montacargas para adelante hasta que las cuñas hagan contacto con la orilla del bolsillo de las cuñas.</li> <li>La cadenas y correas no deben de deslizarse (soltarse) del mástil del montacargas.</li> <li>La cadena/correa de seguridad debe de estar apretado. Asegure la cadena/correa al mástil via la ruta mas corta.</li> </ul>

E: Label 1001 (This Side Up)

USE THIS SIDE UP ONLY

## LIMITED WARRANTY

Vestil Manufacturing Company ("Vestil") warrants this product to be free of defects in material and workmanship during the warranty period. Our warranty obligation is to provide a replacement for a defective, original part covered by the warranty after we receive a proper request from the Warrantee (you) for warranty service.

### Who may request service?

Only a warrantee may request service. You are a warrantee if you purchased the product from Vestil or from an authorized distributor AND Vestil has been fully paid.

### Definition of "original part"?

An original part is a part used to make the product as shipped to the Warrantee.

### What is a "proper request"?

A request for warranty service is proper if Vestil receives: 1) a photocopy of the Customer Invoice that displays the shipping date; AND 2) a written request for warranty service including your name and phone number. Send requests by one of the following methods:

<u>US Mail</u>	<u>Fax</u>	<u>Email</u>
Vestil Manufacturing Corporation 2999 North Wayne Street, PO Box 507 Angola, IN 46703	(260) 665-1339 <u>Phone</u> (260) 665-7586	info@vestil.com Enter "Warranty service request" in subject field.

In the written request, list the parts believed to be defective and include the address where replacements should be delivered. After Vestil receives your request for warranty service, an authorized representative will contact you to determine whether your claim is covered by the warranty. Before providing warranty service, Vestil will require you to send the entire product, or just the defective part (or parts), to its facility in Angola, IN.

### What is covered under the warranty?

The warranty covers defects in the following original, dynamic parts: motors, hydraulic pumps, electronic controllers, switches, and cylinders. It also covers defects in original parts that wear under normal usage conditions ("wearing parts"), such as bearings, hoses, wheels, seals, brushes, and batteries.

### How long is the warranty period?

The warranty period for original dynamic components is 90 days. For wearing parts, the warranty period is 90 days. Both warranty periods begin on the date Vestil ships the product to the Warrantee. If the product was purchased from an authorized distributor, the periods begin when the distributor ships the product. Vestil may, at its sole discretion, extend a warranty period for products shipped from authorized distributors by up to 30 days to account for shipping time.

### If a defective part is covered by the warranty, what will Vestil do to correct the problem?

Vestil will provide an appropriate replacement for any covered part. An authorized representative of Vestil will contact you to discuss your claim.

### What is not covered by the warranty?

The Warrantee (you) are responsible for paying labor costs and freight costs to return the product to Vestil for warranty service.

### Events that automatically void this Limited Warranty.

- Misuse;
- Negligent assembly, installation, operation or repair;
- Installation/use in corrosive environments;
- Inadequate or improper maintenance;
- Damage sustained during shipping;
- Collisions or other accidents that damage the product;
- Unauthorized modifications: Do not modify the product IN ANY WAY without first receiving written authorization from Vestil.

### Do any other warranties apply to the product?

Vestil Manufacturing Corp. makes no other express warranties. All implied warranties are disclaimed to the extent allowed by law. Any implied warranty not disclaimed is limited in scope to the terms of this Limited Warranty. Vestil makes no warranty or representation that this product complies with any state or local design, performance, or safety code or standard. Noncompliance with any such code or standard is not a defect in material or workmanship.

