



VESTIL MANUFACTURING CORP.
 2999 North Wayne Street, P.O. Box 507, Angola, IN 46703
 Telephone: (260) 665-7586 -or- Toll Free (800) 348-0868
 Fax: (260) 665-1339
 Web: www.vestilmfg.com e-mail: info@vestil.com

KNOCKDOWN HORIZONTAL CYLINDER STORAGE CABINET: CYL-H-16-KD ASSEMBLY AND MAINTENANCE MANUAL



Receiving instructions:

After delivery, remove the packaging from the product. Inspect the product closely to determine whether it sustained damage during transport. If damage is discovered, record a complete description of it on the bill of lading. If the product is undamaged, discard the packaging.

NOTE:

The end-user is solely responsible for confirming that product design, use, and maintenance comply with laws, regulations, codes, and mandatory standards applied where the product is used.

Replacement Parts and Technical Assistance:

If you have questions that are not addressed in these instructions and to order replacement parts, labels, and accessories, call (260) 665-7586 and ask for the Service and Parts Department. The department can also be contacted online at http://www.vestilmfg.com/parts_info.htm.

Table of Contents

Specifications.....	2
Signal Words.....	2
Hazards.....	2
Exploded View & Bill of Materials: CYL-H-8-KD.....	3
Exploded View & Bill of Materials: Attaching Adjacent CYL-H-8-KD Units.....	4
Assembly instructions.....	4, 5, 6, 7
Loading the Cabinet.....	7
Record of Satisfactory Condition.....	7
Inspections & Maintenance.....	7 - 8
Labeling Diagram.....	8
Limited Warranty.....	9

SPECIFICATIONS

Dimensions and other product specifications appear in the following table:

Model	Uniform cylinder capacity	Dimensions (W x L x H)	Net weight
CYL-H-4-KD	4 horizontal	30in. x 32in. x 35 ¹ / ₄ in. 76cm x 81cm x 89 ¹ / ₂ cm	160 lb. 72.7 kg
CYL-H-8-KD	8 horizontal	30in. x 32in. x 68 ¹ / ₄ in. 76cm x 81cm x 173cm	341 lb. 155 kg
CYL-H-16-KD	10 horizontal	60in. x 32in. x 68 ¹ / ₄ in. 152cm x 81cm x 173cm	493 lb. 224 kg
CYL-H8-V510-KD	5-10 vertical 8 horizontal	60in. x 32in. x 68 ¹ / ₄ in. 152cm x 81cm x 173cm	434 lb. 197.3 kg

SIGNAL WORDS

This manual uses SIGNAL WORDS to direct the reader's attention to important safety-related messages. These messages describe uses of the product that could result in personal injury or property damage. Each signal word corresponds to a specific hazard level. The following are definitions of signal words that might appear in this manual.



Identifies a hazardous situation which, if not avoided, WILL result in DEATH or SERIOUS INJURY. Use of this signal word is limited to the most extreme situations.



Identifies a hazardous situation which, if not avoided, COULD result in DEATH or SERIOUS INJURY.



Indicates a hazardous situation which, if not avoided, COULD result in MINOR or MODERATE injury.



Identifies practices likely to result in product/property damage, such as operation that might damage the product.

HAZARDS

We strive to identify foreseeable hazards associated with the use of our products. However, material handling is inherently dangerous and no manual can address every risk. The end-user ultimately is responsible for exercising sound judgment at all times.



Failure to store liquefied petroleum gases ("LPG or "LP-Gas") in a manner that complies with OSHA requirements in 29 CFR 1910.110 and 29 CFR 1926.153n (the "OSHA Rules") creates a serious safety hazard. To reduce the possibility that one or more LPG cylinders might be damaged and/or explode, only use the cylinder cabinet in a location that complies with all cylinder storage requirements in the OSHA Rules.



Improper or careless use of this product might result in serious personal injuries sustained by the operator and bystanders.

- **Failure to read and understand the entire manual before assembling, using or servicing the product constitutes misuse.** Read the manual to refresh your understanding of proper use and maintenance procedures as necessary.
- Inspect the cabinet regularly; DO NOT use it unless it is in normal condition. See [Inspections & Maintenance](#) recommendations on pages 7-8.
- DO NOT use the cabinet if the cylinder-supports sustain any structural damage. If structural damage is present, immediately tag the unit "Out of Service" and inform maintenance personnel about the problem.
- DO NOT modify this product in any way. Modifications automatically void the limited warranty and might make the cart unsafe to use.
- DO NOT store the cabinet in a location where water pools. Standing water might damage the feet of the cabinet which might cause instability.
- DO NOT use the cabinet UNLESS all labels are in place and readable. See [Labeling Diagram](#) on p. 8.
- DO NOT use the cabinet to store LPG cylinders if the cylinder supports or cabinet feet are structurally damaged. If damaged, the cabinet might fall over and any stored cylinder could be damaged. If you notice structural damage, immediately remove all cylinders, tag the cabinet "Out of Service", and report the problem to maintenance personnel.

Exploded View and Bill of Materials: CYL-H-16-KD 31-006-163

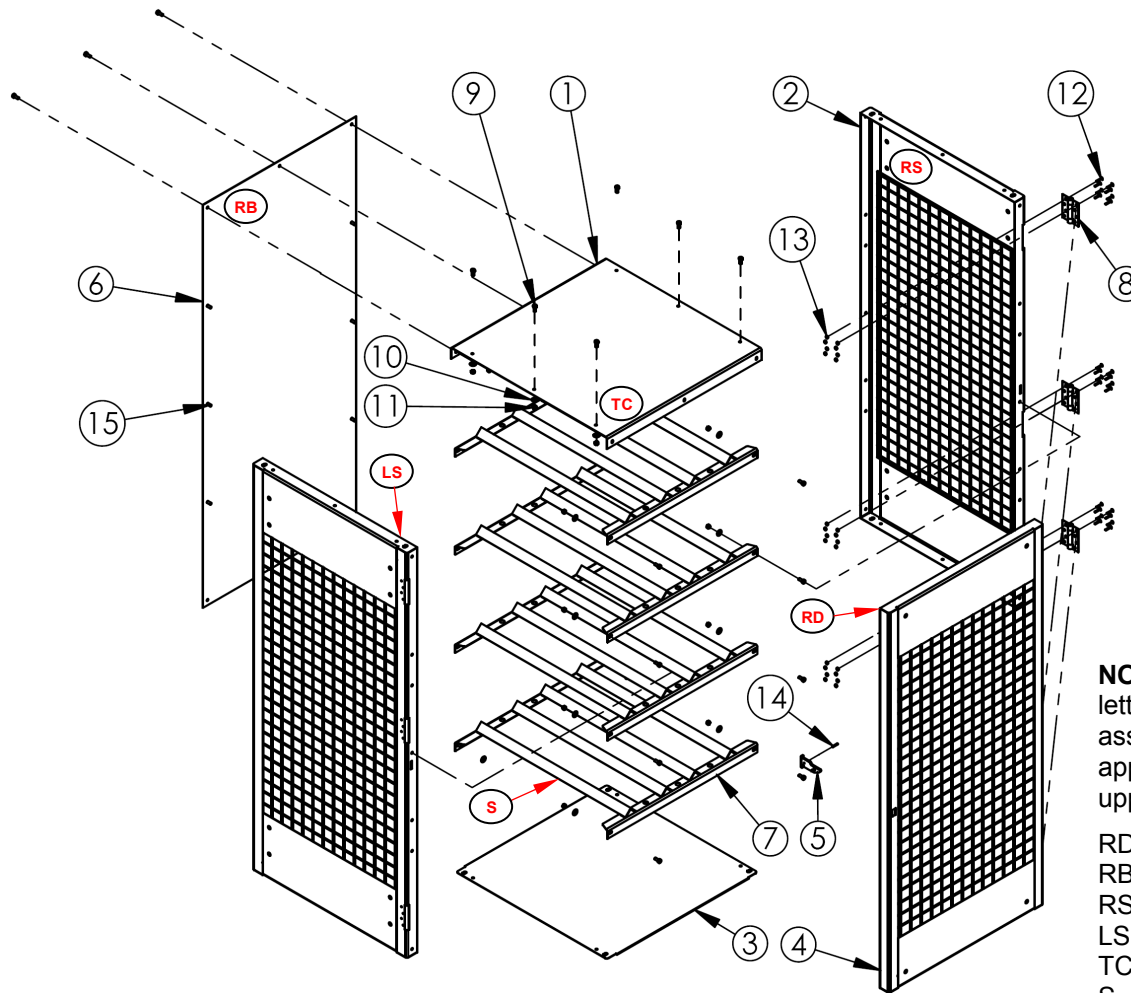

NOTE 1: The fully assembled, 16-cylinder cabinet consists of two (2) 8-cylinder cabinets. An exploded view of a single 8-cylinder cabinet is provided on this page. The two 8-cylinder cabinets are attached to each other with the hardware shown in the exploded view on the following page (4).

NOTE 2: Circled letters identify the assembly sticker applied to the inside, upper, left corner.

RD = Door
 RB = Back
 RS = Right Side
 LS = Left Side
 TC = Top Cap
 S = Shelf

Item	Part no.	Description	Quantity
1	31-014-357	Frame, top plate ("Top cap")	1
2	31-514-226	Weldment, frame, side panel ("Side panel")	2
3	31-014-356	Frame, base plate ("Base plate")	1
4	31-514-225	Weldment, door frame ("Door")	1
5	31-037-001	Latch, door	1
6	31-014-358	Frame, back plate ("Back panel")	1
7	31-514-227	Weldment, frame, shelf, horizontal ("Shelf")	4
8	31-012-002	4" stainless steel hinge	3
9	11053	⁵ / ₁₆ in. – 18 x ³ / ₄ in. HHCS #2 zinc-plated bolt	17
10	33006	⁵ / ₁₆ in. USS flat washer zinc-plated	19
11	36104	⁵ / ₁₆ in. – 18 hex nut zinc-plated	17
12	24213	Flat head socket cap screw #10-32 x 1in. (used to fasten hinge to side panel and door frame)	24
13	36030	10-32 hex nut (used to fasten hinges to side panels and door frame)	24
14	64133	Spring pin, ³ / ₁₆ in. x 1in.	1
15	99-145-100	Rivet, ⁵ / ₁₆ " x ³ / ₄ "	8

Exploded View and Bill of Materials: Attaching Adjacent 8-Cylinder Units 31-006-165

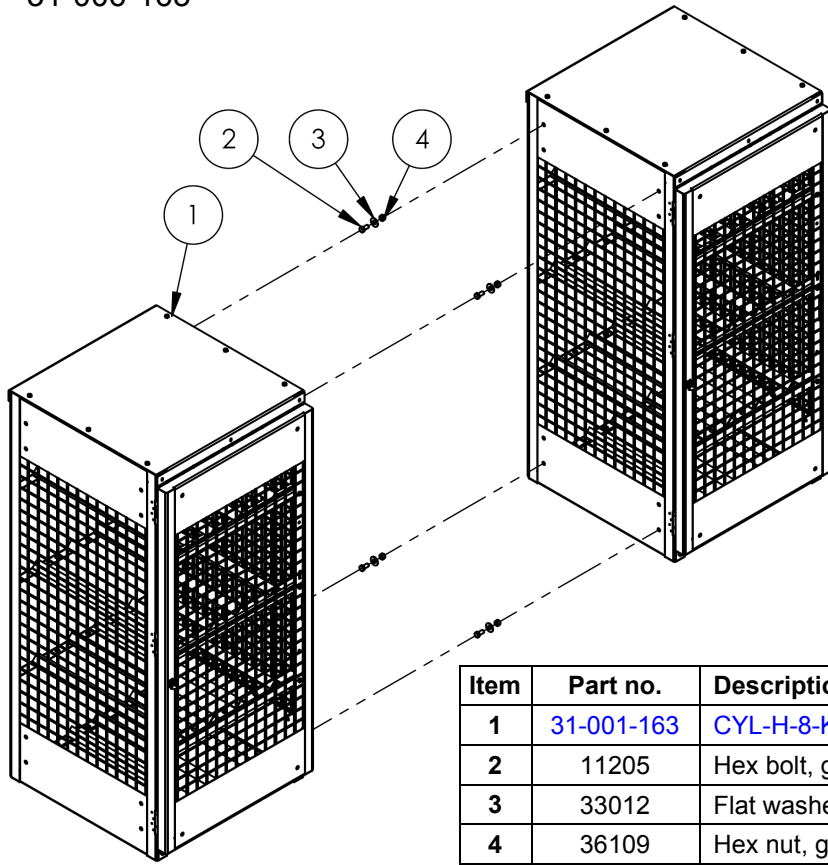

NOTE: Adjacent 8-cylinder units are fastened together to provide 16-cylinder storage capacity. The diagram and bill of materials (below) identify the hardware necessary to attach adjacent units.

Item	Part no.	Description	Qty.
1	31-001-163	CYL-H-8-KD assembly (Exploded View on p. 4)	2
2	11205	Hex bolt, grade A, zinc plated, 1/2" – 13 x 1"	4
3	33012	Flat washer, low carbon, zinc finish, 1/2"	4
4	36109	Hex nut, grade A, plain finish, 1/2" - 13	4

ASSEMBLY

Sixteen (16) cylinder storage cabinets are comprised of two (2) 8-cylinder cabinets fastened together. The following instructions sometimes depict only 1 cabinet. However, both cabinets should be assembled as described and illustrated.

[NOTE: Numbers in parentheses correspond to part numbers in the [exploded view](#) on p. 3.]

Step 1 – Fasten the back panel ([31-014-358](#)) to the side panels ([34-514-226](#)) with 5/16in. hardware ([11053](#); [33006](#); and [36104](#)). The back panel attaches to the outside of the side panels.

- Notice that one side of the back panel has only 2 bolt holes (there are three in each of the other sides). This is the bottom side of the back panel.
- Also notice that each side panel has an edge with 2 "hinge slots" cut out of it. This is the front edge of a side panel.
- Insert a 5/16in. – 18 x 3/4in. bolt ([11053](#)) through the middle and bottom holes in the back panel and the side panel as shown in the diagram to the right.
- Fasten the back panel to the other side panel in the same manner. Do not tighten the bolts and nuts at this time.

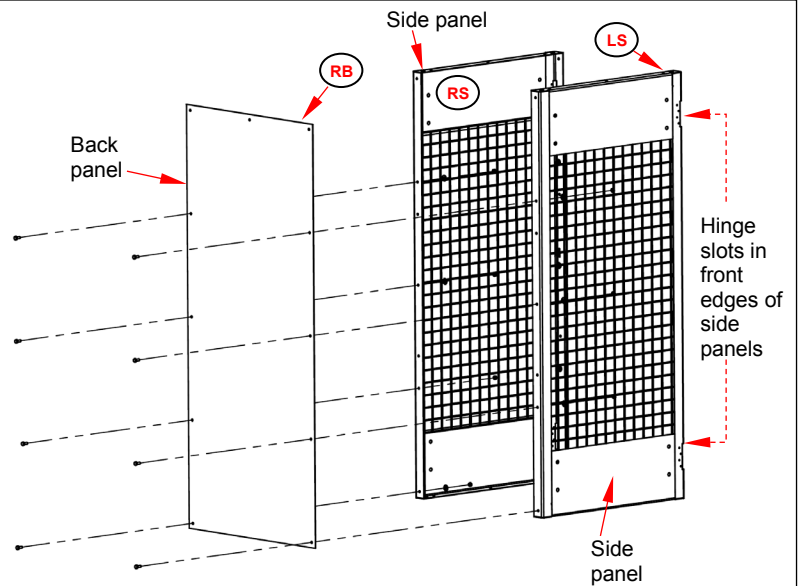

Step 2 – Attach the base plate (31-014-356) to the side panels

- Examine at the base plate. Notches are provided on two edges/sides. These are the front and rear edges of the base plate. The front and rear edges are identical.
- Set the base plate inside the assembly and align the large bolt holes in the plate with the bolt holes in the flange of the side panels.
- Push the two cabinets together in the location where they will be used. Fasten the 2 inner panels of the cabinets together with $\frac{1}{2}$ " hardware as shown.
- Anchor the cabinets to the ground. Mark the ground/surface with the locations of all 8 bolt holes (4 bolt holes per cabinet). The bolt holes will accept $\frac{1}{4}$ in. (diameter) anchor bolts. Your building engineer should determine how long the bolts should be.

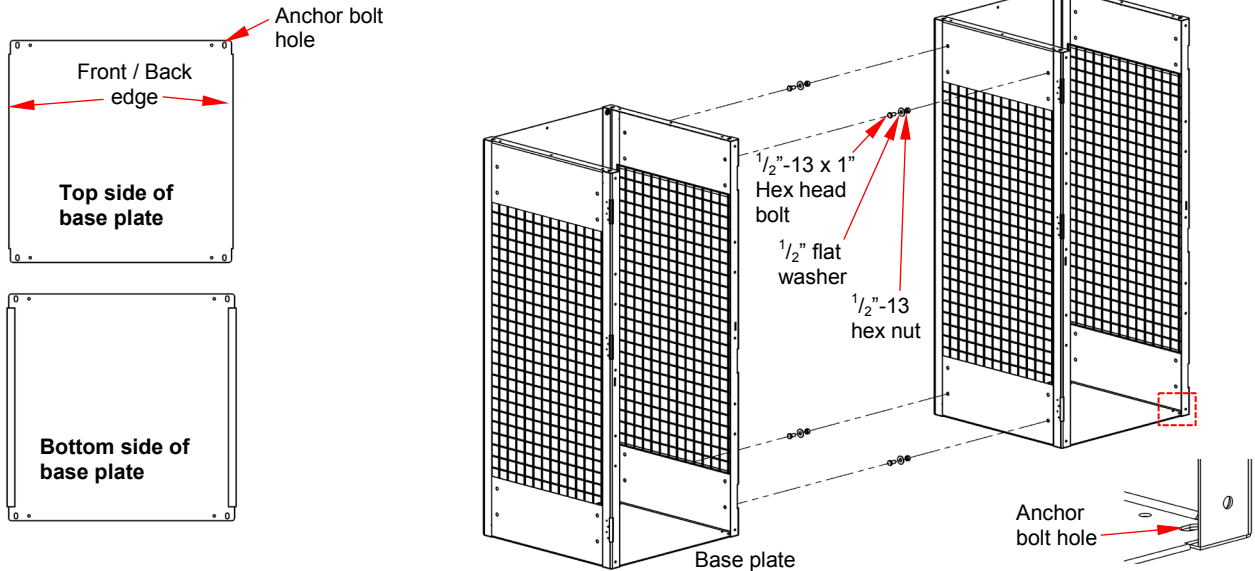

Step 3 – Attach the shelves

- The shelves are identical and can be installed interchangeably in any of the 4 possible locations.
- Remove the $\frac{5}{16}$ in. hex nuts (36104) and flat washers (33006) from the bolts connecting the side panels to the back panel.
- Install a shelf in the lowest position first. Insert the shelf into the assembly with cross supports pointing upwards. Align the bolt holes in the shelf frame with the bolts in the lowest bolt holes of the back panel and the side panels.
- Reinstall the flat washers and hex nuts. Tighten the nuts.
- Insert bolts through the lower bolt holes in the front sides of the side panels.
- Install the other shelves in the same manner.

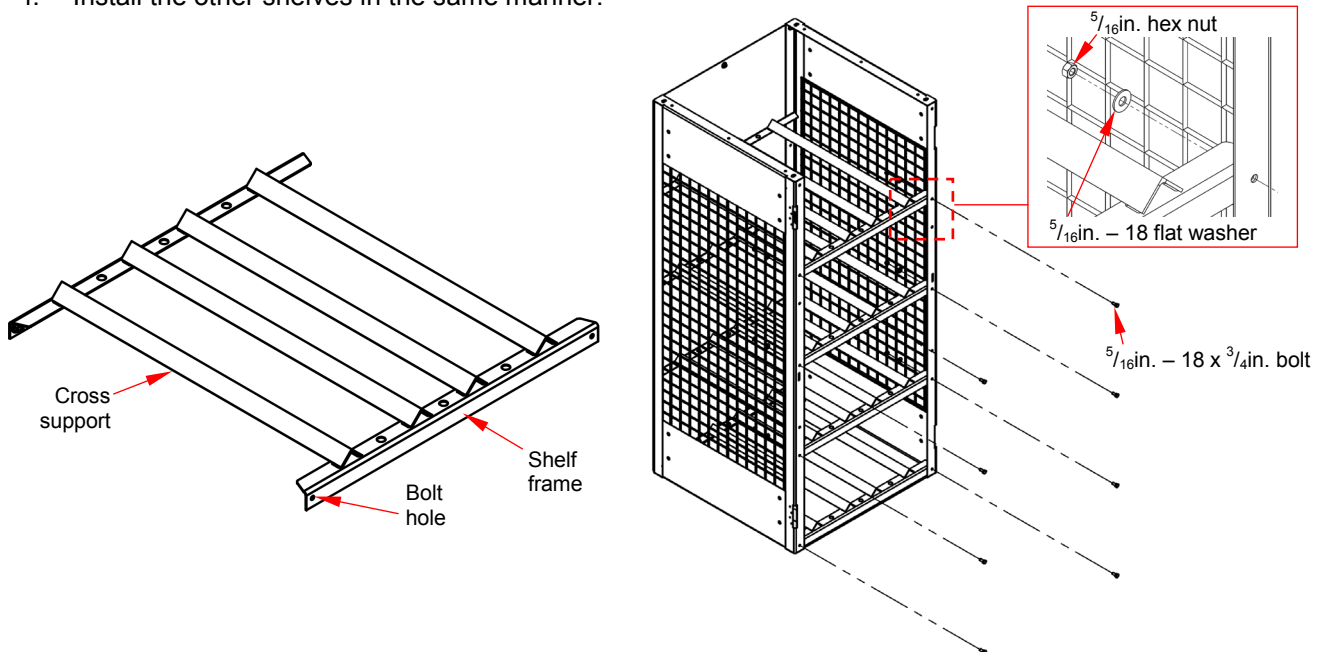

Step 4 – Attach door latch (31-037-001)

NOTE: If you want the doors of the 2 cabinets to open from the center (in opposite directions), then the door latches must be installed in adjacent sides.

- Each cabinet can be configured to allow the door to open to either the left or the right. Install latches in slots: 1) A & D for both doors to open toward the center of the cabinet; 2) A & C for both doors to open to the right; 3) B & C for the doors to open from the center; or 4) B & D for both to open to the left.
- Insert the latch through the latch slot from the inside of the cabinet.
- Insert the spring pin (64133) through the pin hole in

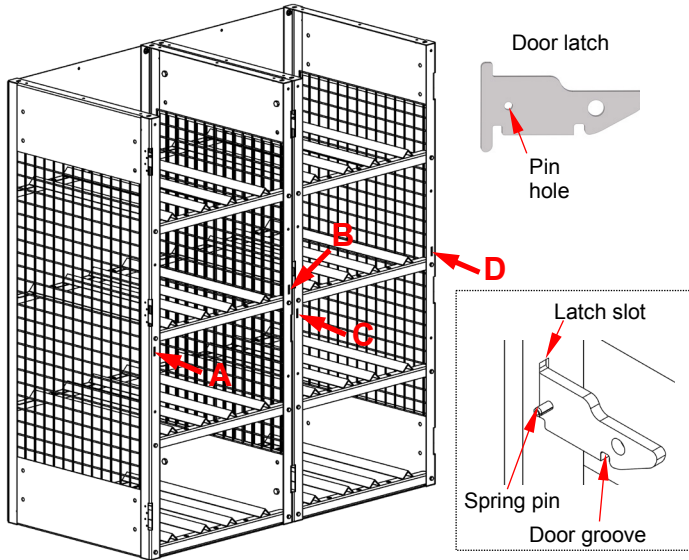

Step 5 – Attach top cap (31-014-357) to assembly

- Set the top cap on top of the assembly with the flanges overhanging the front and back sides.
- Fasten the top cap to the assembly with 12 sets of $\frac{5}{16}$ in. bolts, hex nuts, and flat washers as shown in the diagram.

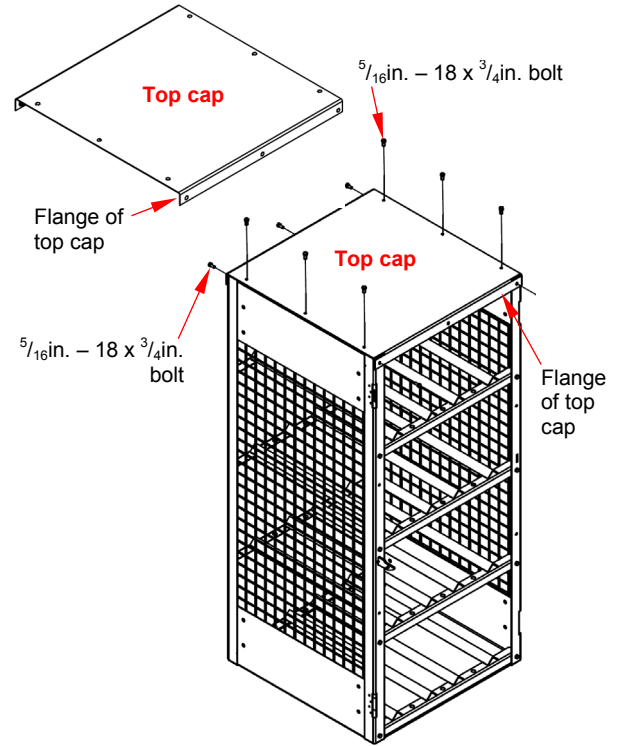

Step 6 – Attach hinges (31-012-002) to the side opposite the latch.

- Next to each hinge slot there are 4 holes. These holes are for the cap screws (24213). These screws attach the hinges to the side panels.
- Align the hinges with the holes in the side panel opposite the door latch. In the diagrams, the latch is on the left side, so the hinges are shown being attached to the right side.
- Fasten the hinges to the side panel with flat head socket cap screws (24213) and 10-32 hex nuts (36030).

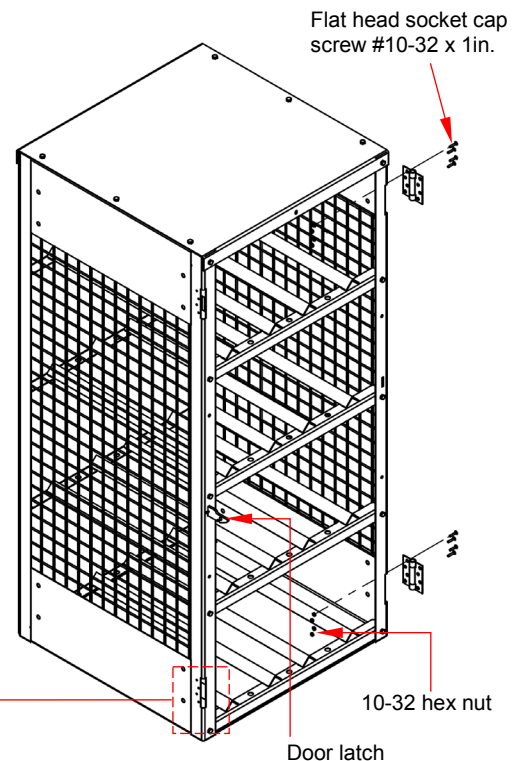
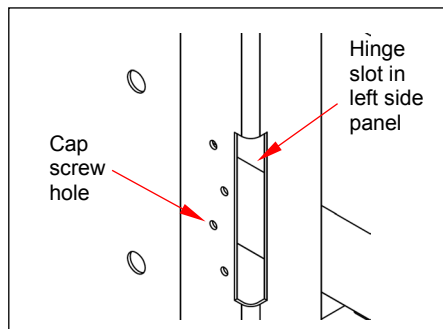

Step 7 – Attach door (7) to hinges

- Align the free sides of the hinges with the hinge holes in the door.
- Fasten the hinges to the door with flat head socket cap screws (#10-32 x 1in.) and 10-32 hex nuts.
- Close the door and confirm that the latch fits through the latch opening in the door. The door should seat into the door groove of the latch. See [Step 4](#) on p. 6.
- The door can be locked by attaching a padlock to the opening in the end of the latch.

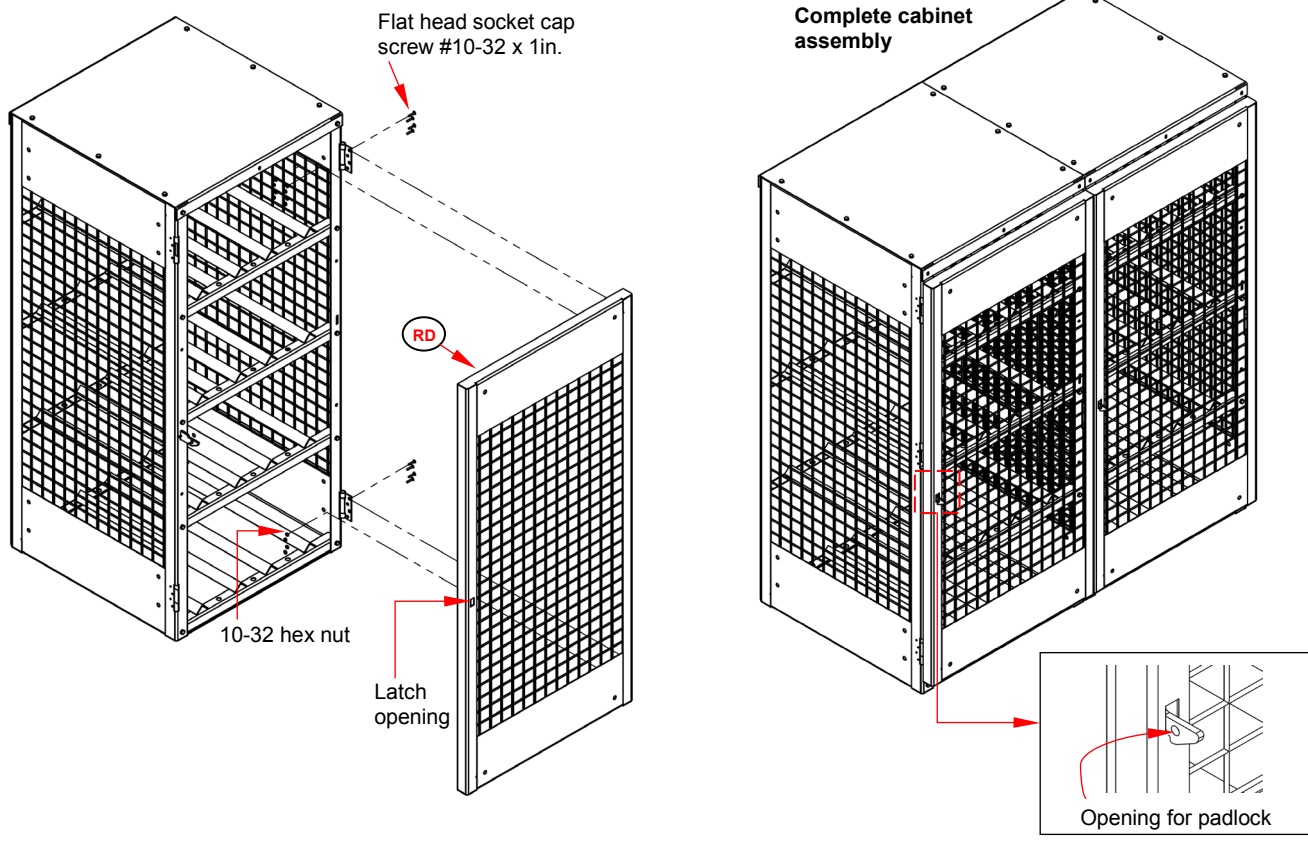

LOADING THE CABINET

Each shelf will accommodate 2 cylinders stored horizontally.

RECORD OF SATISFACTORY CONDITION

Before putting the cabinet into service, record its condition. Thoroughly photograph the unit from multiple angles. Take close range photographs of all labeling and fasteners (bolts, nuts, etc.). Photograph the entire perimeter of the base of the unit where it contacts the ground. Include photographs of the latch mechanism and the shelves. Collect all photographs in a single file and label the file appropriately to identify it. This file documents satisfactory condition. Compare the results of all inspections to this record to determine whether the cabinet is in satisfactory condition. Purely cosmetic changes, like damaged paint/powdercoat, do not constitute changes from satisfactory condition. However, touchup paint should be applied to all affected areas as soon as cosmetic damage occurs.

INSPECTIONS & MAINTENANCE

Compare the results of each inspection to the [Record](#) to determine whether the cabinet is in satisfactory condition. If repairs/replacement parts are necessary, restore the cabinet to satisfactory condition BEFORE returning it to service.

- Apply grease to the hinges whenever necessary, e.g. squeaky or noisy operation.
- Inspect the cabinet at least once per month. Check for corrosion and rust especially where paint is damaged:
 - Remove rust with a steel bristle brush (or sandpaper) and apply touchup paint or clear finish to the affected area;
 - Inspect the base of the cabinet in contact with the ground:

- Remove rust and reseal if necessary;
- Check for deformation, for example bending, warping, or cracking;
- iii) Inspect the cylinder supports:
 - Remove rust and reseal if necessary;
 - Check for deformation (bending, warping, or cracking).
- iv) Inspect the labeling. Replace labels that are damaged, missing, or not easily readable.

LABELING DIAGRAM

The unit should be labeled as shown in the diagrams. However, label content and location are subject to change so your product might not be labeled exactly as shown. Thoroughly photograph the unit when you first receive it as discussed in the *Record of Satisfactory Condition* portion of the *Inspections and Maintenance* section on p. 7-8. Make sure that your record includes a photograph of each label. Replace all labels that are, or later become, damaged, missing, or not easily readable (e.g. faded). To order replacement labels, contact the technical service and parts department online at http://www.vestilmfg.com/parts_info.htm. Alternatively, you may request replacement parts and/or service by calling (260) 665-7586 and asking the operator to connect you to the *Parts Department*.

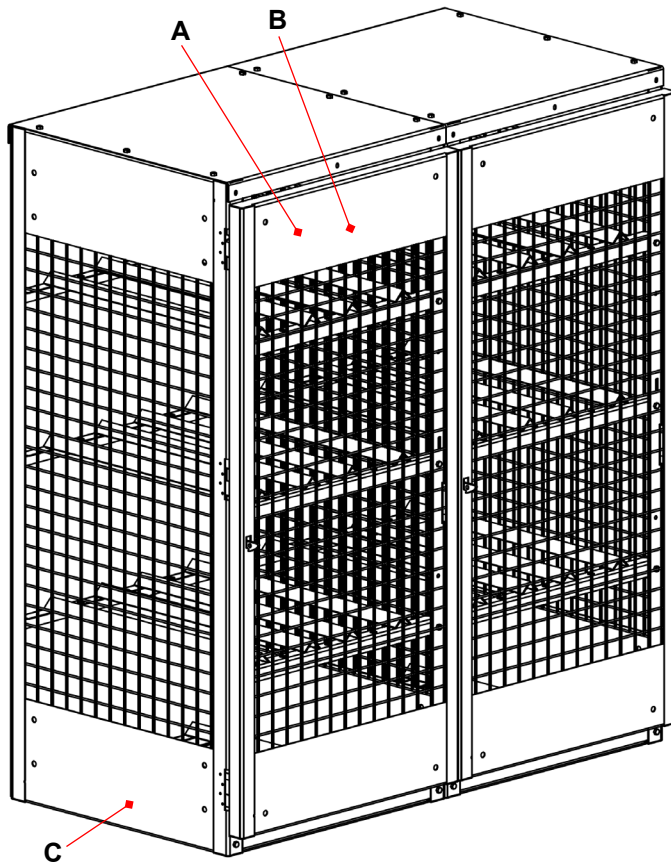

A: All units

Label 287: Model & capacity
(Applied to inside of door)

MODEL/MODÉLO/MODÈLE _____	
STATIC CAPACITY (evenly distributed) _____	lbs.
LA CAPACIDAD CONSTANTE (distribuida uniformemente) _____	kgs.
CAPACITÉ STATIQUE (distribuée régulièrement) _____	kgs.
SERIAL/SERIE/SÉRIE _____	

287 REV 0812

B: Units used within USA

Label 735: FLAMMABLE – NO SMOKING
(Applied to fronts of both doors)



Units used in Canada

Both Label 735 (above) & Label 736 (below):
(Applied to fronts of both doors)



C: Label 204: Secure frame to floor
(Apply to each side panel of each cabinet)

▲ WARNING	▲ ADVERTENCIA	▲ AVERTISSEMENT
SECURE FRAME TO FLOOR	ASEGURE EL BASTIDOR AL PISO	FIXER SOLIDEMENT LE CADRE AU PLANCHER

204 Rev 1116

LIMITED WARRANTY

Vestil Manufacturing Corporation (“Vestil”) warrants this product to be free of defects in material and workmanship during the warranty period. Our warranty obligation is to provide a replacement for a defective, original part covered by the warranty after we receive a proper request from the Warrantee (you) for warranty service.

Who may request service?

Only a warrantee may request service. You are a warrantee if you purchased the product from Vestil or from an authorized distributor AND Vestil has been fully paid.

Definition of “original part”?

An original part is a part used to make the product as shipped to the Warrantee.

What is a “proper request”?

A request for warranty service is proper if Vestil receives: 1) a photocopy of the Customer Invoice that displays the shipping date; AND 2) a written request for warranty service including your name and phone number. Send requests by one of the following methods:

<u>US Mail</u>	<u>Fax</u>	<u>Email</u>
Vestil Manufacturing Corporation 2999 North Wayne Street, PO Box 507 Angola, IN 46703	(260) 665-1339 <u>Phone</u> (260) 665-7586	info@vestil.com Enter “Warranty service request” in subject field.

In the written request, list the parts believed to be defective and include the address where replacements should be delivered. After Vestil receives your request for warranty service, an authorized representative will contact you to determine whether your claim is covered by the warranty. Before providing warranty service, Vestil will require you to send the entire product, or just the defective part (or parts), to its facility in Angola, IN.

What is covered under the warranty?

The warranty covers defects in the following original, dynamic parts: motors, hydraulic pumps, motor controllers, and cylinders. It also covers defects in original parts that wear under normal usage conditions (“wearing parts”), such as bearings, hoses, wheels, seals, brushes, and batteries.

How long is the warranty period?

The warranty period for original dynamic components is 90 days. For wearing parts, the warranty period is 90 days. Both warranty periods begin on the date Vestil ships the product to the Warrantee. If the product was purchased from an authorized distributor, the periods begin when the distributor ships the product. Vestil may, at its sole discretion, extend a warranty period for products shipped from authorized distributors by up to 30 days to account for shipping time.

If a defective part is covered by the warranty, what will Vestil do to correct the problem?

Vestil will provide an appropriate replacement for any *covered* part. An authorized representative of Vestil will contact you to discuss your claim.

What is not covered by the warranty?

The Warrantee (you) is responsible for paying labor costs and freight costs to return the product to Vestil for warranty service.

Events that automatically void this Limited Warranty.

- Misuse;
- Negligent assembly, installation, operation or repair;
- Installation/use in corrosive environments;
- Inadequate or improper maintenance;
- Damage sustained during shipping;
- Collisions or other accidents that damage the product;
- Unauthorized modifications: Do not modify the product IN ANY WAY without first receiving written authorization from Vestil.

Do any other warranties apply to the product?

Vestil Manufacturing Corp. makes no other express warranties. All implied warranties are disclaimed to the extent allowed by law. Any implied warranty not disclaimed is limited in scope to the terms of this Limited Warranty. Vestil makes no warranty or representation that this product complies with any state or local design, performance, or safety code or standard. Noncompliance with any such code or standard is not a defect in material or workmanship.

