



Vestil Manufacturing Corp.
 2999 North Wayne Street, P.O. Box 507, Angola, IN 46703
 Telephone: (260) 665-7586 -or- Toll Free (800) 348-0868
 Fax: (260) 665-1339
 Web: www.vestilmfg.com e-mail: info@vestil.com

ETS-840-30 Self-Adjusting Work Tables Instruction Manual



Receiving instructions:

After delivery, remove the packaging from the product. Inspect the product closely to determine whether it sustained damage during transport. If damage is discovered, record a complete description of it on the bill of lading. If the product is undamaged, discard the packaging.

NOTE: The end-user is solely responsible for confirming that product design, use, and maintenance comply with laws, regulations, codes, and mandatory standards applied where the product is used.

Replacement Parts and Technical Assistance:

For answers to questions not addressed in these instructions and to order replacement parts, labels, and accessories, call our Technical Service and Parts Department at (260) 665-7586. The department can also be contacted online at http://www.vestilmfg.com/parts_info.htm.

Table of Contents

Specifications.....	2
Signal Words.....	2
Hazards.....	2 – 3
Exploded View and Bill of Materials: ETS-840-30 & ETS-1120-24.....	3
Using the Table.....	4
Record of Normal Condition.....	4
Inspections & Maintenance.....	5
Labeling Diagram.....	5
Limited Warranty.....	6

Specifications:

Dimensions, capacity, and net weight information appear in the table and diagrams.

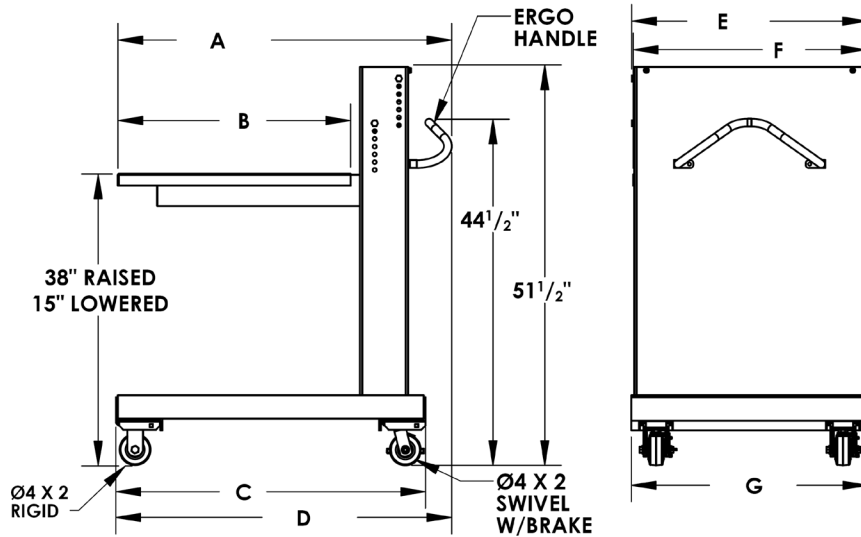

Model	Capacity	Net weight
ETS-840-30	840 lb. 381.8 kg	310lb. 140.9 kg
ETS-1120-24	1120 lb. 509.1 kg	268 lb. 121.8 kg

Model	A	B	C	D	E	F	G
ETS-840-30	43 ¹ / ₁₆ " 109.4cm	30" 76.2cm	40" 101.6cm	43 ⁵ / ₁₆ " 110.0cm	30 ³ / ₈ " 77.2cm	30" 76.2cm	30 ¹ / ₂ " 77.5cm
ETS-1120-24	37 ⁷ / ₁₆ " 95.1cm	24" 61.0cm	34" 86.4cm	37 ⁵ / ₁₆ " 94.8cm	24 ³ / ₈ " 61.9cm	24" 61.0cm	24 ¹ / ₂ " 62.2cm

Signal Words:

This manual uses SIGNAL WORDS to indicate the likelihood that a particular action will cause personal injuries or property damage. Signal words also specify the level of seriousness of injury if the product is misused in the ways described. The following signal words are used in this manual.

- ⚠ DANGER** Identifies a hazardous situation which, if not avoided, WILL result in DEATH or SERIOUS INJURY. Use of this signal word is limited to the most extreme situations.
- ⚠ WARNING** Identifies a hazardous situation which, if not avoided, COULD result in DEATH or SERIOUS INJURY.
- ⚠ CAUTION** Identifies practices likely to result in product/property damage, such as operation that might damage the product.
- NOTICE** Identifies practices likely to result in product/property damage, such as operation that might damage the ladder.

Hazards:

Vestil strives to identify all hazards associated with the use of its products. However, material handling is dangerous and no manual can address every risk. The most effective means for preventing accidents is for the end-user to exercise common sense and sound judgment whenever using this product.

- ⚠ WARNING** Improper or careless use might result in serious personal injuries.
 - Do not remove, alter, or obscure any label. If a label is damaged or unreadable, replace it. DO NOT use the lifter until all replacement labels are applied.
 - Do not exceed the capacity of your table! Each table is labeled with its capacity. See Label 287 in [Labeling Diagram](#) on p. 5.
 - The table should never be used with fewer than 4 springs.
 - Center and evenly distribute loads applied to the table.
 - Apply both caster brakes whenever the table is stationary and particularly whenever loads are applied.
 - Do not move the table across sloped terrain while it is loaded.
 - ALWAYS remain uphill of the (unloaded) table whenever moving up or down inclines. If you cannot easily handle the table, do not attempt to move it by yourself.
 - Keep your hands away from pinch points and openings. Do not reach beneath the table while it is loaded.

WARNING (continued from p. 2)

- [Referring to [Using the table, Step 3\(e-h\), p.4](#)] The upper and lower hanger rod brackets **MUST** be connected to the same numbered bolts holes. If the lower hanger bracket is connected to a higher numbered bolt hole, excess spring tension is applied to both hangers. Injury could occur when deck height is adjusted later. If the lower hanger rod is connected to lower numbered bolt holes, the deck is able to move up and down and could cause the deck to tip.
- Carefully load the table, i.e. do not drop loads onto it.
- Do not modify this table without express, written approval from Vestil. Unauthorized modifications automatically void the [Limited Warranty](#) on p. 6 and might make the table unsafe to use.
- Maintain the device according to the [Inspections & Maintenance](#) instructions on p. 5. If replacement parts are needed, only install manufacturer-approved parts.

Exploded View and Bill of Materials: ETS-840-30 & ETS-1120-24

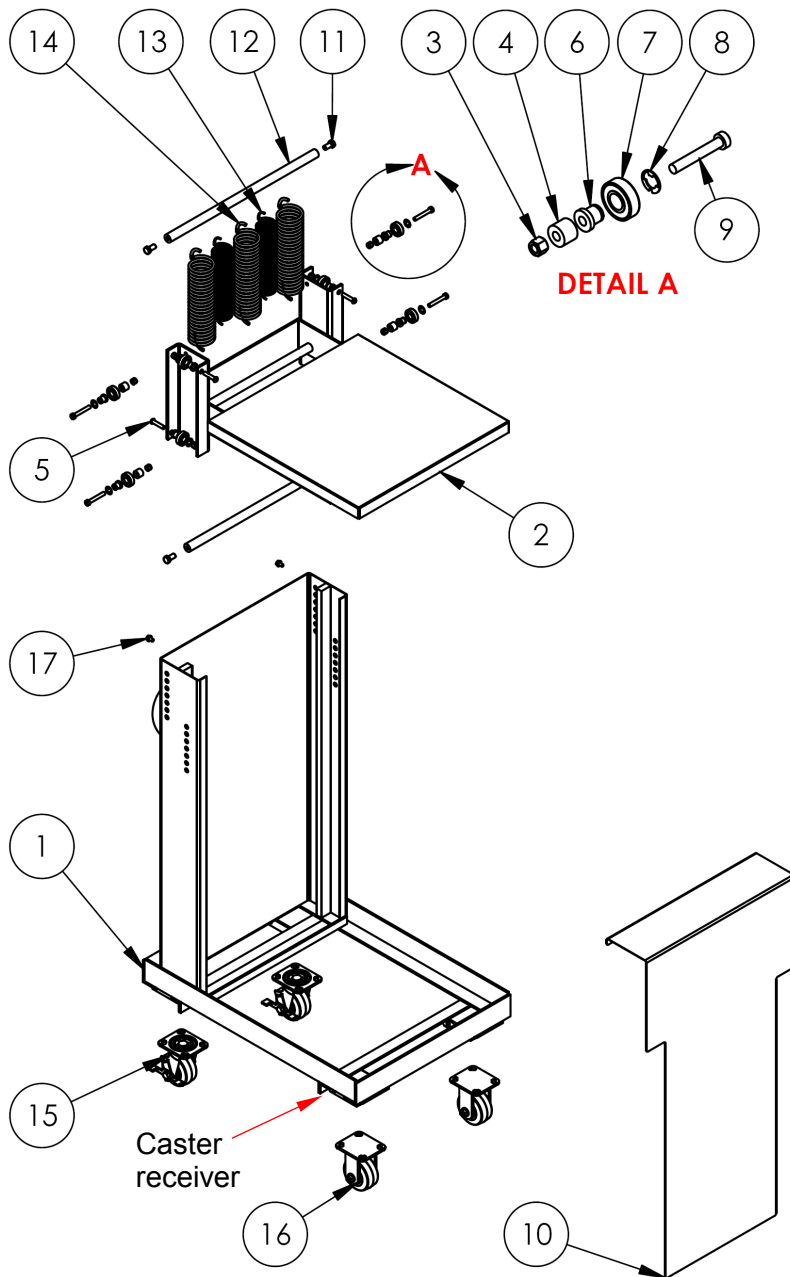

Item	Part no.	Description	Qty.
1	21-514-035	Weldment, body, S/A:	1
	21-514-037	ETS-840-30	1
2	21-538-021	Carriage S/A:	1
	21-538-023	ETS-840-30	1
3	37024	Nylon insert lock nut, gr. 2, z-finish, 3/8"-16	8
4	21-113-020	Spacer, bearing, formed	4
5	24095	Bolt, button head, BHSCS, 3/8"-16x1 3/4"	4
6	21-113-021	Spacer, bearing, shaft	8
7	20-110-006	Roller bearing	8
8	68083	E-clip, steel, fits 5/8" shaft	8
9	24718	Screw, button head, BHSCS, 3/8"-16x2 1/2"	4
10	21-024-008	Guard/cover, front, formed	1
11	11205	Hex bolt, gr. A, z-plated, 1/2"-12x1"	4
12	21-016-030	Bracket, hanger rod:	2
	21-016-032	ETS-840-24	
13	21-146-002	Spring, extension, #2	2
14	21-146-001	Spring, extension, #1	3
15	16-132-054	Caster, swivel	2
16	16-132-012	Caster, rigid	2
17	32415	Thread-cutting screw, type F, zinc plated, 5/16"-18x1 1/2"	2

Using the table:

NOTE: Numbers in parentheses () correspond to item numbers in the *Exploded View* on p. 3.

1. Position the table as needed.
2. Apply both caster brakes.
3. Adjust the height of the load deck to an ergonomically optimized setting. The deck is factory set to its maximum height. This means that the deck cannot be any higher, but it can be lowered. If the deck height is already optimal, then proceed to step 4.

Adjusting deck height requires 2 people. The deck can be set to any of 7 heights. If the deck needs to be adjusted:

- a. Remove the thread-cutting screws (17) that fasten the cover (10) to the mast.
 - b. Lift the cover off of the mast and set it aside.
 - c. One person must grasp the upper hanger rod bracket (12) while the other removes the upper hex head bolts (11) from both sides of the mast.
 - d. Move the upper rod bracket up or down until the deck is at the preferred height.
 - e. Align both ends of the upper hanger rod bracket with the closest adjustment hole on each side of the mast. The same bolt hole on each side must be aligned with the bracket (e.g. bolt hole 3 on both sides).
 - f. Reinstall the hex bolts (11).
 - g. Remove the lower hex bolts (11) from both sides of the mast.
 - h. Align the lower hanger rod bracket with the **same pair of holes [1-7]** that the upper bracket is connected to and reinstall the hex bolts. If the upper hanger bracket was lowered to hole 3 in steps e & f, then also attach the lower hanger bracket to hole 3.
 - i. Put the cover back on and reinstall the screws (17).
4. *Carefully* apply the load to the table. NEVER shock load the table, e.g. drop loads on the deck.

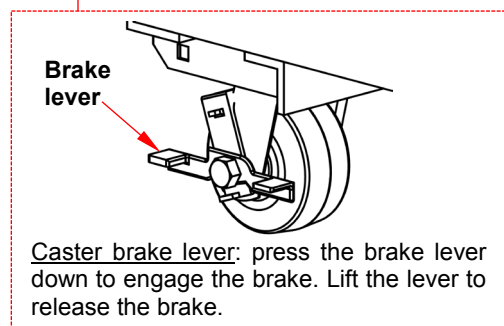
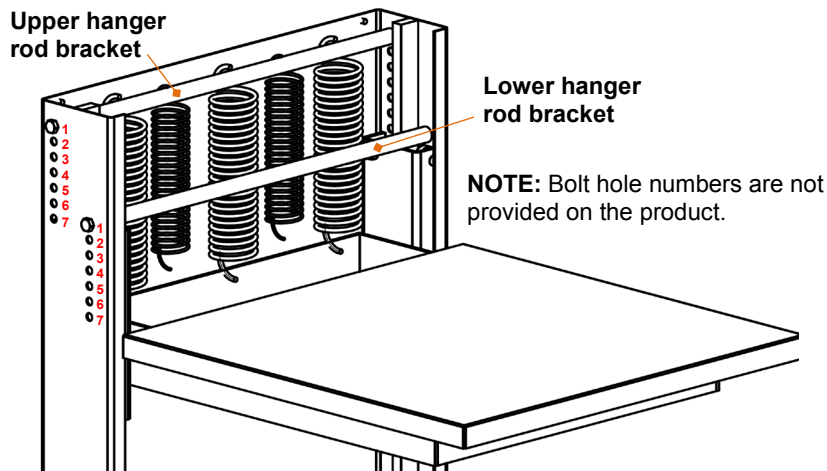
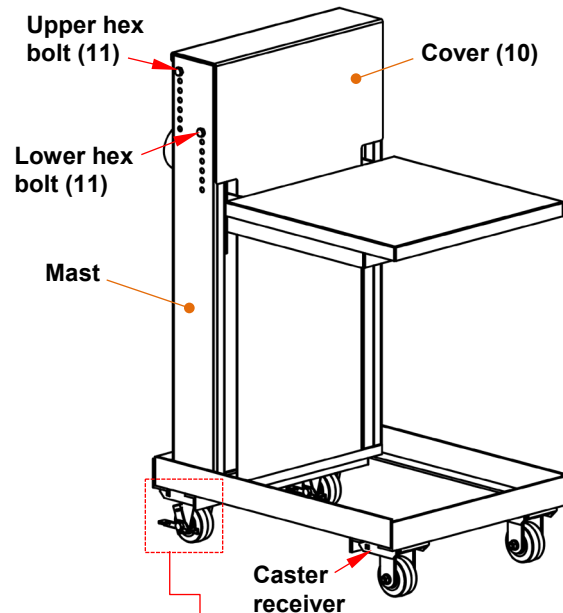
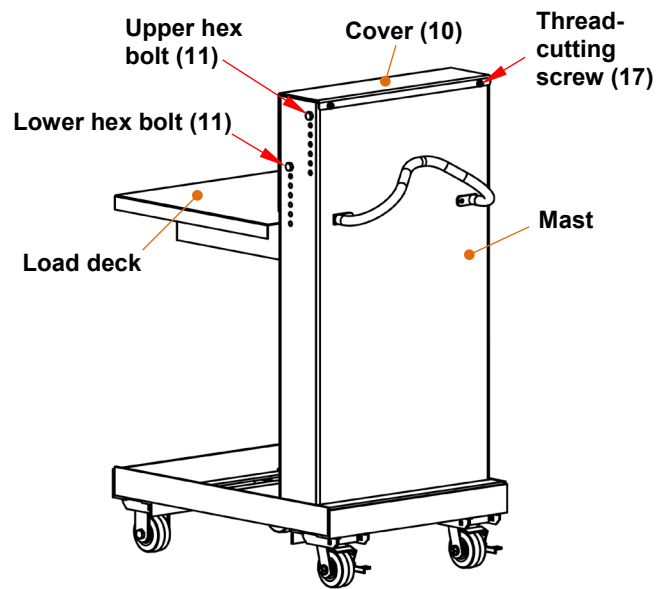

Record of Normal Condition:

Before using the table for the first time, create a written record of its appearance and functions. Include detailed descriptions about the frame, casters, load deck, and the mast. Include observations about how the load deck responds when a test weight is applied to it as well as any sounds you hear. Thoroughly photograph the unit and all labels. Remove the cover and photograph the deck height adjustment mechanisms (springs, hanger rods). Add the photographs to the record. This record establishes “**normal condition**”.

Inspections & Maintenance:

Regular inspections and maintenance are necessary to keep the table in normal condition for as long as possible. Compare your observations with the [Record of Normal Condition](#) to determine if the table is in normal condition or requires repair or replacement. Do not use the table unless it is in normal condition. Complete all replacements and repairs before returning the table to service. Purely cosmetic changes that do not affect normal operation of the table are not changes from normal condition. However, regions where the paint/powder coat is damaged should immediately be cleaned and repaired with touchup paint.

Step 1: Tag the table “Out of Service.”

Step 2: At least once per month, inspect the elements listed below. Refer to the appropriate [Exploded View](#) on p. 3.

- A. **Frame:** Inspect all welds for cracks. Inspect the metal tubing for damage, warps, and cracks. Also examine the connection points between the frame and the formed base piece. Make sure that the nuts and bolts are securely fastened together and that the bolt holes in the frame are not elongated, warped, or cracked.
- B. **Casters, caster receivers, and retaining hardware:** Check casters for excessive wear. All 4 casters should solidly contact the ground and should roll smoothly without wobbling. Examine the center hub of each caster for cracks. Confirm that caster receivers (see p. 3 or 4) and retaining hardware are in normal condition.
- C. **Mast, load deck, and frame:** Inspect for cracks, bends, and other damage. The deck should be level, square, and rigid. Apply a test load to the deck. The deck should maintain position under load.
- D. **Springs, upper and lower hanger rod brackets, and hardware:** Remove the cover. The process for removing the cover is provided in [Using the table, Step 3, p. 4](#). Examine the springs. Confirm that every spring is intact. Replace a spring if it is stretched, bent, broken, or severely rusted. Inspect the rod brackets for bends, cracks, etc. Examine the hex bolts for bends, warps, cracks, etc.

Step 3: Complete all necessary repairs and replacements. Deformities, severe corrosion or rusting, or excessive wear of any part warrants immediate replacement of that part. DO NOT return the table to service until adjustments and repairs are complete! If you are uncertain whether the table should remain in service, contact [Technical Service](#).

NOTE: Adjustments and repairs differ significantly from modifications.

- a) **Adjustment (or repair)** means a simple correction that restores the table to normal condition. Examples include tightening loose fasteners and lubricating moving parts.
- b) **Modifications** are changes that alter the table from original condition, like bending the frame. NEVER modify the cart without express, written approval from Vestil. Modifications automatically void the limited warranty and might make the device unsafe to use.

Step 4: Make a dated record of all repairs, adjustments and replacements.

Step 5: Store the table indoors in a dry location.

Labeling Diagram:

Each unit should be labeled as shown in the diagram. However, label content and location are subject to change without notice so your product might not be labeled exactly as shown. Replace all labels that are damaged, missing, or not easily readable (e.g. faded). To order replacement labels, contact [Technical Service](#) online at http://www.vestilmfg.com/parts_info.htm. Alternatively, you may request replacement parts and/or service by calling (260) 665-7586 and asking the operator to connect you with Technical Service.

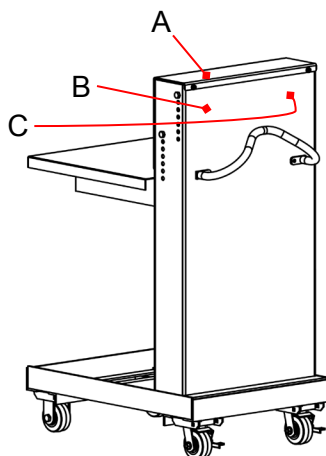

A: Label 287

MODEL/MODELO/MODELE	
STATIC CAPACITY (evenly distributed)	_____ lbs.
LA CAPACIDAD CONSTANTE (distribuida uniformemente)	_____ kgs.
CAPACITÉ STATIQUE (distribuée régulièrement)	_____ kgs.
SERIAL/SERIE/SÉRIE	_____
287 REV 0812	

B: Label 658

⚠ WARNING	⚠ ADVERTENCIA	⚠ AVERTISSEMENT
Do not operate or move with unstable loads DO NOT LOAD beyond rated capacity DISTRIBUTE LOAD EVENLY DO NOT sit or ride	No use a mueva con cargas inestables No cargue más de la capacidad tasada DISTRIBUYA LA CARGA A NIVEL NO SE SIENTE o vaya en el carro	Ne pas utiliser avec une charge instable NE PAS CHARGER au-delà du débit nominale DISTRIBUER la charge régulièrement NE PAS VOUS ASSEoir OU VOUS PROMENER sur le chariot
658 REV 0609		

C: Label 212

⚠ WARNING	⚠ ADVERTENCIA	⚠ AVERTISSEMENT
LOCK CASTER and/or FLOOR LOCK when loading and unloading	La RUEDECILLA de la CERRADURA y/o el PISO CIERRAN al cargar y descargar	LOCK CASTER et/ou SOL LOCK lors du chargement et de déchargement
212 Rev 0111		

LIMITED WARRANTY

Vestil Manufacturing Corporation (“Vestil”) warrants this product to be free of defects in material and workmanship during the warranty period. Our warranty obligation is to provide a replacement for a defective, original part covered by the warranty after we receive a proper request from the Warrantee (you) for warranty service.

Who may request service?

Only a warrantee may request service. You are a warrantee if you purchased the product from Vestil or from an authorized distributor AND Vestil has been fully paid.

Definition of “original part”?

An original part is a part used to make the product as shipped to the Warrantee.

What is a “proper request”?

A request for warranty service is proper if Vestil receives: 1) a photocopy of the Customer Invoice that displays the shipping date; AND 2) a written request for warranty service including your name and phone number. Send requests by one of the following methods:

<u>US Mail</u>	<u>Fax</u>	<u>Email</u>
Vestil Manufacturing Corporation 2999 North Wayne Street, PO Box 507 Angola, IN 46703	(260) 665-1339 <u>Phone</u> (260) 665-7586	info@vestil.com Enter “Warranty service request” in subject field.

In the written request, list the parts believed to be defective and include the address where replacements should be delivered. After Vestil receives your request for warranty service, an authorized representative will contact you to determine whether your claim is covered by the warranty. Before providing warranty service, Vestil will require you to send the entire product, or just the defective part (or parts), to its facility in Angola, IN.

What is covered under the warranty?

The warranty covers defects in the following original, dynamic parts: motors, hydraulic pumps, motor controllers, and cylinders. It also covers defects in original parts that wear under normal usage conditions (“wearing parts”), such as bearings, hoses, wheels, seals, brushes, and batteries.

How long is the warranty period?

The warranty period for original dynamic components is 1 year. For wearing parts, the warranty period is 90 days. Both warranty periods begin on the date Vestil ships the product to the Warrantee. If the product was purchased from an authorized distributor, the periods begin when the distributor ships the product. Vestil may, at its sole discretion, extend a warranty period for products shipped from authorized distributors by up to 30 days to account for shipping time.

If a defective part is covered by the warranty, what will Vestil do to correct the problem?

Vestil will provide an appropriate replacement for any *covered* part. An authorized representative of Vestil will contact you to discuss your claim.

What is not covered by the warranty?

The Warrantee (you) is responsible for paying labor costs and freight costs to return the product to Vestil for warranty service.

Events that automatically void this Limited Warranty.

- Misuse;
- Negligent assembly, installation, operation or repair;
- Installation/use in corrosive environments;
- Inadequate or improper maintenance;
- Damage sustained during shipping;
- Collisions or other accidents that damage the product;
- Unauthorized modifications: Do not modify the product IN ANY WAY without first receiving written authorization from Vestil.

Do any other warranties apply to the product?

Vestil Manufacturing Corp. makes no other express warranties. All implied warranties are disclaimed to the extent allowed by law. Any implied warranty not disclaimed is limited in scope to the terms of this Limited Warranty. Vestil makes no warranty or representation that this product complies with any state or local design, performance, or safety code or standard. Noncompliance with any such code or standard is not a defect.

