



Vestil Manufacturing Company

2999 North Wayne Street, P.O. Box 507, Angola, IN 46703

Telephone: (260) 665-7586 -or- Toll Free (800) 348-0868

Fax: (260) 665-1339

Web: www.vestil.com e-mail: info@vestil.com

IBC-TLT



Receiving Instructions

After delivery, remove the packaging from the product. Inspect the product closely to determine whether it sustained damage during transport. If damage is discovered, record a complete description of it on the bill of lading. If the product is undamaged, discard the packaging.

NOTE: The end-user is solely responsible for confirming that product design, use, and maintenance comply with laws, regulations, codes, and mandatory standards applied where the product is used.

Technical Service & Replacement Parts

For answers to questions not addressed in these instructions and to order replacement parts, labels, and accessories, call our Technical Service and Parts Department at (260) 665-7586. The Department can also be contacted online at <https://www.vestil.com/page-parts-request.php>.

Electronic Copies of Instruction Manuals

Additional copies of this instruction manual may be downloaded from <https://www.vestil.com/page-manuals.php>.

Table of Contents

	Page
Signal Words.....	2
Safety Instructions.....	2
Exploded View and Bill of Materials.....	3
Attaching the Casters.....	4
Using the Container Cart.....	4
Record of Satisfactory Condition.....	5
Inspections & Maintenance.....	5
Labeling Diagram.....	6
Limited Warranty.....	7

SIGNAL WORDS

SIGNAL WORDS appear in this manual to draw the reader’s attention to important safety-related messages. The following are signal words used in this manual and their definitions.

⚠ DANGER	Identifies a hazardous situation which, if not avoided, <u>WILL</u> result in DEATH or SERIOUS INJURY. Use of this signal word is limited to the most extreme situations.
⚠ WARNING	Identifies a hazardous situation which, if not avoided, COULD result in DEATH or SERIOUS INJURY.
⚠ CAUTION	Indicates a hazardous situation which, if not avoided, COULD result in MINOR or MODERATE injury.
NOTICE	Identifies practices likely to result in product/property damage, such as operation that might damage the product.

SAFETY INSTRUCTIONS

Vestil strives to identify all foreseeable hazards associated with the use of its products. However, material handling is dangerous and no manual can address every conceivable risk. Ultimately, the most effective way to prevent injury is to apply sound judgment whenever using this device.

⚠ WARNING

Risk of death or serious personal injuries.

- *Read and understand the entire manual before assembling, installing, using or servicing the product.* Read the manual to refresh your understanding of proper use and maintenance procedures. A copy of this manual should be available to all persons who use the cart.
- DO NOT attempt to resolve any problem(s) with the product unless you are both authorized to do so and certain that it will be safe to use afterwards.
- DO NOT modify the product in any way UNLESS you first obtain written approval from Vestil. Unapproved modifications automatically void the **LIMITED WARRANTY** on p. 7 and might make the product unsafe to use.
- DO NOT exceed the capacity: 4,400 pounds (2,000kg). Capacity information is provided in on-product labeling. See Label 1153 in the **LABELING DIAGRAM** on p. 6.
- Inspect the product according to the instructions in **INSPECTIONS & MAINTENANCE** on p. 5 DO NOT use the product unless it is in *satisfactory condition*.
- DO NOT use the cart on sloped ground. Only use it on even, level ground.
- DO NOT use the cart UNLESS all labels are readable & undamaged. See **LABELING DIAGRAM**.

EXPLODED VIEW AND BILL OF MATERIALS (16-006-411)

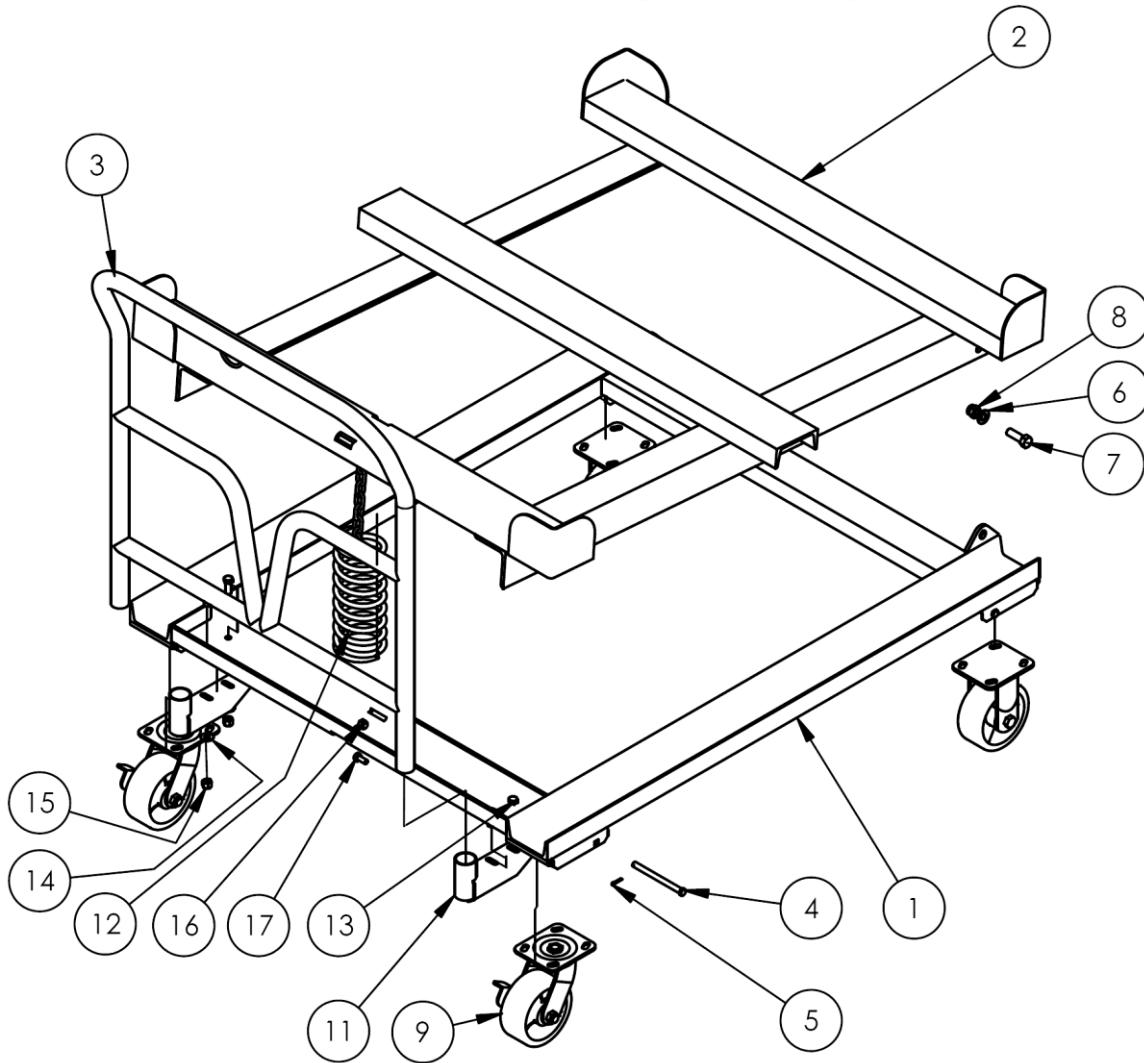

ITEM NO.	PART NO	DESCRIPTION	QTY.
1	16-514-278	WELDMENT,LOWER FRAME	1
2	16-514-277	WELDMENT,UPPER FRAME (CONTAINER SUPPORT)	1
3	16-025-031	HANDLE, CHROMED, PUSH CARTS	1
4	99-112-006	PIN, CLEVIS	4
5	65073	COTTER PIN, ZINC FINISH, Ø1/8 X 5/8"	4
6	33011	FLAT WASHER, USS, PLAIN FINISH, Ø1/2"	2
7	11209	1/2-13 X 1 1/2" LG HHCS - ASTM A307, GRADE A, ZINC PLATED	2
8	37030	1/2"-13 NYLON INSERT LOCK NUT	2
9	16-132-053	PU-5/2-S-SWB, SWIVEL CASTER W/BRAKE	2
10	16-132-022	PU-5/2-R, RIGID CASTER	2
11	16-016-063	BRACKET, HANDLE	2
12	16-146-005	SPRING,TILTING SPRING	1
13	11105	HEX BOLT, GRADE A, ZINC PLATED, 3/8"-16 X 1"	4
14	33006	FLAT WASHER,ZINC PLATED,USS, Ø5/16"	4
15	37024	NYLON INSERT LOCK NUT, GRADE 2, ZINC FINISH, 3/8"-16	4
16	37021	NYLON INSERT LOCK NUT, GRADE 2, ZINC FINISH, 5/16"-18	1
17	11053	Ø 5/16 - 18 x 3/4 LG, HHCS #2 ZINC PLATED	1

ATTACHING THE CASTERS

Numbers in parentheses correspond to part numbers in the bills of materials on p. 3.

Attach casters to the underside of the lower frame subassembly (16-514-278). There are 2 types of caster included in the hardware kit: 1) Rigid casters (16-132-022); and 2) Swiveling casters with brakes (16-132-053). The diagram below and [EXPLODED VIEW](#) indicate where each caster must be installed. Place the mounting plate of each caster inside a bulldog caster receiver. Secure the casters in place with a clevis pin (99-112-006) and cotter pin (65073).

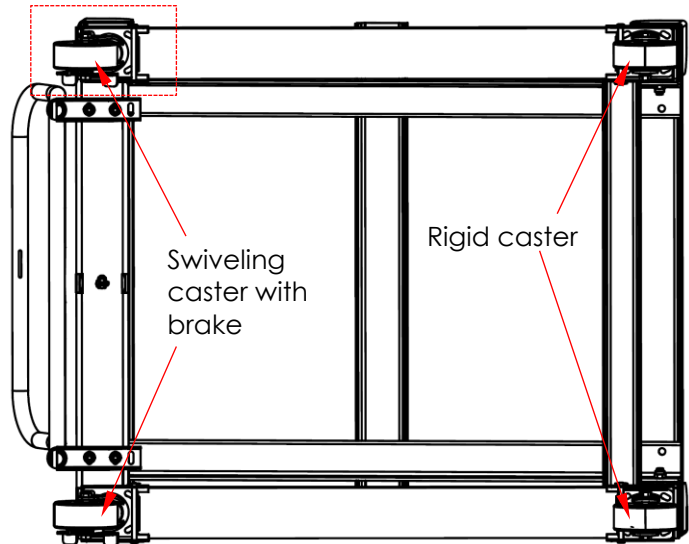
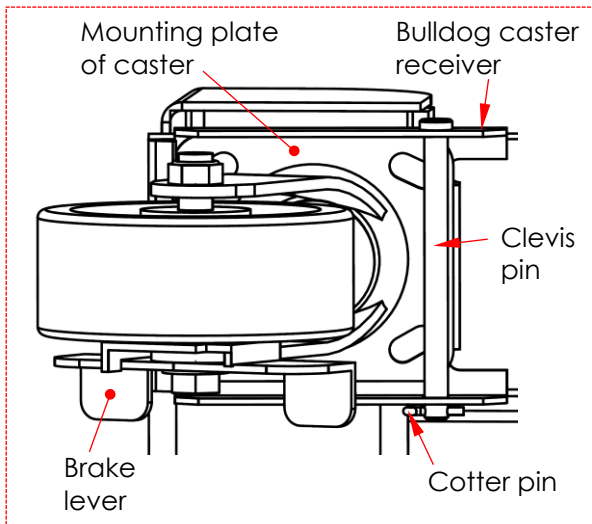

USING THE CONTAINER CART

Install the legs of the handle in the handle brackets (16-016-063). The cart is designed to support 275gal or 300 gal. intermediate bulk containers (ICB). Place an ICB on the cart with the drain valve opposite the spring. Make sure that the container fits inside the 4 retainers. The spring elevates the back side of the container support as the weight of the container decreases. Elevating the back side of the ICB causes its contents to flow towards the drain. Lock both caster brakes whenever the cart is stationary. Disengage the brakes to move the cart. Use the cart only on even, level surfaces.



RECORD OF SATISFACTORY CONDITION (THE “RECORD”)

Before putting the cart into service, make a detailed record of its condition. Include observations about all features: pivot points, welds, the container support subassembly, casters, brakes, the handle, pins and other hardware. Thoroughly photograph the unit from multiple angles. All features should be clearly visible. Photograph all labels applied to the cart. Describe where each label is located. Collect all photographs and writings in a single file. This file is a record of the cart in satisfactory condition. Compare the results of each inspection to this *RECORD* to determine whether the unit is in satisfactory condition. Do not use the cart unless it is in satisfactory condition.

INSPECTIONS AND MAINTENANCE

Compare inspection results to the *RECORD*. Do not continue to use the product unless every component is in *SATISFACTORY CONDITION*. Cosmetic changes, like damaged paint/powder coat do not constitute changes from satisfactory condition. However, touchup paint should be applied to all affected areas as soon as damage occurs. Contact *TECHNICAL SERVICE* to order replacement parts. Contact information is provided on the cover page of this manual.

Inspect the following at least once per month:

1. Surfaces – Check all surfaces of the product for dirt or other matter, especially fluids. Clean the surfaces of the stand.
2. Hardware, fasteners – Examine hardware & fasteners (clevis pins, cotter pins, bolts, nuts, etc.). Replace damaged/worn hardware.
3. Handle – Examine the handle for bends, punctures, corrosion/rusting especially on legs where they contact the handle brackets).
4. Lower frame and Container support – Examine the lower frame for wear, breaks, corrosion/rust, metal fatigue, and other forms of damage (e.g. impact damage).
5. Casters – Inspect all 4 casters and the bulldog caster receivers. Replace a caster if its wheel is significantly worn, e.g. does not roll smoothly. Lubricate wheel pivot points as necessary to allow for quiet, uniform rotation. Inspect each caster fork, bearing, axle, wheel hub, mounting plate, and brake lever (swiveling casters only) for damage.
6. Spring – Check the spring for cracks and other damage. Make sure that no debris is caught in the spring.
7. Labels – Replace labels that are missing, damaged, or not easily readable from a reasonable distance.
8. Overall structure – Examine the whole structure for rusting or metal erosion, rot, thinned regions. In particular, examine pivot points, handle brackets, . If rusting is purely superficial, remove the rust/corrosion. Clean the affected area and apply touchup paint. If rusting, rot, or thinning has weakened the material, contact *TECHNICAL SERVICE* for advice.

LABELING DIAGRAM

Label content and locations are subject to change so your product might not be labeled exactly as shown. Replace all labels that are damaged, missing, or not easily readable (e.g. faded). To order replacement labels, contact the technical service and parts department online at <https://www.vestil.com/page-parts-request.php>. Alternatively, you may request replacement parts and/or service by calling (260) 665-7586 and asking the operator to connect you to the [Technical Service/Parts Department](#).



A: Label 1153

MODEL / MODÉLO / MODÈLE _____
WEIGHT / PESO / MASS _____
CAPACITY / CAPACIDAD / CAPACITÉ _____
SERIAL / SERIE / SÉRIE _____
UNITS: 2.2 lb. = 1kg 1" (or 1in.) = 2.54cm 1153

B: Label 658

⚠ WARNING	⚠ ADVERTENCIA	⚠ AVERTISSEMENT
Do not operate or move with unstable loads DO NOT LOAD beyond rated capacity DISTRIBUTE LOAD EVENLY DO NOT sit or ride	No use a mueva con cargas inestables No cargue más de la capacidad tasada DISTRIBUYA LA CARGA A NIVEL NO SE SIENTE o vaya en el carro	Ne pas utiliser avec une charge instable NE PAS CHARGER au-delà du débit nominale DISTRIBUER la charge régulièrement NE PAS VOUS ASSEoir OU VOUS PROMENER sur le chariot

C: Label 208

⚠ WARNING	⚠ ADVERTENCIA	⚠ AVERTISSEMENT
KEEP CLEAR OF PINCH POINT	MANTENGASE ALEJADO DEL PUNTO DE CORTE	SE TENIR À DISTANCE DU POINT DE PINCEMENT

D: Label 212

⚠ WARNING	⚠ ADVERTENCIA	⚠ AVERTISSEMENT
Immobilize by applying all caster brakes and/or floor locks when in use, loading, and unloading.	Inmovilice aplicando todos los frenos de las ruedas y / o bloqueos del piso cuando esté en uso, cargando y descargando.	Immobiliser en appliquant tous les freins des roulettes et / ou les verrous de plancher lors de l'utilisation, du chargement et du déchargement.



LIMITED WARRANTY

Vestil Manufacturing Company ("Vestil") warrants this product to be free of defects in material and workmanship during the warranty period. Our warranty obligation is to provide a replacement for a defective, original part covered by the warranty after we receive a proper request from the Warrantee (you) for warranty service.

Who may request service?

Only a warrantee may request service. You are a warrantee if you purchased the product from Vestil or from an authorized distributor AND Vestil has been fully paid.

Definition of "original part"?

An original part is a part used to make the product as shipped to the Warrantee.

What is a "proper request"?

A request for warranty service is proper if Vestil receives: 1) a photocopy of the Customer Invoice that displays the shipping date; AND 2) a written request for warranty service including your name and phone number. Send requests by one of the following methods:

<u>US Mail</u> Vestil Manufacturing Company 2999 North Wayne Street, PO Box 507 Angola, IN 46703	<u>Fax</u> (260) 665-1339 <u>Phone</u> (260) 665-7586	<u>Email</u> info@vestil.com Enter "Warranty service request" in subject field.
---	--	---

In the written request, list the parts believed to be defective and include the address where replacements should be delivered. After Vestil receives your request for warranty service, an authorized representative will contact you to determine whether your claim is covered by the warranty. Before providing warranty service, Vestil will require you to send the entire product, or just the defective part (or parts), to its facility in Angola, IN.

What is covered under the warranty?

The warranty covers defects in the following original, dynamic parts: motors, hydraulic pumps, motor controllers, and cylinders. It also covers defects in original parts that wear under normal usage conditions ("wearing parts"), such as bearings, hoses, wheels, seals, brushes, and batteries.

How long is the warranty period?

The warranty period for original dynamic components is 90 days. For wearing parts, the warranty period is 90 days. Both warranty periods begin on the date Vestil ships the product to the Warrantee. If the product was purchased from an authorized distributor, the periods begin when the distributor ships the product. Vestil may, at its sole discretion, extend a warranty period for products shipped from authorized distributors by up to 30 days to account for shipping time.

If a defective part is covered by the warranty, what will Vestil do to correct the problem?

Vestil will provide an appropriate replacement for any covered part. An authorized representative of Vestil will contact you to discuss your claim.

What is not covered by the warranty?

The Warrantee (you) are responsible for paying labor costs and freight costs to return the product to Vestil for warranty service.

Events that automatically void this Limited Warranty.

- Misuse;
- Negligent assembly, installation, operation or repair;
- Installation/use in corrosive environments;
- Inadequate or improper maintenance;
- Damage sustained during shipping;
- Collisions or other accidents that damage the product;
- Unauthorized modifications: Do not modify the product IN ANY WAY without first receiving written authorization from Vestil.

Do any other warranties apply to the product?

Vestil Manufacturing Co. makes no other express warranties. All implied warranties are disclaimed to the extent allowed by law. Any implied warranty not disclaimed is limited in scope to the terms of this Limited Warranty. Vestil makes no warranty or representation that this product complies with any state or local design, performance, or safety code or standard. Noncompliance with any such code or standard is not a defect in material or workmanship.