



Vestil Manufacturing Company
 2999 North Wayne Street, P.O. Box 507, Angola, IN 46703
 Telephone: (260) 665-7586 -or- Toll Free (800) 348-0868
 Fax: (260) 665-1339
 Website: www.vestil.com e-Mail: info@vestil.com

LAD-series Portable Warehouse Ladders, 6-12 Steps Instruction Manual



Receiving Instructions

After delivery, remove the packaging from the product. Inspect the product closely to determine whether it sustained damage during transport. If damage is discovered, record a complete description of it on the bill of lading. If the product is undamaged, discard the packaging.

NOTE: The end-user is solely responsible for confirming that product design, use, and maintenance comply with laws, regulations, codes, and mandatory standards applied where the product is used.

Technical Service & Replacement Parts

For answers to questions not addressed in these instructions and to order replacement parts, labels, and accessories, call our Technical Service and Parts Department at (260) 665-7586. The department can also be contacted online at <https://www.vestil.com/page-parts-request.php>.

Electronic Copies of Instruction Manuals

Additional copies of this instruction manual may be downloaded from <https://www.vestil.com/page-manuals.php>.

Table of Contents

Signal Words.....	2
Safety Instructions.....	2
Specifications.....	3
FIGURES 1, 2, 3, 4, 5, 6, 7, & 8: Exploded Parts Diagrams and Bills of Materials.....	4, 5, 6, 7, 8, 9, 10, 11
Installing Casters.....	12
Assembling the Ladder.....	13, 14, 15, 16, & 17
Record of Satisfactory Condition.....	17
National Standards.....	17
Using the Ladder.....	17 - 18
Inspections & Maintenance.....	18
Labeling Diagram.....	19
Limited Warranty.....	20

SIGNAL WORDS

This manual uses SIGNAL WORDS to indicate the likelihood of personal injuries, as well as the probable seriousness of those injuries, if the product is misused in the ways described. Other signal words call attention to uses of the product likely cause property damage. The signal words used appear below along with the meaning of each word:



Identifies a hazardous situation which, if not avoided, WILL result in DEATH or SERIOUS INJURY. Use of this signal word is limited to the most extreme situations.



Identifies a hazardous situation which, if not avoided, COULD result in DEATH or SERIOUS INJURY.



Identifies practices likely to result in product/property damage, such as operation that might damage the crane.

SAFETY INSTRUCTIONS

Vestil strives to identify foreseeable hazards associated with the use of its products. However, no manual can address every conceivable risk. The most effective way to avoid injury is to exercise sound judgment when assembling, using, inspecting, and maintaining this ladder. **Keep a copy of this manual with the ladder at all times.** For example, put the copy inside a plastic pouch and attach the pouch to the frame. **Anyone who uses this ladder must be made aware that a copy of the manual is available and where to find it.**



Improper or careless use could result in serious personal injuries or death.

- **Read and understand the entire manual before assembling, using, inspecting, or servicing the ladder.**
- **DO NOT use this ladder unless you are in good health. NEVER use the ladder while under the influence of alcohol or drugs, including prescription medication that affects balance, perception, or judgment.**
- DO NOT exceed the capacity/rated load. The total weight applied to the ladder (weight of the user plus tools, etc.) must not be greater than the capacity. The capacity is provided on label 287. See [Labeling Diagram](#) on p. 19.
- Wear appropriate footwear. DO NOT wear high-heeled shoes or footwear with smooth soles. DO NOT use the ladder on uneven, sloped, or unstable surfaces. **ONLY use the ladder on even, level, improved surfaces (concrete or asphalt).**
- Make sure that you will not contact overhead objects with either your body or with the ladder during use.
- Avoid electrical shock! Take precautions to prevent any contact, or possible contact, with an energized, insulated conductor (electrical line).
- Remove foreign matter, e.g. mud, from your shoes *before* walking on the ladder. Only wear slip-resistant shoes.
- Only stand on the steps. DO NOT climb on the railing. DO NOT slide on the railing.
- DO NOT access, or egress from, any step from another elevated surface unless the ladder is positively secured against movement.
- ALWAYS face the stairs and use the handrails while ascending and descending the ladder.
- DO NOT increase the height of a step by standing on other objects placed on the ladder.
- Inspect the ladder as described in [Inspections & Maintenance](#) on p. 18. DO NOT use the ladder unless it is in [Satisfactory Condition](#). ONLY use manufacturer-approved replacement parts when repairs are necessary.
- DO NOT use the ladder if either square cap (99-024-027) is worn. See applicable [Exploded View](#) on p. 4-11. Caps should prevent the ladder from sliding. Replace worn or damaged caps before using the ladder.
- ONLY use the ladder to access elevated working positions. DO NOT use the ladder for any other purpose. DO NOT store materials and/or equipment on the steps. Always unload the ladder before leaving it unattended.
- DO NOT position an occupied ladder in front of a door unless that door is secured in an open position, is locked, is attended, or is barricaded.
- DO NOT lean, or reach, over the side rails or handrails of the ladder. Position the ladder as close to the work as possible. Reposition the ladder to prevent overreaching. Overreaching could cause instability and result in a fall.
- Avoid sudden shifts while on the ladder.
- DO NOT push, pull, or lean on the handrails.
- DO NOT skip steps. Climb the ladder one step at a time.
- DO NOT attempt to move the ladder while someone is using it. The ladder must be unoccupied before it is moved.
- DO NOT use the ladder to transport people or objects. DO NOT ride on the ladder.
- DO NOT remove or obscure any label. Each label must be readable, undamaged, and present in the appropriate location. See [Labeling Diagram](#) on p. 19.
- DO NOT modify this ladder! Unauthorized modifications automatically void the [Limited Warranty](#) (p. 20) and might make the ladder unsafe to use.
- While assembling this ladder, confirm that only locking fasteners are provided, i.e. only locking nuts. Contact [Technical Service](#) (info on cover page) if you find non-locking nuts. Only lock nuts should be used. However, lock nuts can only safely be used once. Discard the used lock nut and install a new lock nut after unfastening a connection.

SPECIFICATIONS

Documents that provide specifications for LAD series mobile ladder stands are available online to anyone who visits the Vestil website. Specifications include dimensions, net weight, and capacity information. Acquire the appropriate specifications document by opening this webpage: <https://www.vestil.com/product.php?FID=607>. Click the "Specifications" tab. Scroll the page to the entry for the product you purchased. Click the button in the "PDF" column that looks like a pencil inside a blue-bordered box. A PDF file will open. This file is the specifications document. Print a copy of the document as soon as your ladder is delivered and keep it with your copy of this manual. If you encounter difficulties while trying to obtain a copy of the specifications document, contact [Technical Service](#). Contact information is provided on the cover page of this manual.

The following is an exemplar specifications document. In this case, it shows a LAD-6-14-G.

6-STEP ROLLING STEEL WAREHOUSE LADDER - LAD-6-14-G APPROX WEIGHT: 173.2481 lbs. DOES NOT INCLUDE WEIGHT OF POWER OR PACKAGING!!!

*** ANY ADDITIONS, DELETIONS, OR OMISSIONS MUST BE CORRECTED ON THIS DRAWING AS THIS DRAWING WILL BE CONSIDERED ALL INCLUSIVE ***

ALL GRAPHICS PROVIDED ARE FOR REFERENCE ONLY. IF CERTAIN DIMENSIONS ARE CRITICAL PLEASE VERIFY THOSE DIMENSIONS WITH YOUR SALESPERSON

STANDARD FEATURES

MODEL NUMBER IS LAD-6-14-G
 OVERALL WIDTH IS 34 1/4"
 USABLE WIDTH IS 23 9/16"
 OVERALL LENGTH IS 53 15/16"
 USABLE LENGTH IS 45 1/4"
 OVERALL HEIGHT IS 90"
 TOP STEP HEIGHT IS 60"
 STEP TYPE IS GRIP STRUT
 CLIMB ANGLE IS 58°
 STEP DEPTH IS 7"
 TOP STEP DEPTH IS 14"
 MAX CAPACITY IS 350 LBS
 WHEEL SIZE IS Ø10"
 FRONT WHEEL SIZE IS Ø3"
 POWDER COAT FINISH
 COLOR IS BLUE, BOTTOM STEP IS YELLOW

NOTE

SOME ASSEMBLY REQUIRED
 TOOL TRAY SOLD SEPARATELY
 SAFETY GATE SOLD SEPARATELY

SPECIAL FEATURES

NONE

DIMENSION TOLERANCE ± 1/4"

I, THE UNDERSIGNED, AGREE THAT THE PRODUCT AS REPRESENTED SATISFIES DESIGN AND DIMENSION REQUIREMENTS. I ALSO ACKNOWLEDGE MY DUTY TO CONFIRM PRODUCT AND INSTALLATION COMPLIANCE WITH ALL APPLICABLE FEDERAL, STATE AND LOCAL REGULATIONS AND STANDARDS.

ALL SPECIAL UNITS ARE NON-RETURNABLE
 [] As drawn [] As marked

Signed: _____ Date: _____

LEAD TIME WILL START UPON RECEIPT OF SIGNED APPROVAL DRAWING

FOR INTERNAL USE ONLY PROJECT SIGN OFF	DISTRIBUTOR'S NAME: VESTIL MANUFACTURING		P.O.# X
SALES			W.O.# X
ENG.	DRAWN BY:	DATE:	SALES: X
FAB.	REFERENCE: X	SCALE: 1:22	FILE NAME:
POWER	QUOTED LEAD TIME: X	QUOTE # X	44-007-164

NOTE: If your model is not included on the webpage, or if you cannot access and/or print the document, contact the [Technical Service Dept.](#) Contact information is provided on the front page of this manual.

FIG. 1: Foot Lock Mechanism Exploded View and Bill of Materials

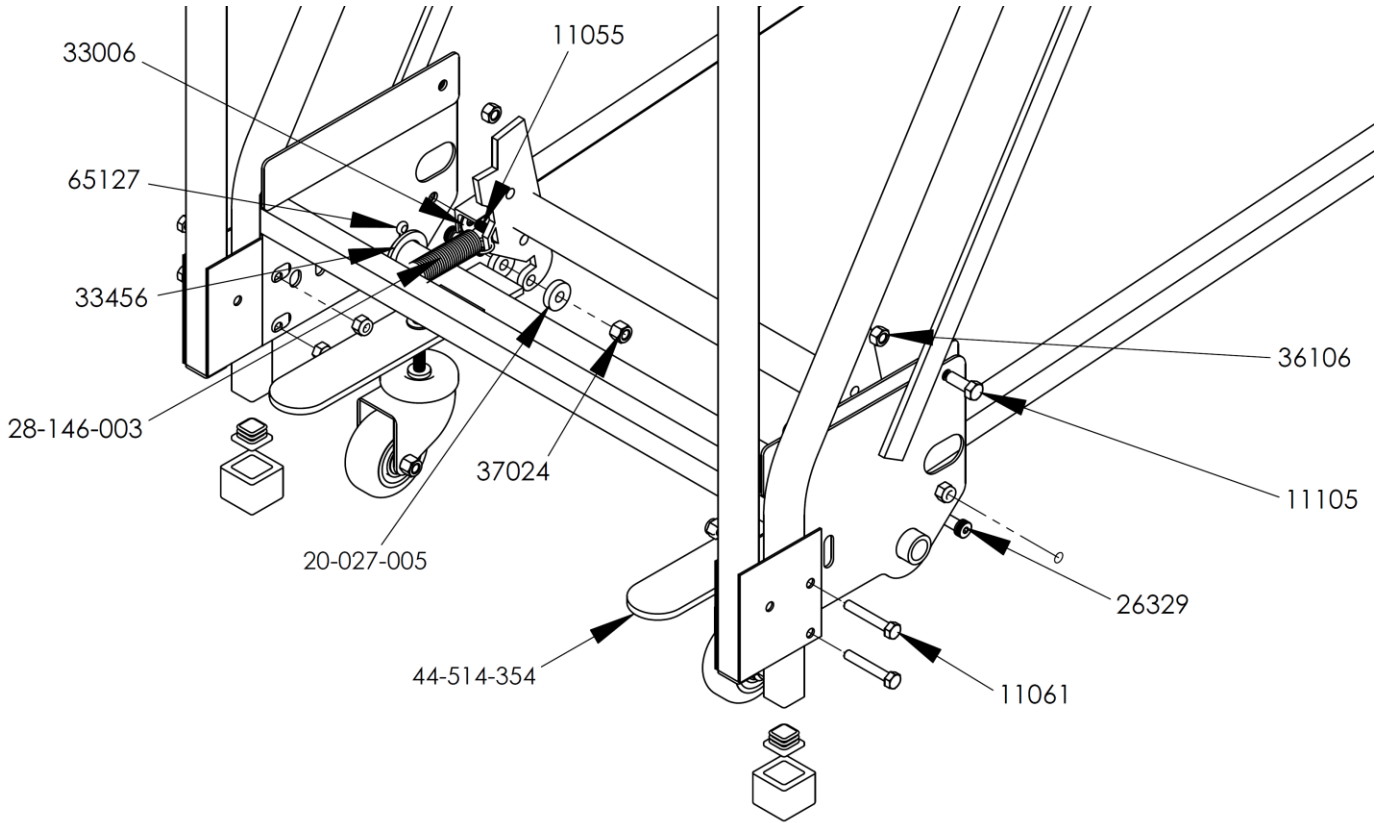

Part no.	Description	Quantity
11055	$\frac{5}{16}$ in. – 18 x 1in. HHCS #2 zinc-plated bolt	2
11061	$\frac{5}{16}$ in. – 18 x 2in. HHCS #2 zinc-plated bolt	4
11105	$\frac{3}{8}$ in. – 16 x 1in. hex head bolt	2
26329	$\frac{3}{8}$ in. shoulder x $\frac{3}{4}$ in. x $\frac{5}{16}$ in. – 18	2
33006	$\frac{5}{16}$ in. USS zinc-plated flat washer	2
33456	1 $\frac{1}{8}$ in. I.D. 10 gauge machine bushing	2
36106	$\frac{3}{8}$ in. – 16 zinc-plated hex nut	2
37024	$\frac{3}{8}$ in. Nylock insert nut	4
65127	$\frac{3}{16}$ in. x 2in. zinc-plated cotter pin	2
20-027-005	Roller guide	4
28-146-003	Spring	2
44-514-354	Weldment, frame, caster pivot foot lock “caster bracket”	1

FIG. 2: LAD-6-14-P, LAD-6-14-G, LAD-6-21-P, & LAD-6-21-G Exploded View and Bill of Materials

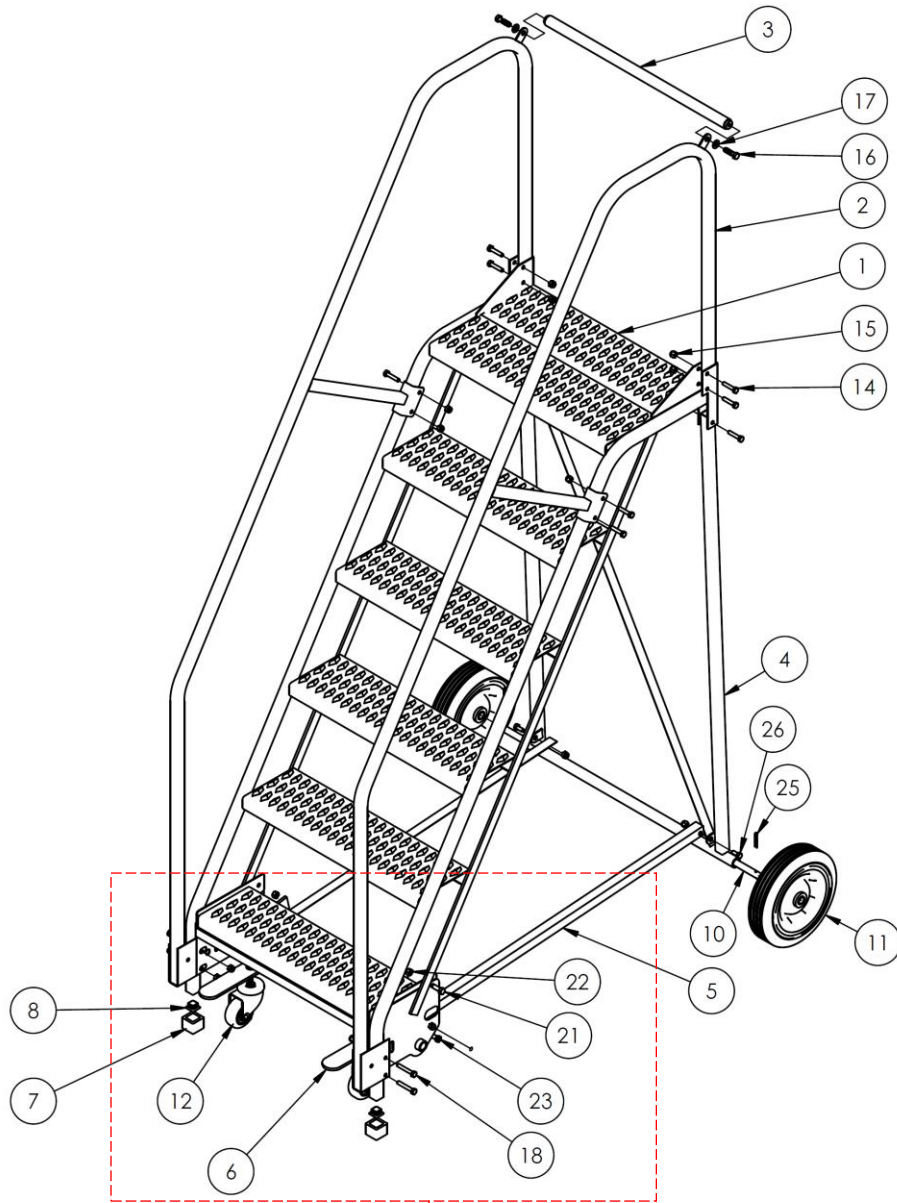

See FIG. 1 on p. 4

Item	Part no.	Description	Quantity
1	44-647-165	Weldment, 6-step frame: LAD-6-14-G	1
	44-647-158	LAD-6-14-P	
	44-647-218	LAD-6-21-G	
	44-647-224	LAD-6-21-P	
2	44-524-122	Weldment, handrail, 6-step ladder: LAD-6-14-G & LAD-6-14-P	2
	44-524-128	LAD-6-21-G & LAD-6-21-P	
3	44-514-314	Weldment, frame, back platform	1
4	44-514-396	Weldment, back leg, 6-step	1
5	44-014-233	Frame, base support: LAD-6-14-G & LAD-6-14-P	2
	44-014-320	LAD-6-21-G & LAD-6-21-P	
6	44-514-354	Weldment, frame, caster pivot foot lock	1
7	99-024-027	1" x 1", 60 duro. square cap	2
8	99-025-025	1" plastic plug	2
9	28-146-003	Spring	2
10	44-112-007	Wheel axle	1
11	16-132-310	10" x 2 1/2" wheel with 16mm steel hub	2
12	16-132-164	Caster, front	2
13	20-027-005	Roller guide	4
14	11059	5/16" - 18 x 1 1/2" zinc-plated #2 bolt	10
15	37021	5/16" - 18 zinc-plated #2 Nylon lock nut	18
16	11108	3/8" - 16 UNC x 1 3/8" zinc-plated hex cap screw	2
17	33008	3/8" zinc-plated USS flat washer	8
18	11061	5/16" - 18 x 2" HHCS #2 zinc-plated bolt	4
19	33456	1 1/8" I.D. 10 gauge machine bushing	2
20	65127	3/16" x 2" zinc-plated cotter pin	2
21	11105	3/8" - 16 x 1in. hex head bolt	2
22	36106	3/8" - 16 zinc-plated hex nut	2
23	26329	3/8" shoulder x 3/4" x 5/16" - 18 bolt	2
24	37024	3/8" Nylock insert nut	4
25	65125	3/16" x 1 1/2" zinc-plated cotter pin	2
26	11053	5/16" - 18 x 3/4" HHCS #2 zinc-plated bolt	2
27	33006	5/16" USS zinc-plated USS flat washer	2
28	11055	5/16" - 18 x 1" HHCS #2 zinc-plated bolt	2

NOTE: See FIG. 1 on p. 4 for a detailed exploded view of the Foot Lock Mechanism.

FIG. 3: LAD-7-14-G, LAD-7-14-P, LAD-7-21-G & LAD-7-21-P Exploded View and Bill of Materials

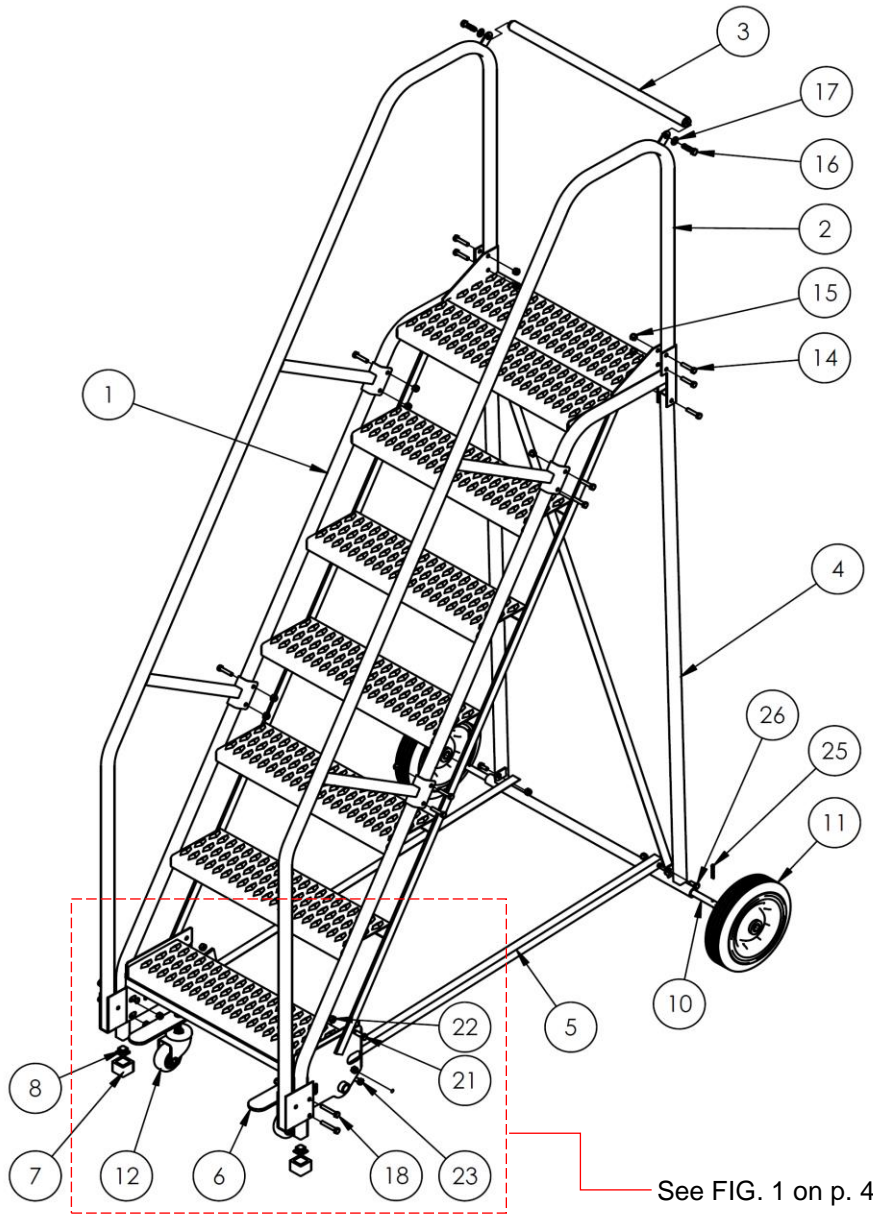

See FIG. 1 on p. 4

Item	Part no.	Description	Quantity
1	44-647-166	Weldment, 7-step frame: LAD-7-14-G	1
	44-647-159	LAD-7-14-P	
	44-647-225	LAD-7-21-G	
	44-647-219	LAD-7-21-P	
2	44-524-123	Weldment, handrail, 7-step ladder: LAD-7-14-G & LAD-7-14-P	2
	44-524-129	LAD-7-21-G & LAD-7-21-P	
3	44-514-314	Weldment, frame, back platform	1
4	44-514-397	Weldment, back leg, 7-step	1
5	44-014-320	Frame, base support: LAD-7-14-G & LAD-7-14-P	2
	44-014-238	LAD-7-21-G & LAD-7-21-P	
6	44-514-354	Weldment, frame, caster pivot foot lock	1
7	99-024-027	1" x 1", 60 duro. square cap	2
8	99-025-025	1" plastic plug	2
9	28-146-003	Spring	2
10	44-112-007	Wheel axle	1
11	16-132-310	10" x 2 1/2" wheel with 16mm steel hub	2
12	16-132-164	Caster, front	2
13	20-027-005	Roller guide	4
14	11059	5/16" - 18 x 1 1/2" zinc-plated #2 bolt	14
15	37021	5/16" - 18 zinc-plated #2 Nylon lock nut	22
16	11108	3/8" - 16 UNC x 1 3/8" zinc-plated hex cap screw	2
17	33008	3/8" zinc-plated USS flat washer	8
18	11061	5/16" - 18 x 2" HHCS #2 zinc-plated bolt	4
19	33456	1 1/8" I.D. 10 gauge machine bushing	2
20	65127	3/16" x 2" zinc-plated cotter pin	2
21	11105	3/8" - 16 x 1in. hex head bolt	2
22	36106	3/8" - 16 zinc-plated hex nut	2
23	26329	3/8" shoulder x 3/4" x 5/16" - 18 bolt	2
24	37024	3/8" Nylock insert nut	4
25	65125	3/16" x 1 1/2" zinc-plated cotter pin	2
26	11053	5/16" - 18 x 3/4" HHCS #2 zinc-plated bolt	2
27	33006	5/16" USS zinc-plated USS flat washer	2
28	11055	5/16" - 18 x 1" HHCS #2 zinc-plated bolt	2

NOTE: See FIG. 1 on p. 4 for a detailed exploded view of the Foot Lock Mechanism.

FIG. 4: LAD-8-14-G, LAD-8-14-P, LAD-8-21-G, & LAD-8-21-P Exploded View and Bill of Materials

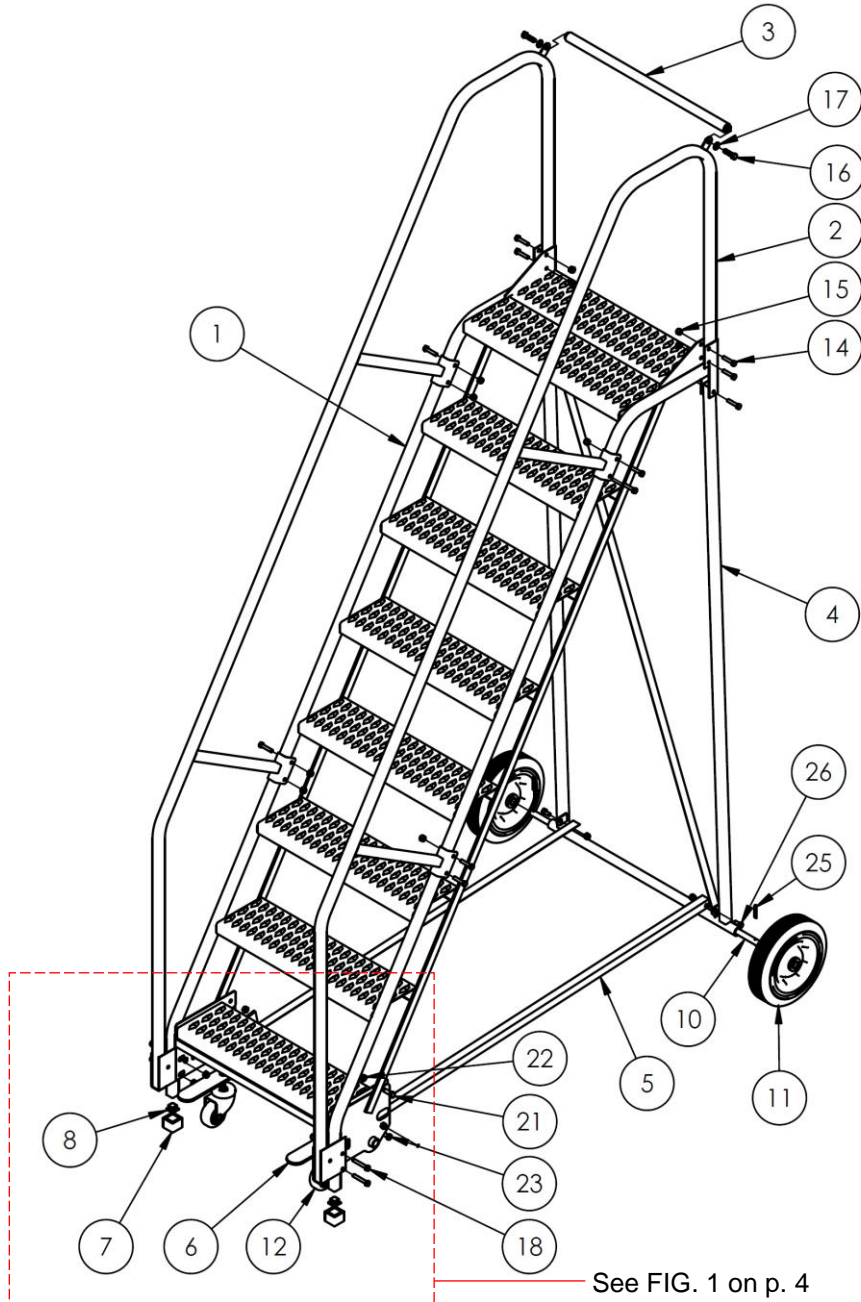

Item	Part no.	Description	Quantity
1	44-647-167	Weldment, 8-step frame:	1
	44-647-160	LAD-8-14-G	
	44-647-226	LAD-8-14-P	
	44-647-220	LAD-8-21-P	
2	44-524-124	Weldment, handrail, 8-step ladder:	2
	44-524-130	LAD-8-14-G & LAD-8-14-P LAD-8-21-G & LAD-8-21-P	
3	44-514-314	Weldment, frame, back platform	1
4	44-514-319	Weldment, back leg, 8-step	1
5	44-014-238	Frame, base support:	2
	44-014-243	LAD-8-14-G & LAD-8-14-P LAD-8-21-G & LAD-8-21-P	
6	44-514-354	Weldment, frame, caster pivot foot lock	1
7	99-024-027	1" x 1", 60 duro. square cap	2
8	99-025-025	1" plastic plug	2
9	28-146-003	Spring	2
10	44-112-007	Wheel axle	1
11	16-132-310	10" x 2 1/2" wheel with 16mm steel hub	2
12	16-132-164	Caster, front	2
13	20-027-005	Roller guide	4
14	11059	5/16" - 18 x 1 1/2" zinc-plated #2 bolt	14
15	37021	5/16" - 18 zinc-plated #2 Nylon lock nut	22
16	11108	3/8" - 16 UNC x 1 3/8" zinc-plated hex cap screw	2
17	33008	3/8" zinc-plated USS flat washer	8
18	11061	5/16" - 18 x 2" HHCS #2 zinc-plated bolt	4
19	33456	1 1/8" I.D. 10 gauge machine bushing	2
20	65127	3/16" x 2" zinc-plated cotter pin	2
21	11105	3/8" - 16 x 1in. hex head bolt	2
22	36106	3/8" - 16 zinc-plated hex nut	2
23	26329	3/8" shoulder x 3/4" x 5/16" - 18 bolt	2
24	37024	3/8" Nylock insert nut	4
25	65125	3/16" x 1 1/2" zinc-plated cotter pin	2
26	11053	5/16" - 18 x 3/4" HHCS #2 zinc-plated bolt	2
27	33006	5/16" USS zinc-plated USS flat washer	2
28	11055	5/16" - 18 x 1" HHCS #2 zinc-plated bolt	2

NOTE: See FIG. 1 on p. 4 for a detailed exploded view of the Foot Lock Mechanism.

FIG. 5: LAD-9-14-G, LAD-9-14-P, LAD-9-21-G, & LAD-9-21-P Exploded View and Bill of Materials

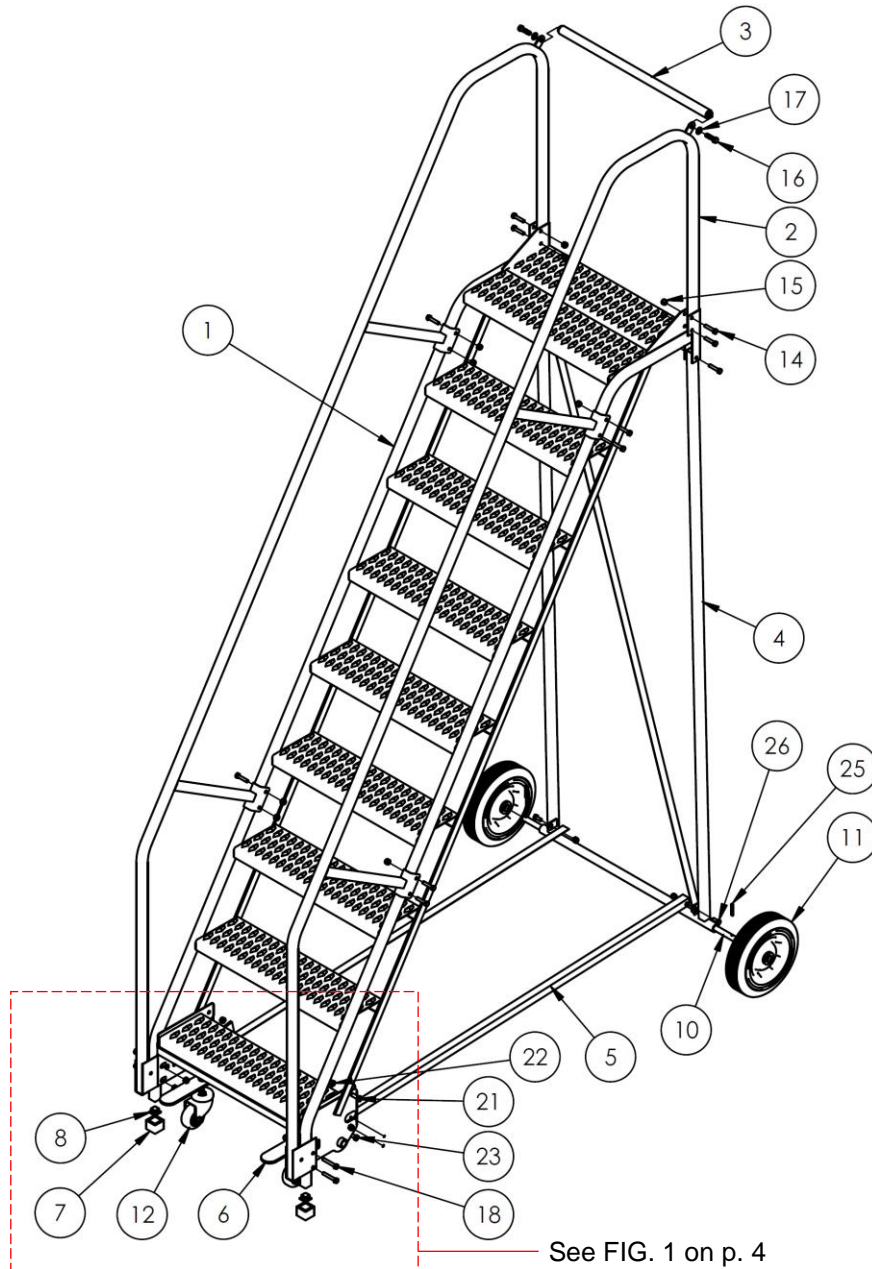

Item	Part no.	Description	Quantity
1	44-647-168	Weldment, 9-step frame: LAD-9-14-G	1
	44-647-161	LAD-9-14-P	
	44-647-227	LAD-9-21-G	
	44-647-221	LAD-9-21-P	
2	44-524-125	Weldment, handrail, 9-step ladder: LAD-9-14-G & LAD-9-14-P	2
	44-524-131	LAD-9-21-G & LAD-9-21-P	
3	44-514-314	Weldment, frame, back platform	1
4	44-514-320	Weldment, back leg, 9-step	1
5	44-014-243	Frame, base support: LAD-9-14-G & LAD-9-14-P	2
	44-014-400	LAD-9-21-G & LAD-9-21-P	
6	44-514-354	Weldment, frame, caster pivot foot lock	1
7	99-024-027	1" x 1", 60 duro. square cap	2
8	99-025-025	1" plastic plug	2
9	28-146-003	Spring	2
10	44-112-007	Wheel axle	1
11	16-132-310	10" x 2 1/2" wheel with 16mm steel hub	2
12	16-132-164	Caster, front	2
13	20-027-005	Roller guide	4
14	11059	5/16" - 18 x 1 1/2" zinc-plated #2 bolt	14
15	37021	5/16" - 18 zinc-plated #2 Nylon lock nut	22
16	11108	3/8" - 16 UNC x 1 3/8" zinc-plated hex cap screw	2
17	33008	3/8" zinc-plated USS flat washer	8
18	11061	5/16" - 18 x 2" HHCS #2 zinc-plated bolt	4
19	33456	1 1/8" I.D. 10 gauge machine bushing	2
20	65127	3/16" x 2" zinc-plated cotter pin	2
21	11105	3/8" - 16 x 1in. hex head bolt	2
22	36106	3/8" - 16 zinc-plated hex nut	2
23	26329	3/8" shoulder x 3/4" x 5/16" - 18 bolt	2
24	37024	3/8" Nylock insert nut	4
25	65125	3/16" x 1 1/2" zinc-plated cotter pin	2
26	11053	5/16" - 18 x 3/4" HHCS #2 zinc-plated bolt	2
27	33006	5/16" USS zinc-plated USS flat washer	2
28	11055	5/16" - 18 x 1" HHCS #2 zinc-plated bolt	2

NOTE: See FIG. 1 on p. 4 for a detailed exploded view of the Foot Lock Mechanism.

FIG. 6: LAD-10-14-G, LAD-10-14-P, LAD-10-21-G, & LAD-10-21-P Exploded View and Bill of Materials

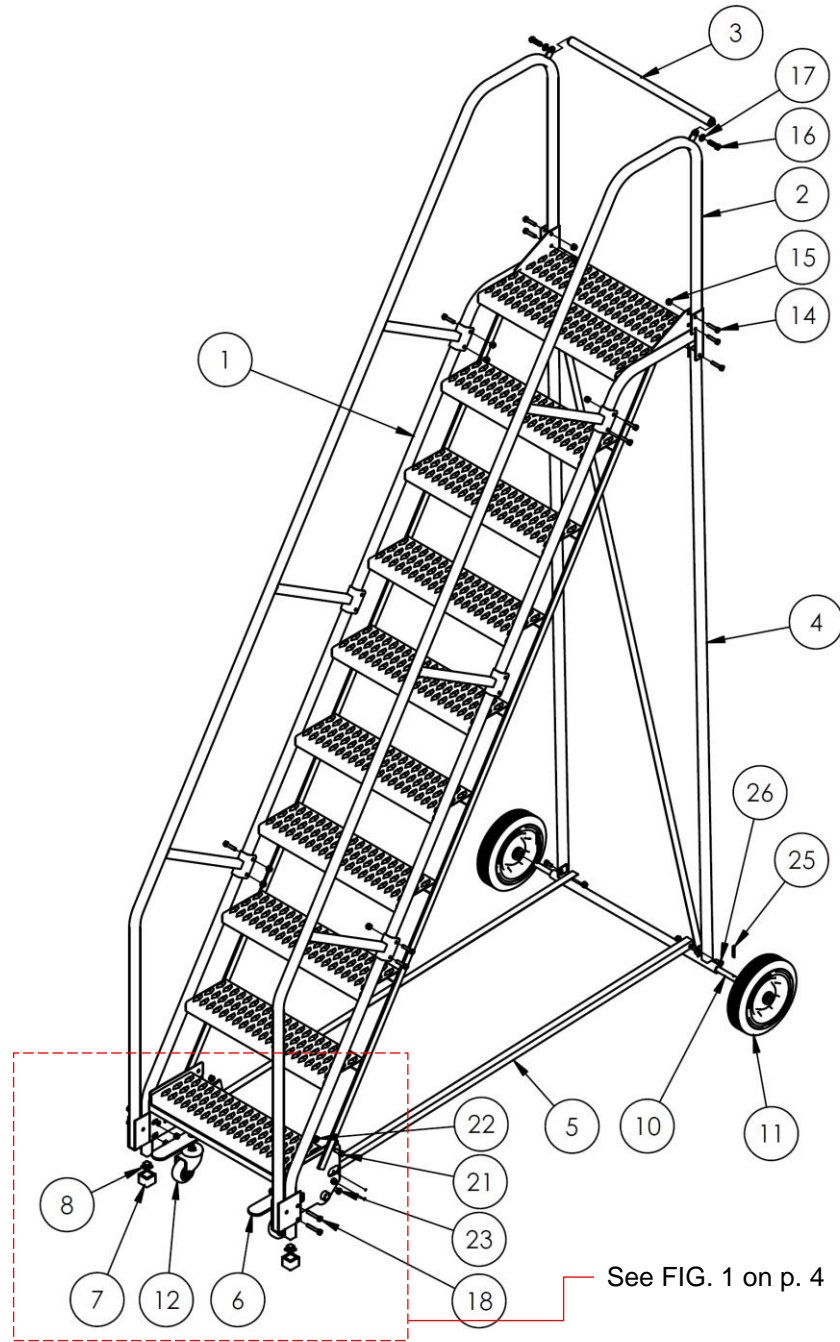

Item	Part no.	Description	Quantity
1	44-647-169	Weldment, 10-step frame:	1
	44-647-162	LAD-10-14-G	
	44-647-228	LAD-10-14-P	
	44-647-222	LAD-10-21-G	
2	44-524-126	Weldment, handrail, 10-step ladder:	2
	44-524-132	LAD-10-14-G & LAD-10-14-P	
3	44-514-314	LAD-10-21-G & LAD-10-21-P	1
4	44-514-321	Weldment, back platform	1
5	44-514-321	Weldment, back leg, 10-step	1
	44-014-400	Frame, base support:	
6	44-014-401	LAD-10-14-G & LAD-10-14-P	2
	44-514-354	LAD-10-21-G & LAD-10-21-P	
7	99-024-027	Weldment, frame, caster pivot foot lock	1
8	99-025-025	1" x 1", 60 duro. square cap	2
9	99-025-025	1" plastic plug	2
10	28-146-003	Spring	2
11	44-112-007	Wheel axle	1
12	16-132-310	10" x 2 1/2" wheel with 16mm steel hub	2
13	16-132-164	Caster, front	2
14	20-027-005	Roller guide	4
15	11059	5/16" - 18 x 1 1/2" zinc-plated #2 bolt	14
16	37021	5/16" - 18 zinc-plated #2 Nylon lock nut	22
17	11108	3/8" - 16 UNC x 1 3/8" zinc-plated hex cap screw	2
18	33008	3/8" zinc-plated USS flat washer	8
19	11061	5/16" - 18 x 2" HHCS #2 zinc-plated bolt	4
20	33456	1 1/8" I.D. 10 gauge machine bushing	2
21	65127	3/16" x 2" zinc-plated cotter pin	2
22	11105	3/8" - 16 x 1in. hex head bolt	2
23	36106	3/8" - 16 zinc-plated hex nut	2
24	26329	3/8" shoulder x 3/4" x 5/16" - 18 bolt	2
25	37024	3/8" Nylock insert nut	4
26	65125	3/16" x 1 1/2" zinc-plated cotter pin	2
27	11053	5/16" - 18 x 3/4" HHCS #2 zinc-plated bolt	2
28	33006	5/16" USS zinc-plated USS flat washer	2
	11055	5/16" - 18 x 1" HHCS #2 zinc-plated bolt	2

NOTE: See FIG. 1 on p. 4 for a detailed exploded view of the Foot Lock Mechanism.

FIG. 7: LAD-11-14-G, LAD-11-14-P, LAD-11-21-G, & LAD-11-21-P Exploded View and Bill of Materials

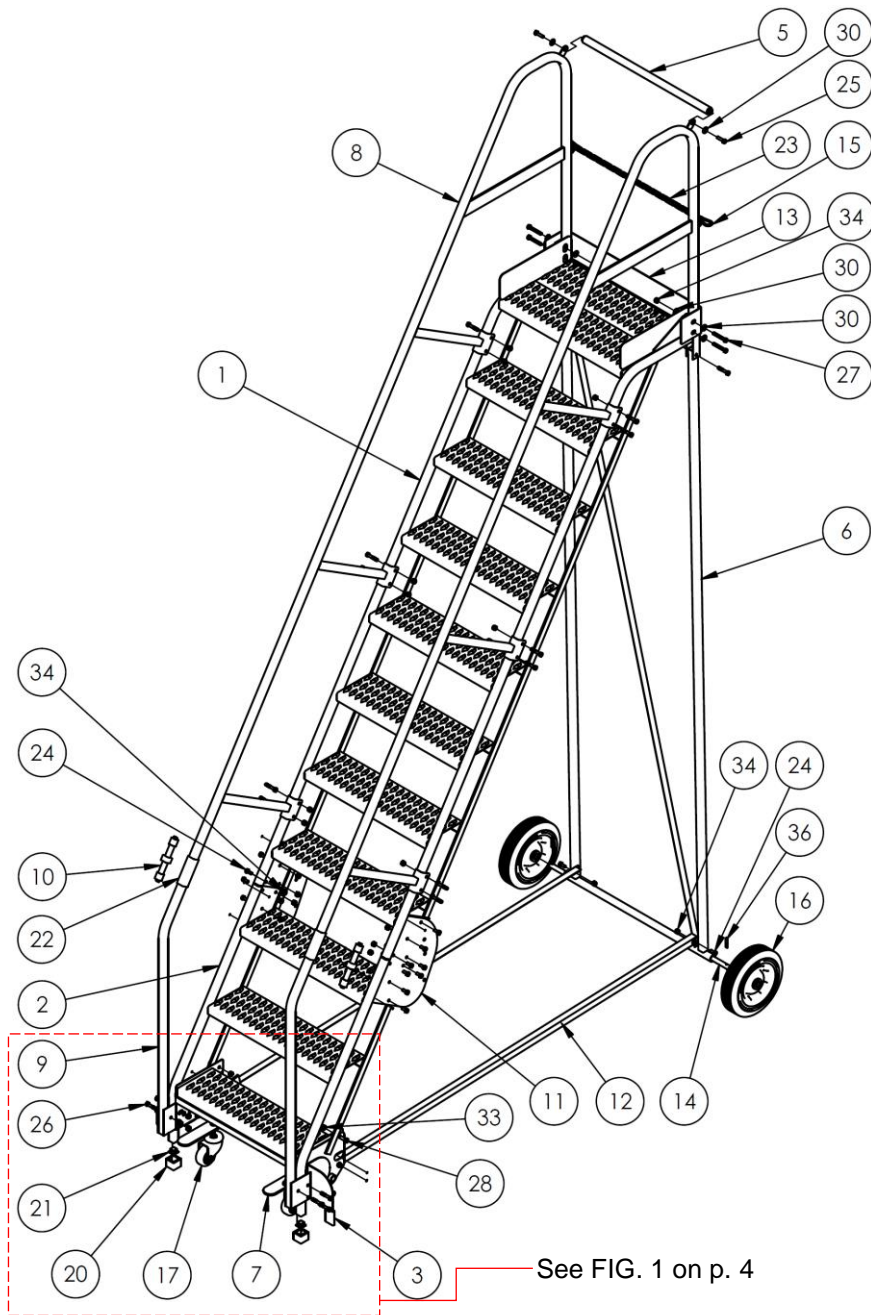

Item	Part no.	Description	Quantity
1	44-647-256	Weldment, step 58°, warehouse, upper:	1
	44-647-255	LAD-11-14-G	
	44-647-258	LAD-11-21-G	
	44-647-257	LAD-11-21-P	
2	44-647-260	Weldment, 11-step, frame, lower:	1
	44-647-259	LAD-11-14-G	
		LAD-11-14-P & LAD-11-21-G & LAD-11-21-P	
3	44-514-310	Assembly, outrigger, right	1
4	44-514-311	Assembly, outrigger, left	1
5	44-514-314	Weldment, frame, back platform	1
6	44-514-322	Weldment, back leg, 11-step	1
7	44-514-354	Weldment, frame, caster pivot foot lock	1
8	44-524-126	Weldment, handrail, 58° climb, 10-step:	2
	44-524-132	LAD-11-14-G & LAD-11-14-P	
9	44-524-166	Weldment, handrail, bottom, 11-step warehouse	2
10	44-645-002	Assembly, specialty hardware, handrail splice	2
11	44-012-008	Hinge plates, connector	2
12	44-014-401	Frame, base support:	2
	44-014-402	LAD-11-14-G & LAD-11-14-P	
13	44-015-001	Toeguard, removable back plate, formed	1
14	44-112-007	Wheel axle	1
15	08-145-008	1/4" snap hook	2
16	16-132-310	10" x 2 1/2" wheel, 16mm steel hub	2
17	16-132-164	Caster	2
18	20-027-005	Roller guide	4
19	28-146-003	Spring	2
20	99-024-027	1" x 1", 60 duro., square cap	2
21	99-025-025	1" plastic plug, black	2
22	99-025-028	Grip, 1" square tube sleeve	2
23	99-145-031	3/16" chain, 24" long	1
24	11053	5/16" - 18 x 3/4" HHCS #2 zinc-plated bolt	22
25	11057	5/16" - 18 UNC x 1 1/4" HHCS #2 zinc-plated bolt	2
26	11060	5/16" - 18 UNC x 1 3/4" HHCS #2 zinc-plated bolt	20
27	11062	5/16" - 18 UNC x 2 1/4" HHCS #2 zinc-plated bolt	4
28	11105	3/8" - 16 x 1in. hex head bolt	2
29	26329	3/8" shoulder x 3/4" x 5/16" - 18 bolt	2
30	33006	5/16" USS zinc-plated USS flat washer	10
31	33008	3/8" zinc-plated USS flat washer	6
32	33456	1 1/8" I.D. 10 gauge machine bushing	2
33	36106	3/8" - 16 zinc-plated hex nut	2
34	37021	5/16" - 18 zinc-plated #2 Nylon lock nut	46
35	37024	3/8" Nylock insert nut	4
36	65125	3/16" x 1 1/2" zinc-plated cotter pin	2
37	65127	3/16" x 2" zinc-plated cotter pin	2

NOTE: See FIG. 1 on p. 4 for a detailed exploded view of the Foot Lock Mechanism.

FIG. 8: LAD-12-14-G, LAD-12-14-P, LAD-12-21-G, & LAD-12-21-P Exploded View and Bill of Materials

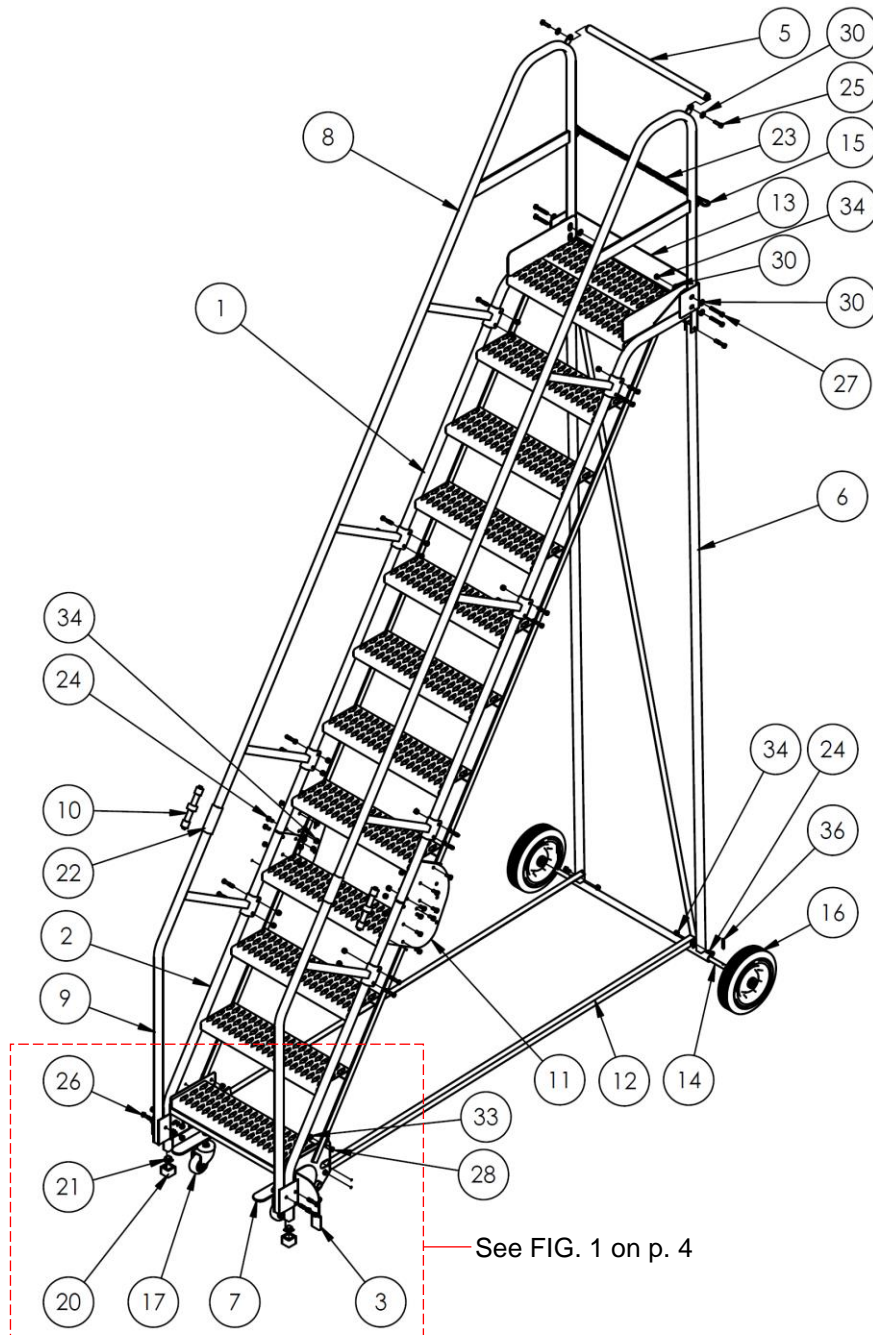

Item	Part no.	Description	Quantity
1	44-647-256	Weldment, step 58°, warehouse, upper:	1
	44-647-255	LAD-12-14-G	
	44-647-258	LAD-12-21-G	
	44-647-257	LAD-12-21-P	
2	44-647-262	Weldment, 12-step, frame, lower:	1
	44-647-261	LAD-12-14-G & LAD-12-21-G & LAD-12-21-P	
3	44-514-310	Assembly, outrigger, right	1
4	44-514-311	Assembly, outrigger, left	1
5	44-514-314	Weldment, frame, back platform	1
6	44-514-323	Weldment, back leg, 12-step	1
7	44-514-354	Weldment, frame, caster pivot foot lock	1
8	44-524-147	Weldment, handrail, 58° climb, 8-step:	2
	44-524-148	LAD-12-14-G & LAD-12-14-P	
	44-524-150	LAD-12-21-G & LAD-12-21-P	
9	44-524-150	Weldment, handrail, 12-step warehouse	2
10	44-645-001	Assembly, specialty hardware, handrail splice	2
11	44-012-008	Hinge plates, connector	2
12	44-014-402	Frame, base support:	2
	44-014-403	LAD-12-14-G & LAD-12-14-P	
	44-014-403	LAD-12-21-G & LAD-12-21-P	
13	44-015-001	Toeguard, removable back plate, formed	1
14	44-112-007	Wheel axle	1
15	08-145-008	1/4" snap hook	2
16	16-132-310	10" x 2 1/2" wheel, 16mm steel hub	2
17	16-132-164	Caster	2
18	20-027-005	Roller guide	4
19	28-146-003	Spring	2
20	99-024-027	1" x 1", 60 duro., square cap	2
21	99-025-025	1" plastic plug, black	2
22	99-025-028	Grip, 1" square tube sleeve	2
23	99-145-031	3/16" chain, 24" long	1
24	11053	5/16" - 18 x 3/4" HHCS #2 zinc-plated bolt	22
25	11057	5/16" - 18 UNC x 1 1/4" HHCS #2 zinc-plated bolt	2
26	11060	5/16" - 18 UNC x 1 3/4" HHCS #2 zinc-plated bolt	24
27	11062	3/16" - 18 UNC x 2 1/4" HHCS #2 zinc-plated bolt	4
28	11105	3/8" - 16 x 1 in. hex head bolt	2
29	26329	3/8" shoulder x 3/4" x 5/16" - 18 bolt	2
30	33006	3/16" USS zinc-plated USS flat washer	10
31	33008	3/8" zinc-plated USS flat washer	6
32	33456	1 1/8" I.D. 10 gauge machine bushing	2
33	36106	3/8" - 16 zinc-plated hex nut	2
34	37021	3/16" - 18 zinc-plated #2 Nylon lock nut	50
35	37024	3/8" Nylock insert nut	4
36	65125	3/16" x 1 1/2" zinc-plated cotter pin	2
37	65127	3/16" x 2" zinc-plated cotter pin	2

NOTE: See FIG. 1 on p. 4 for a detailed exploded view of the Foot Lock Mechanism.

INSTALLING CASTERS

1. Apply a permanent thread bonding and sealing compound like Loctite® Threadlocker Red 271™ to the threads of one of the stem casters (16-132-164). Follow the directions provided with the thread compound.
2. Insert the (threaded) stem of a caster through the hole in a caster bracket.
3. Put a $\frac{3}{8}$ " flat washer (33008) over the stem.
4. Tighten a $\frac{3}{8}$ "-16 lock nut (37024) on the stem.
5. Repeat steps 1-4 with the remaining caster. Install the caster in the other caster bracket.

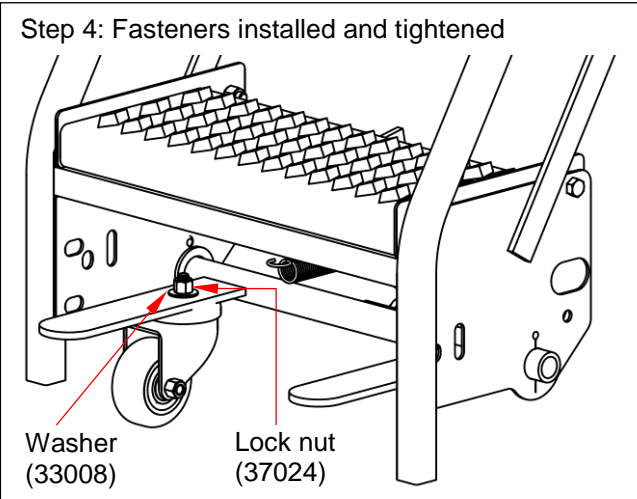
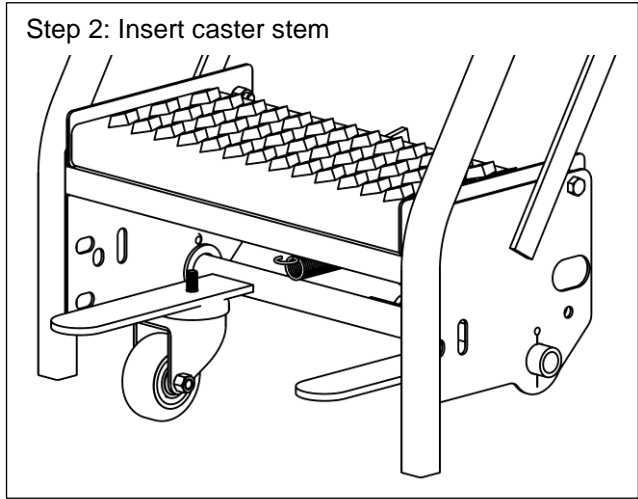
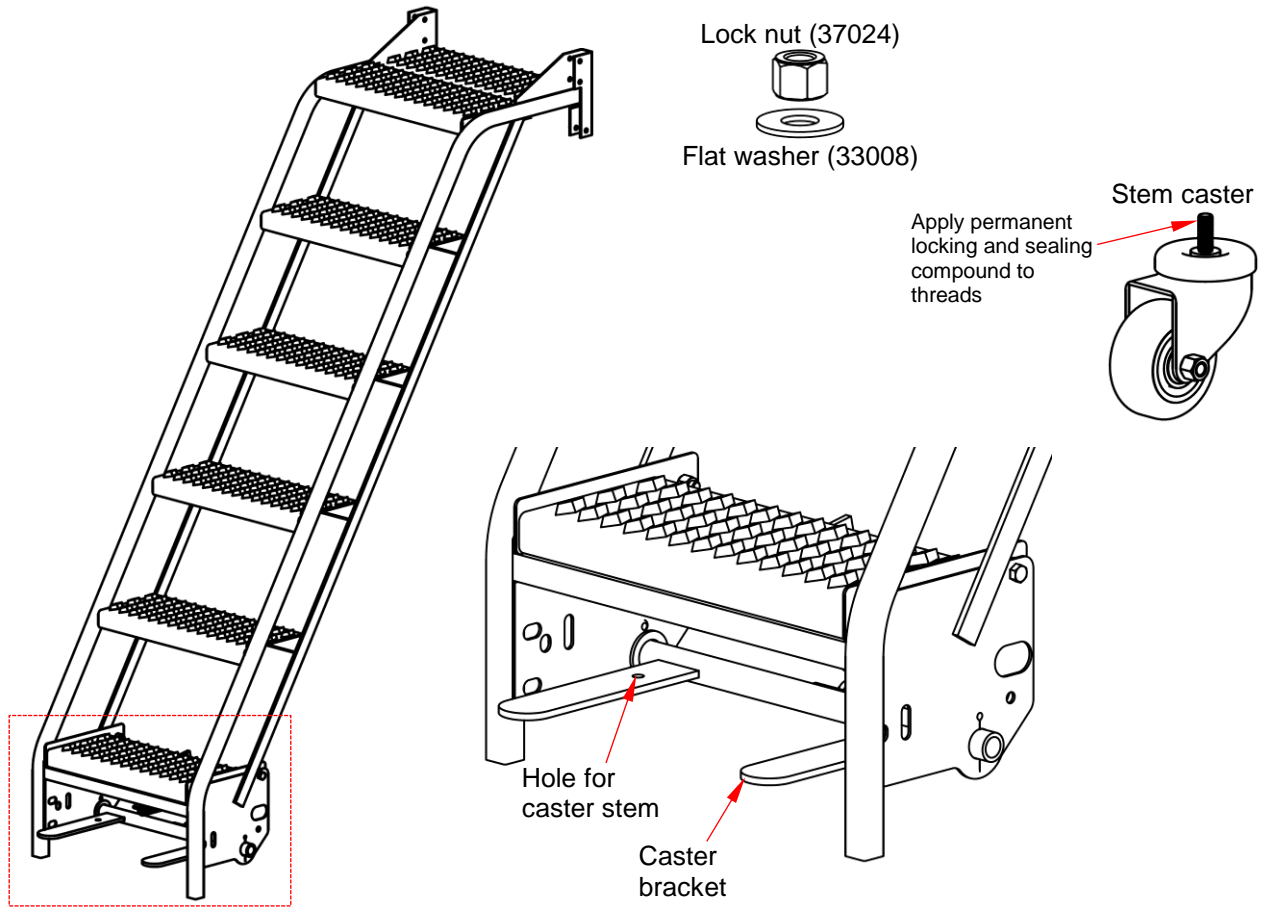

ASSEMBLING THE LADDER (AT LEAST 2 PERSONS ARE NEEDED)

⚠️ WARNING

Improper assembly might make this ladder unsafe to use.

- Visually inspect all ladder components immediately after delivery and *before* assembling the ladder for damage that might have occurred during shipping. DO NOT assemble or use the ladder stand if you notice any damage to one or more of the steps or to other structural element (step weldment, back leg weldment, base supports, and handrails) of the ladder. Using the ladder stand with a weakened frame member could result in serious personal injuries.
- DO NOT assemble the ladder by yourself. Work with at least 1 other person to assemble the ladder.
- **Read the entire instruction manual before assembling this ladder.**

The following tools are necessary to assemble the ladder: a) $\frac{3}{8}$ " drive ratchet with $\frac{5}{16}$ " and $\frac{3}{8}$ " sockets or two (2) $\frac{5}{16}$ " and two (2) $\frac{3}{8}$ " wrenches (open end or box end); b) Pliers; and c) Rubber mallet.

Numbers in the diagrams and in parentheses () correspond to part numbers in the *BILLS OF MATERIALS* on pages 4, 5, 6, 7, 8, 9, 10, & 11. Refer to the appropriate exploded view and bill of materials for your ladder while assembling it. NOTE: Step 1 depicts the step frame weldment with casters installed. If your ladder is delivered without these casters installed, go to [INSTALLING CASTERS](#) on p. 12 and follow the caster installation instructions before assembling the ladder.

Step 1 [11 and 12-step models only]: Attach the upper (1) and lower (2) stair weldments using hinge plates (11) using $\frac{5}{16}$ " – 18 hardware as shown in the illustration below. Install bolts through the bolt holes in the hinge plates and the hinge brackets highlighted with arrows.

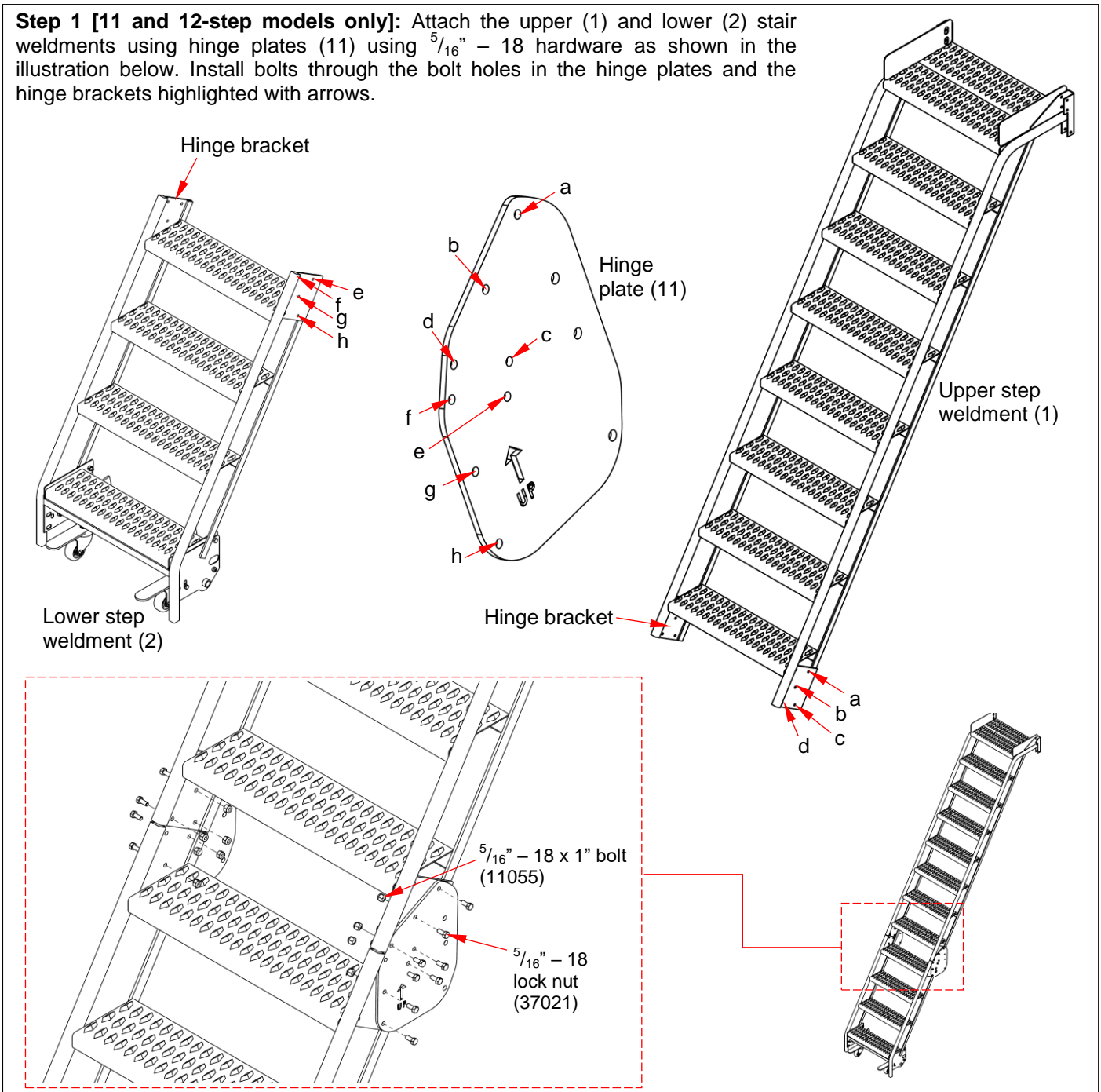

Step 2: Fasten the back leg weldment to the stair frame weldment with $\frac{5}{16}$ in. hardware. Be sure to orient the back leg weldment as shown below.

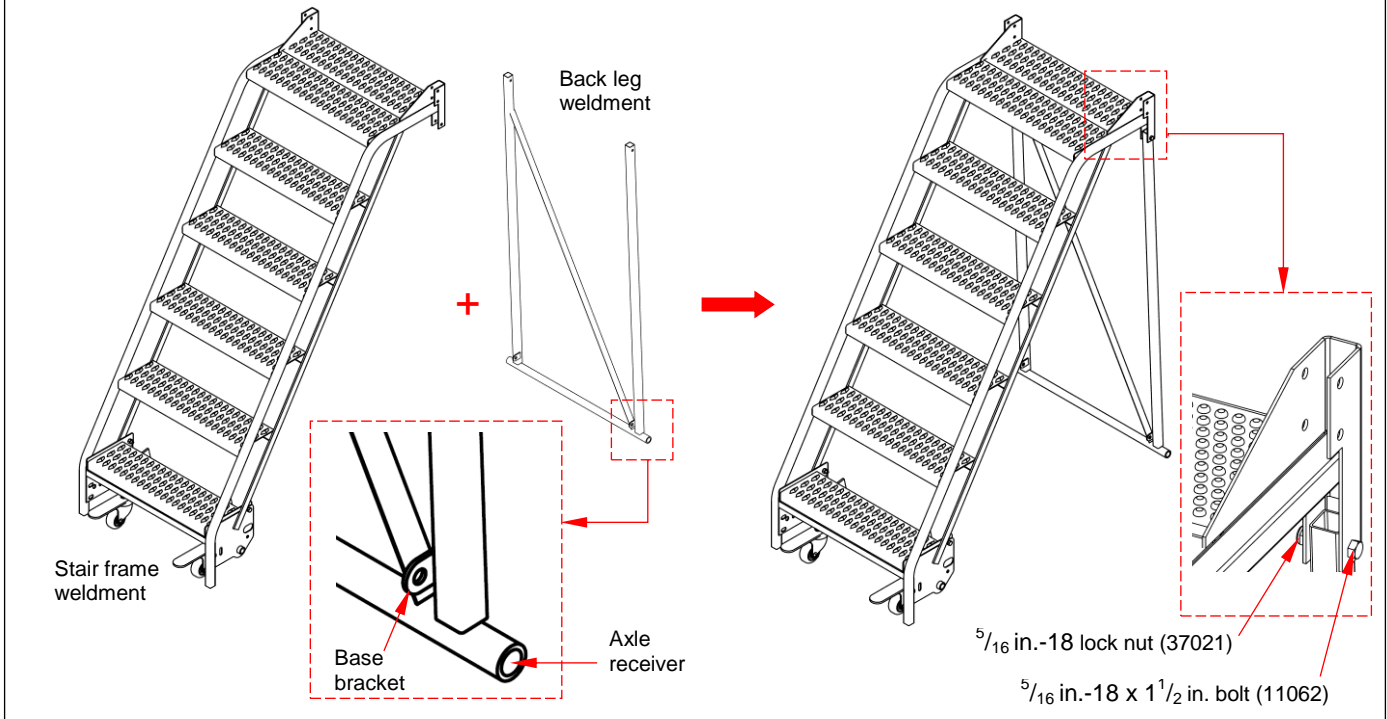

Step 3: Fasten the base supports to the ladder assembly with $\frac{5}{16}$ in. – 18 hardware as shown below.

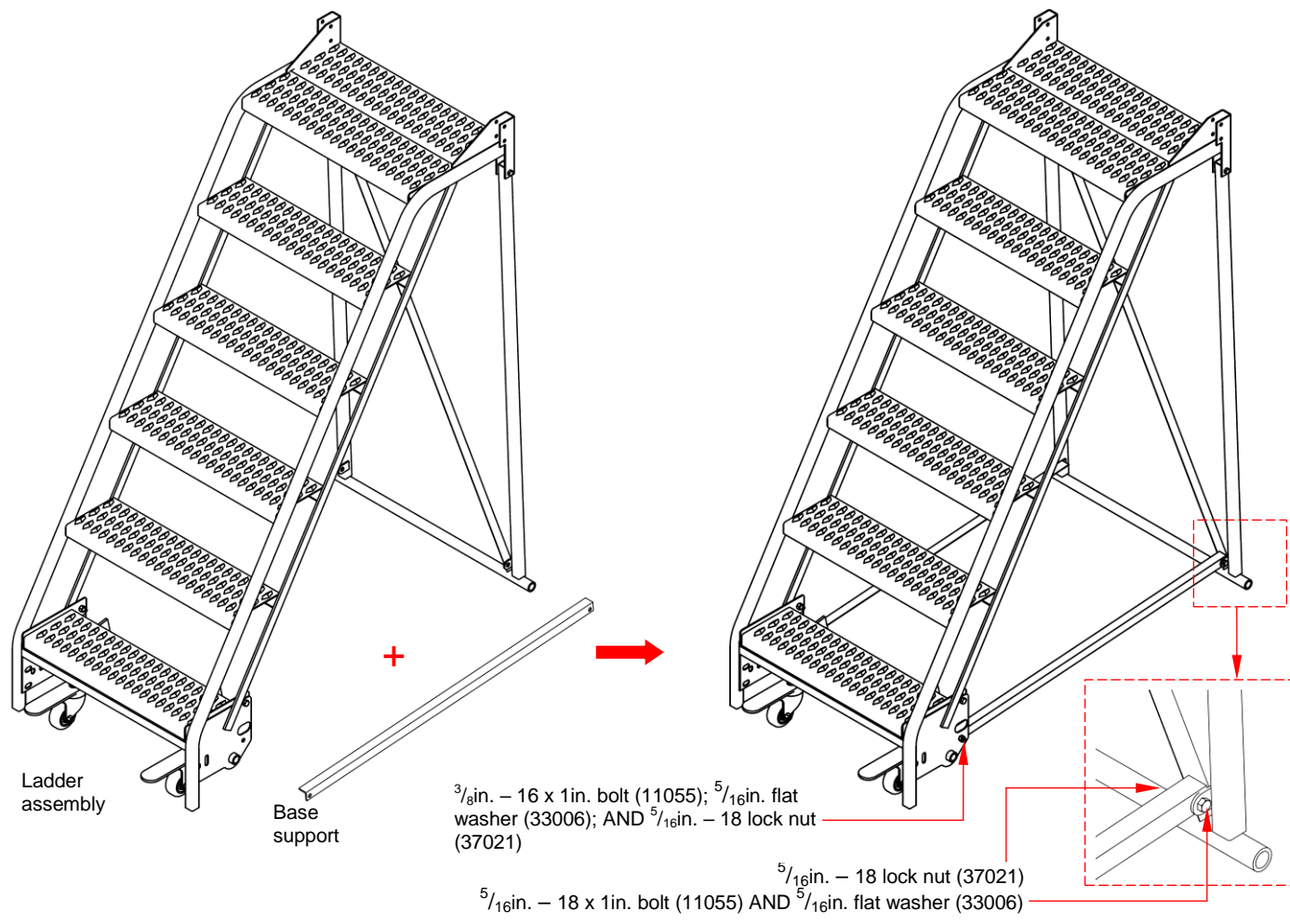

Step 4: Install the plugs, caps, axle and wheels.

- a) Install the plastic plugs and square caps in the front legs. First, press the 1 in. plastic plugs into the front legs. Then, press the square caps over the plugs and onto the ends of the legs. If necessary, use a rubber mallet to gently tap the plugs and caps into place.
- b) Insert the axle through the axle receiver of the back leg weldment.
- c) Then, slide the wheels onto the ends of the axle. Secure the wheels to the axle by inserting a cotter pin through the pinhole in each end of the axle. Periodically lubricate the axle to allow the wheels to rotate freely.

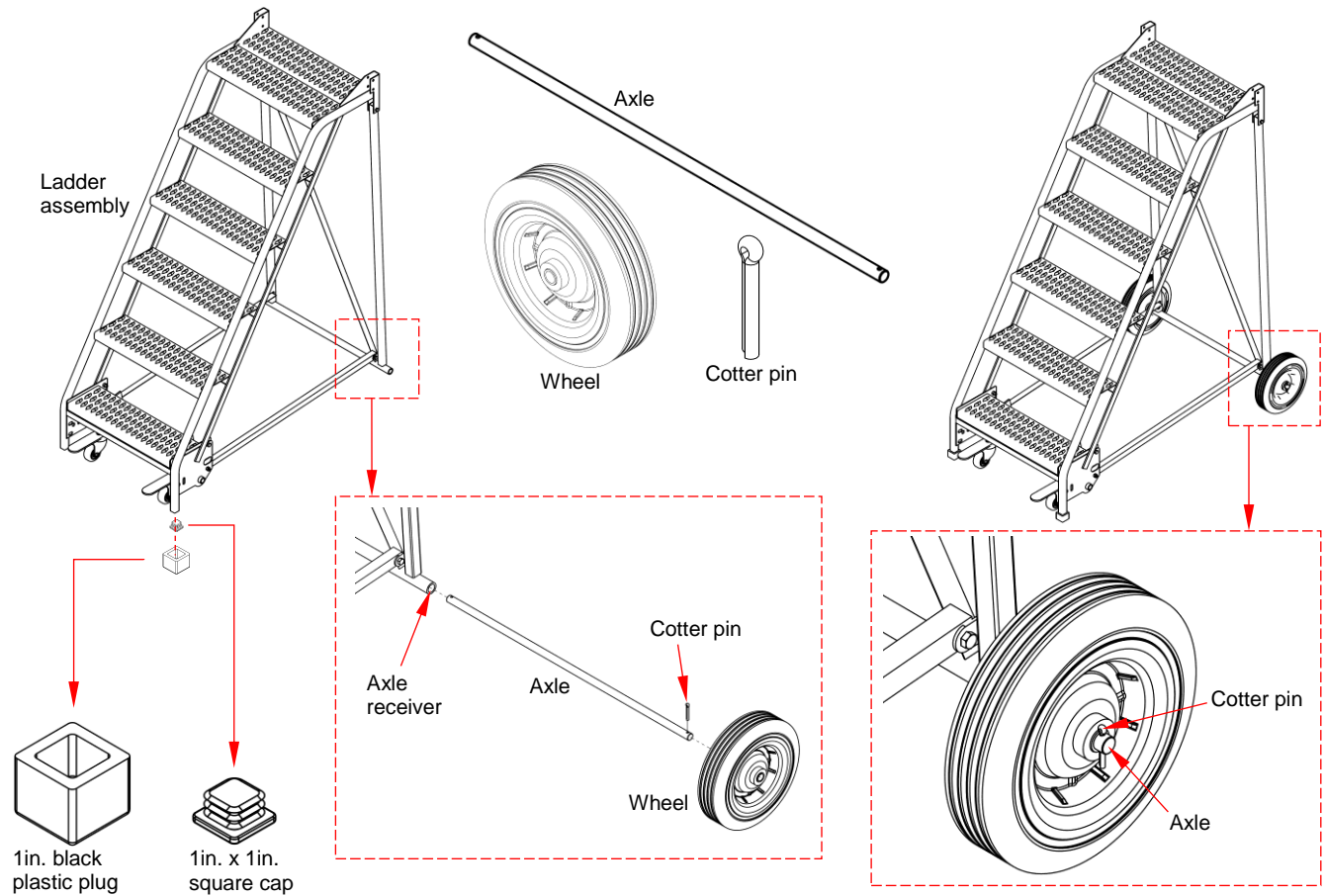

Step 5: Install the outriggers as diagrammed (11 and 12 step models only).

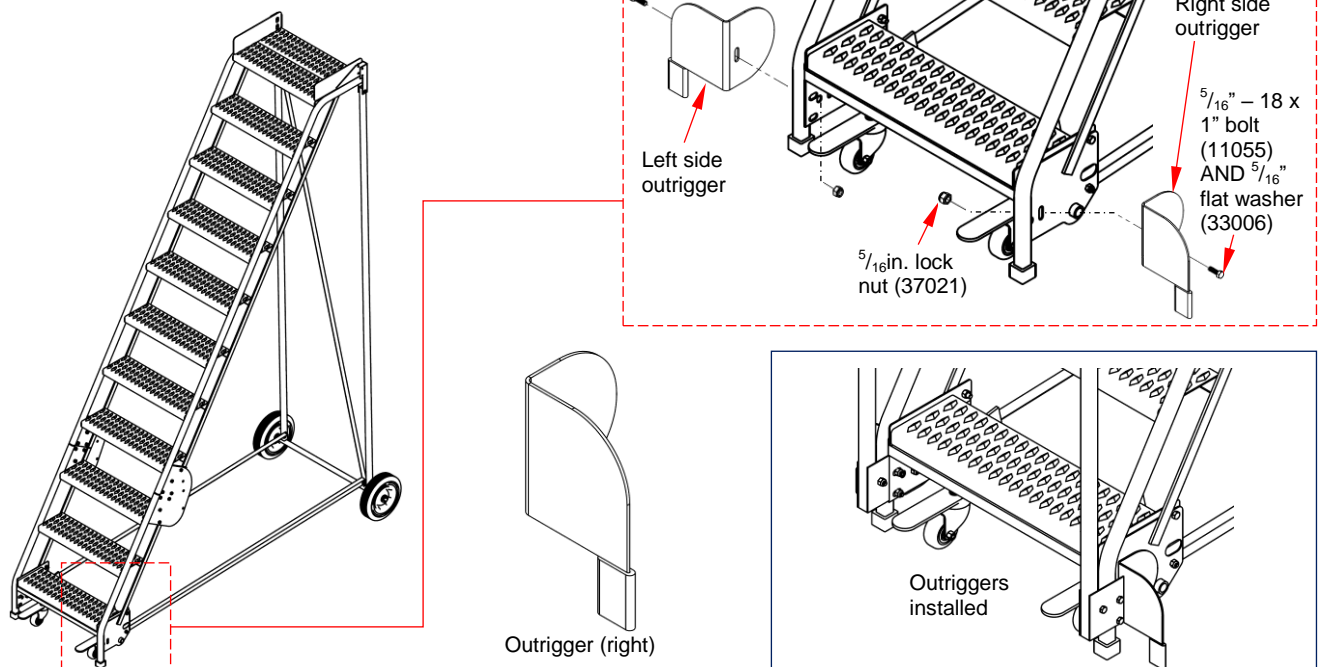

Step 6: Install the toeboard (11 & 12-step models only).

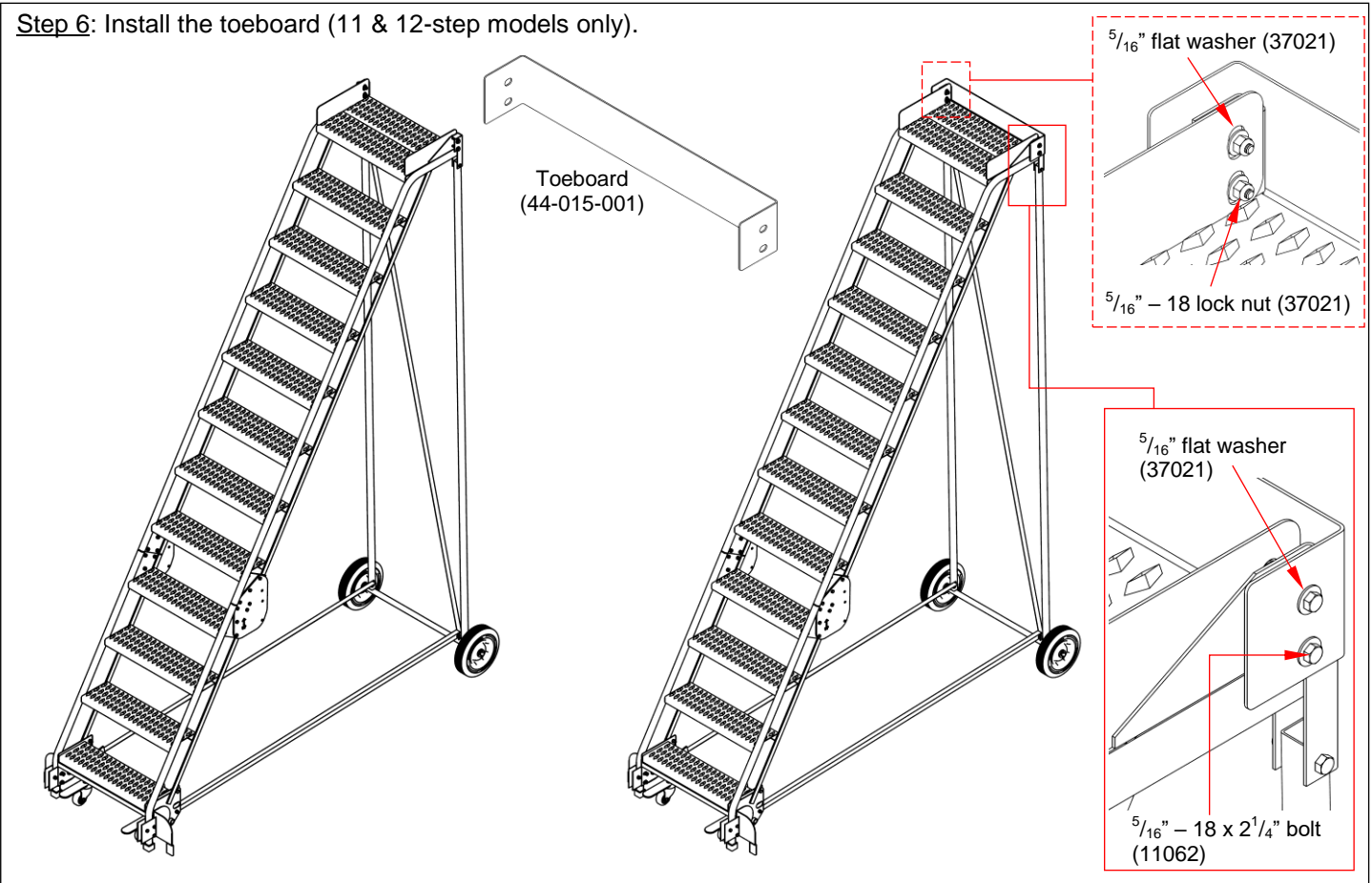

Step 7A: (10; 11 & 12 step models) fasten the upper and lower portions of the handrails to the ladder assembly.

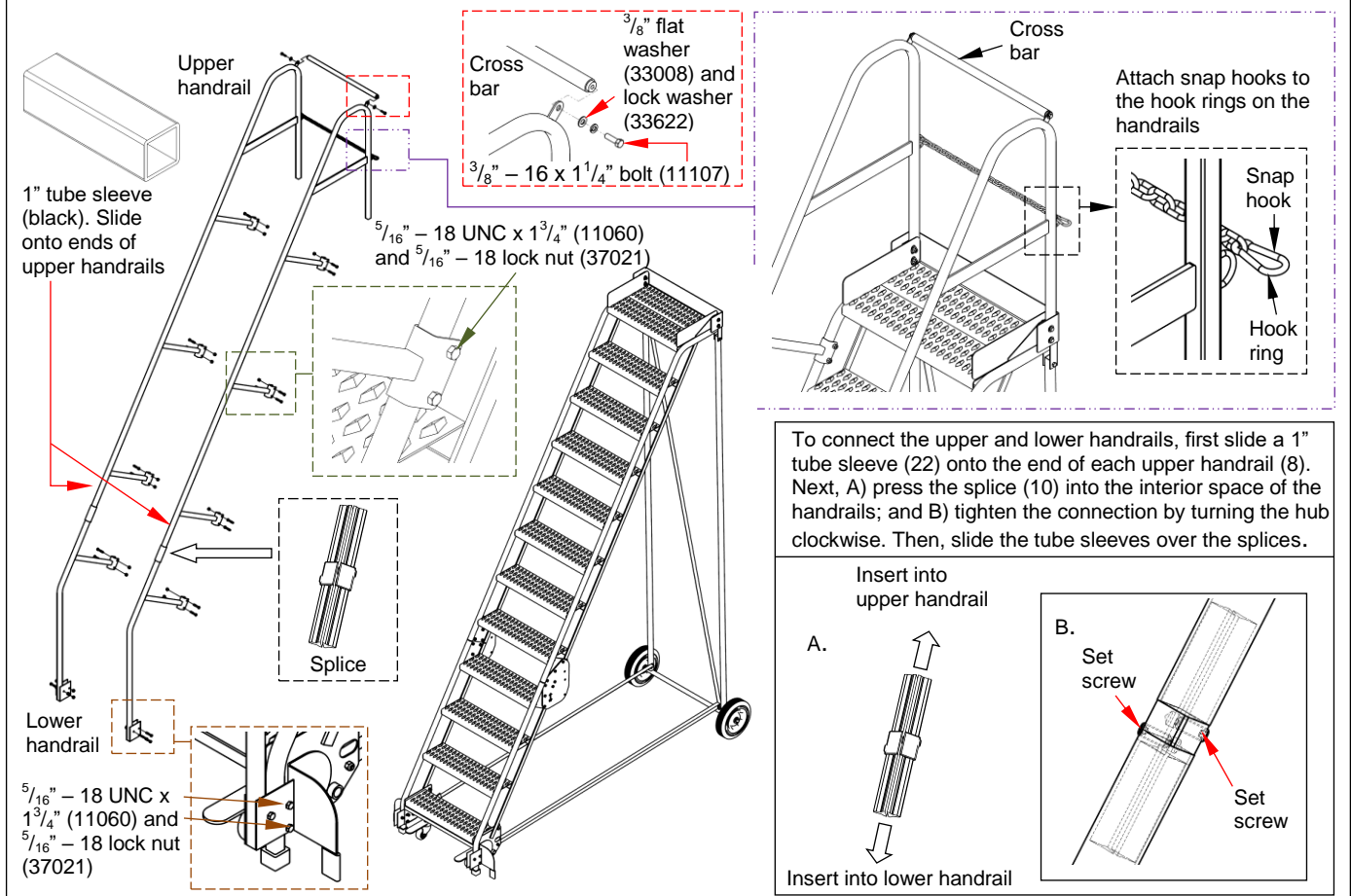

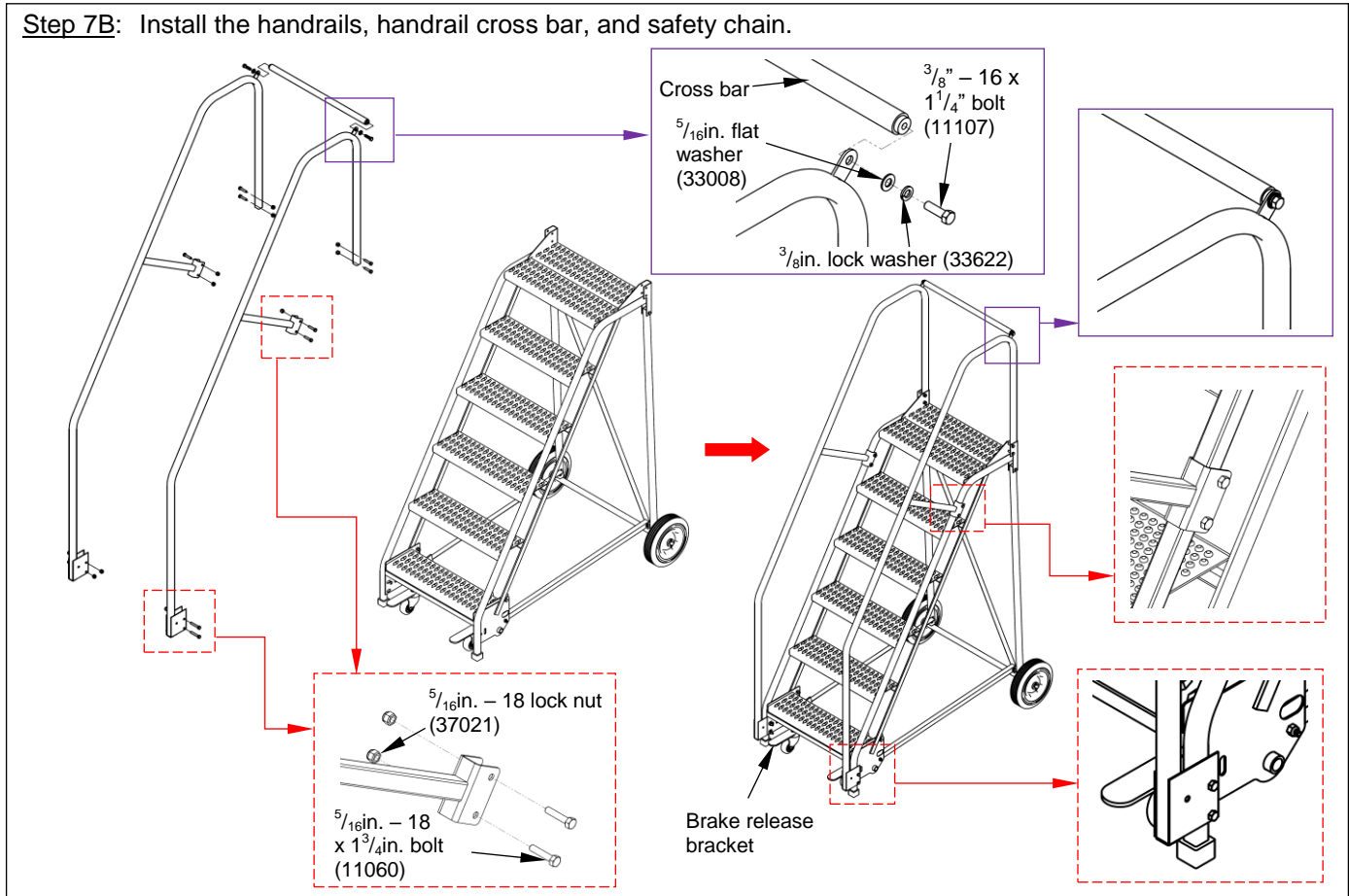

RECORD OF SATISFACTORY CONDITION (THE "RECORD")

After assembling the ladder and before putting it into service, visually inspect the ladder. Record the condition and appearance of each of the frame members (step weldment, back leg weldment, base support frame members), the handrails, outriggers, wheels and/or casters, (leg) caps, back platform frame and chain, and all fasteners (bolts, nuts, etc.). Thoroughly photograph the ladder from multiple angles. Include close range photographs of the rubber leg caps, casters and wheels, all labeling, and all handrail connections. Add the photographs to the record. Collate all photographs and writings into a single file. This file is a record of the ladder in satisfactory condition. Compare the results of all inspections to this Record to determine whether the ladder is in satisfactory condition. Do not use the ladder unless it is in satisfactory condition. Purely cosmetic changes, like damaged paint or powdercoat, are not changes from satisfactory condition. However, touchup paint should be applied as soon as damage occurs.

NATIONAL STANDARDS

This product is a "mobile ladder stand" (MLS). [ANSI standard A14.7](#) (the "Standard") applies to MLS's. You *should* acquire a copy of the latest version of the standard. Follow all use and maintenance/care instructions provided in the Standard as well as all other provisions for MLS owners and users. If any content in this manual conflicts with any mandatory provision(s) in the Standard, apply the provision(s) from the Standard. Vestil encourages you to immediately contact [Technical Service](#) if you discover any inconsistencies.

USING THE LADDER

Review the [SAFETY INSTRUCTIONS](#) on p. 2 before using the ladder.

Inspect the ladder before each use for damage, such as unusual wear, deterioration, or corrosion. Tighten loose nuts. If a lock nut has been partially or completely unfastened, it must be replaced with a new lock nut.

Make sure there are no children in the area where the ladder is used or stored.

Climbing the ladder:

ONLY use the ladder on even, level, improved surfaces (concrete or asphalt). Never use the ladder on angled surfaces. The ladder must not wobble or lean while in use. Only climb the ladder when the steps and handrails are clean and dry.

Stand on the bottom step. The front legs of the ladder should automatically lower into contact with the ground as the caster brackets pivot upwards (caster brackets identified on [p. 12](#)). The rubber caps on the front legs (see [Step 4](#)

on p. 15) must solidly contact the ground before climbing the ladder. The caps resist sliding movement. They are included to prevent the front end of the ladder from moving while they are in contact with the ground.

Face the ladder and grasp the handrails while ascending or descending the steps. Do not lean against the handrails, the guardrails (around the platform), or the platform bar or chain. Do not lean over the handrails or guardrails.

Moving the ladder:

After using the ladder, the mechanism that brings the front casters into ground contact must be reset. Lift the front of the ladder while pressing down on one of the caster brackets. Caster brackets are identified on p. 12.

Grasp the handrails and carefully push the ladder. Only try to move the ladder if you are able to comfortably lift the front end and can easily control the ladder.

Storing the ladder

This ladder is designed for use both indoors and outdoors. However, it should only be stored indoors. The ladder should be considered in storage whenever it has been unused for 30 minutes or more.

INSPECTIONS & MAINTENANCE

Inspect the unit as instructed. Inspections and all necessary repairs should be performed by qualified persons. Compare the results of each inspection to the [Record of Satisfactory Condition](#). Do not use the ladder unless every part is in satisfactory condition. If you have any questions about the condition of your ladder, contact the [Technical Service](#) department. The phone number is provided on the cover page of this manual. Never make temporary repairs of damaged or missing parts. Only use manufacturer-approved replacement parts to restore the ladder to satisfactory condition.

Before each use inspect the ladder for any sustained damage, such as unusual wear, deterioration, or corrosion. Look for loose connections. Tighten all loose connections. Whenever a lock nut is partially or completely unfastened, it must be replaced with a new lock nut. Check cotter pins at each end of the wheel axle, the wheels, and the square caps (99-024-027) for damage.

Regular inspections — at least once per month inspect the following items. Replace all parts not in satisfactory condition before returning the ladder to service. DO NOT continue to use the ladder if damage cannot be repaired.

- Handrails, guardrails, back frame weldment (platform bar), snap hooks, and platform chains: Confirm that both handrails are solidly fastened to the step weldment and to the platform. Each handrail should be straight, rigid, and undamaged. Examine the guardrails around the platform for damage, bends, and cracks. Examine the platform bar and, if applicable, the chain and snap hooks. Confirm that the bar and chain are undamaged and securely fastened to the guard railing. Snap hooks should close automatically.
- Rear wheels (16-132-310): Check the wheels. They must not be significantly worn, i.e. must still have ~1/8" of tread. Wheels must not be cracked, warped, broken, etc. They should be vertical (not bent towards, or away from, the ladder) and roll smoothly. Examine the wheel axle and cotter pins (11053) for damage.
- Frame members (step weldment, back leg weldment, base supports), handrails, and all fasteners (bolts, nuts, pins): Inspect each frame member for damage. In particular, look for excessive wear, bends, cracks, warps, damaged welds, and looseness. All frame pieces should be square, rigid, and free of rust and corrosion. Remove rust and apply touch-up paint to the affected area. Check the areas where components are fastened/bolted together. Check for cracks around bolt holes, elongated bolt holes, etc.
- Square caps (99-024-027): Check the caps for cracks, tears, and wear. If either cap is not in satisfactory condition, install a replacement cap before returning the ladder to service. Even a moderate amount of wear can affect the performance of a cap.
- [LAD-11 and LAD-12] Outriggers and outrigger fasteners (bolts, nuts): Examine the outriggers (44-514-310 & 44-514-311). Both should be undamaged and be securely fastened to the step weldment. Both outriggers should make solid contact with the ground. The ladder should not wobble. Confirm that the caps on the outrigger legs are in satisfactory condition.

Maintenance: Regular maintenance is required for the ladder to function properly for as long as possible. In addition to correcting issues discovered during inspections, maintain the ladder in the following ways.

- Clean the ladder with a damp cloth to remove dirt and grime, especially from step surfaces. Let the ladder dry completely before returning it to service.
- Lubricate bolts as necessary for the wheels to rotate freely.
- Apply touchup paint wherever the finish is damaged. Apply touchup paint as soon as damage occurs.

LABELING DIAGRAM

Each unit should be labeled as shown in the diagram. Label content and location are subject to change so your product might not be labeled exactly as shown. Compare the diagram below to your *Record of Satisfactory Condition*. If there are any differences between actual labeling and this diagram, contact *Technical Service*.

Replace all labels that are damaged, missing, or not easily readable (e.g. faded). To order replacement labels or to inquire whether your unit is properly labeled, contact the technical service and parts department online at <https://www.vestil.com/page-parts-request.php> or by calling (260) 665-7586 and asking for the Parts Department.

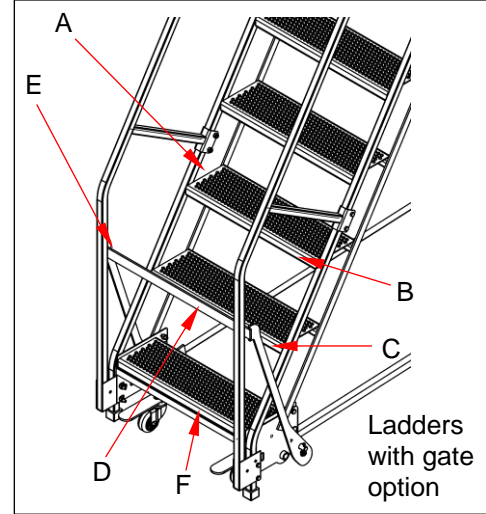
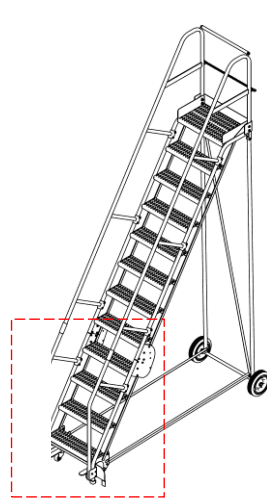
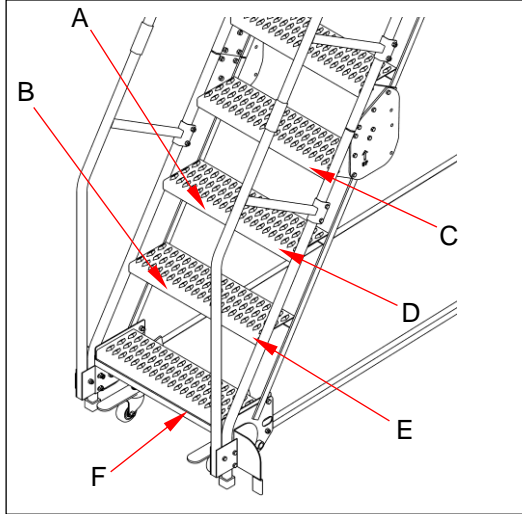

A: Label 821

SAFETY FIRST	SEGURIDAD PRIMERO
Read owners manual and all labels before using.	Lea el manual del propietario y todas las etiquetas antes del uso. 821

B: Label 287

MODEL/MODÉLO/MODÈLE _____
STATIC CAPACITY (evenly distributed) _____ lbs.
LA CAPACIDAD CONSTANTE (distribuida uniformemente) _____ kgs.
CAPACITÉ STATIQUE (distribuée régulièrement) _____ kgs.
SERIAL/SERIE/SÉRIE _____
287 REV 0812

C: Label 740

⚠ WARNING	⚠ ADVERTENCIA	⚠ AVERTISSEMENT
<ul style="list-style-type: none"> Do not use near live electric lines Do not climb rails or lean over rails Do not use if damaged or worn Use ladder on level, smooth surfaces only 	<ul style="list-style-type: none"> No use cerca de líneas eléctricas No se suba o se asome en la barandilla No use si esta danado o gastado Use la escalera en superficies a nivel y lisas 	<ul style="list-style-type: none"> Ne pas utiliser près des lignes électriques sous tension Ne pas grimper sur ou vous pencher des rails Ne pas utiliser si endommagée ou usagée Utiliser l'échelle seulement sur des surfaces plates et lisses
		740

D: Label 729

DANGER

**METAL CONDUCTS
ELECTRICITY!**

DO NOT CONTACT LIVE WIRES 729A

E: Label 468

AUTHORIZED PERSONNEL ONLY

468 REV 0812

F: Label 998

Step here to engage brake / Pise aqui para poner el freno

998

LIMITED WARRANTY

Vestil Manufacturing Company (“Vestil”) warrants this product to be free of defects in material and workmanship during the warranty period. Our warranty obligation is to provide a replacement for a defective, original part covered by the warranty after we receive a proper request from the Warrantee (you) for warranty service.

Who may request service?

Only a warrantee may request service. You are a warrantee if you purchased the product from Vestil or from an authorized distributor AND Vestil has been fully paid.

Definition of “original part”?

An original part is a part used to make the product as shipped to the Warrantee.

What is a “proper request”?

A request for warranty service is proper if Vestil receives: 1) a photocopy of the Customer Invoice that displays the shipping date; AND 2) a written request for warranty service including your name and phone number. Send requests by one of the following methods:

US Mail	Fax	Email
Vestil Manufacturing Company 2999 North Wayne Street, PO Box 507 Angola, IN 46703	(260) 665-1339 <u>Phone</u> (260) 665-7586	info@vestil.com Enter “Warranty service request” in subject field.

In the written request, list the parts believed to be defective and include the address where replacements should be delivered. After Vestil receives your request for warranty service, an authorized representative will contact you to determine whether your claim is covered by the warranty. Before providing warranty service, Vestil will require you to send the entire product, or just the defective part (or parts), to its facility in Angola, IN.

What is covered under the warranty?

The warranty covers defects in the following original, dynamic parts: motors, hydraulic pumps, motor controllers, and cylinders. It also covers defects in original parts that wear under normal usage conditions (“wearing parts”), such as bearings, hoses, wheels, seals, brushes, and batteries.

How long is the warranty period?

The warranty period for original dynamic components is 90 days. For wearing parts, the warranty period is 90 days. Both warranty periods begin on the date Vestil ships the product to the Warrantee. If the product was purchased from an authorized distributor, the periods begin when the distributor ships the product. Vestil may, at its sole discretion, extend a warranty period for products shipped from authorized distributors by up to 30 days to account for shipping time.

If a defective part is covered by the warranty, what will Vestil do to correct the problem?

Vestil will provide an appropriate replacement for any *covered* part. An authorized representative of Vestil will contact you to discuss your claim.

What is not covered by the warranty?

The Warrantee (you) is responsible for paying labor costs and freight costs to return the product to Vestil for warranty service.

Events that automatically void this Limited Warranty.

- Misuse;
- Negligent assembly, installation, operation or repair;
- Installation/use in corrosive environments;
- Inadequate or improper maintenance;
- Damage sustained during shipping;
- Collisions or other accidents that damage the product;
- Unauthorized modifications: Do not modify the product IN ANY WAY without first receiving written authorization from Vestil.

Do any other warranties apply to the product?

Vestil Manufacturing Corp. makes no other express warranties. All implied warranties are disclaimed to the extent allowed by law. Any implied warranty not disclaimed is limited in scope to the terms of this Limited Warranty. Vestil makes no warranty or representation that this product complies with any state or local design, performance, or safety code or standard. Noncompliance with any such code or standard is not a defect in material or workmanship.

