

# Operation Manual

## Hydraulic drum truck

MODEL: WA30A、WA30B

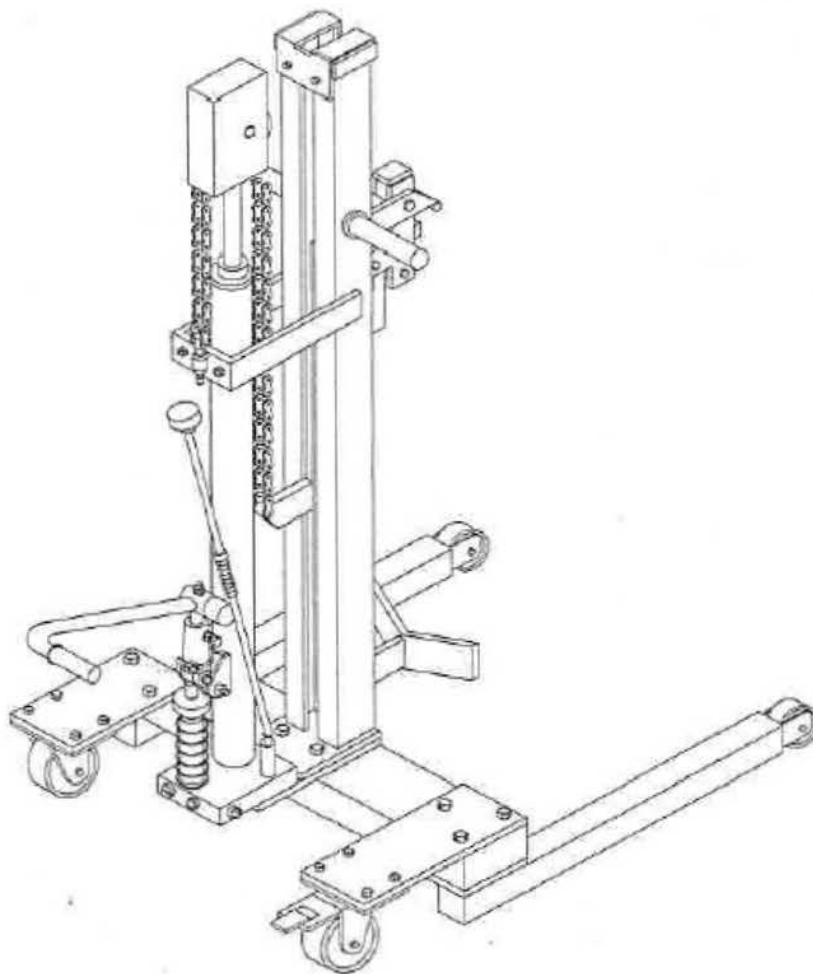

**Note:** The owner/operator must read carefully and understand all the information presented here before operation.

## Content

1	Specification.....	2
2	Part Name.....	4
3	Installation and Operation.....	4
4	Warning.....	5
5	Operation Instruction.....	5
	5.1 Lift drum.....	5
	5.2 Transport drum.....	6
	5.3 Put down drum.....	6
6	Hydraulic Circuit Diagram.....	7
7	Exploded View & Part List.....	8

THANK YOU FOR BUYING THE DT300/DT300L HYDRAULIC DRUM TRUCK. PLEASE READ THIS MANUAL CAREFULLY BEFORE USING THE TRUCK IN ORDER TO GET THE WAY OF OPERATING SAFELY AND MAINTAINING.

**NOTE:** All of the information reported herein is based on data available at the moment of printing. The factory reserves the right to modify its own products at any moment without notice and incurring in any sanction. So it is suggested to always verify possible updates.

This hydraulic drum truck can be used to load or unload, transport, stack the drum by clamping it. It is more suitable lifting the drum for its special design of low fork and high hoisting and is widely used in factories, warehouses and so on.

## 1. SPECIFICATION

Model		WA30B	WA30A
Suitable for Drum Diameter	(mm)	572	572
Capacity	(Kg)	300	300
Front Wheel Diameter	d (mm)	64	125
Rear Wheel Diameter	D (mm)	80	125
Minimum Clamp Height	H1(mm)	835	870
Maximum Clamp Height	H2(mm)	1640	1675
Total Height	H (mm)	1525	1560
Length	L (mm)	866	952
Width	W (mm)	956	956
Net Weight	(Kg)	68	72

# WA30B

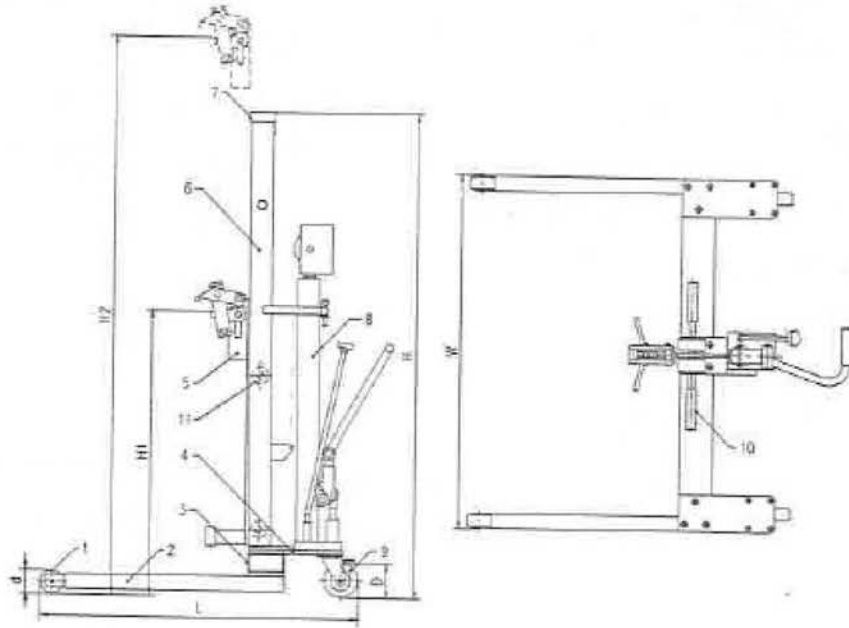

# WA30A

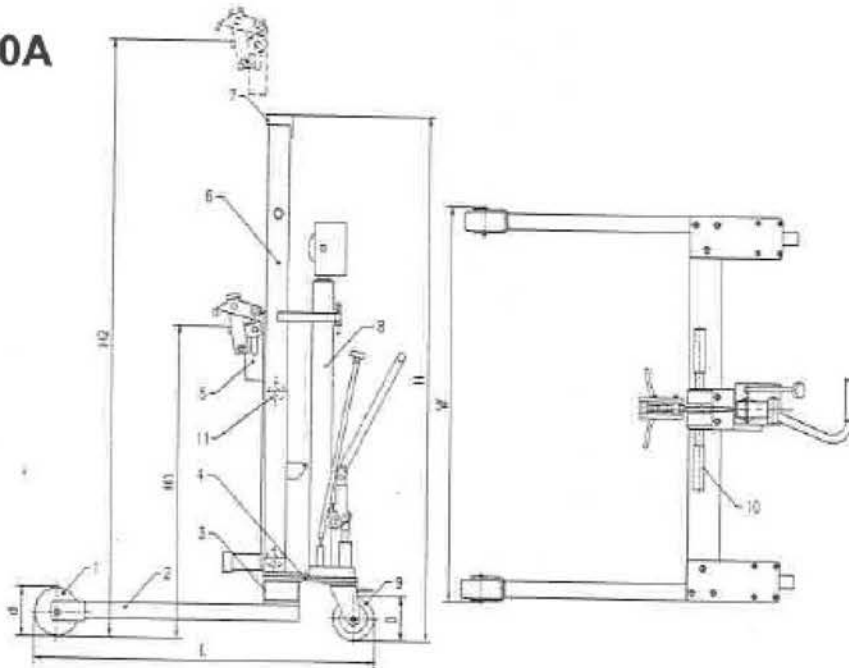

## 2. PART NAME

- |                                 |                                  |
|---------------------------------|----------------------------------|
| (1) Front Wheel                 | (7) Mast Bonnet                  |
| (2) Front Wheel Fork Assembly   | (8) Cylinder Assembly            |
| (3) Supporting Tube             | (9) Rear Wheel (Versatile Wheel) |
| (4) Rear Wheel Connecting Board | (10) Operation Handle            |
| (5) Supporting Clamp Structure  | (11) Pulley                      |
| (6) Mast Assembly               |                                  |

## 3. INSTALLATION

All the parts of the hydraulic drum truck have been cased up when finished. You can install it quickly and expediently as if following the steps below.

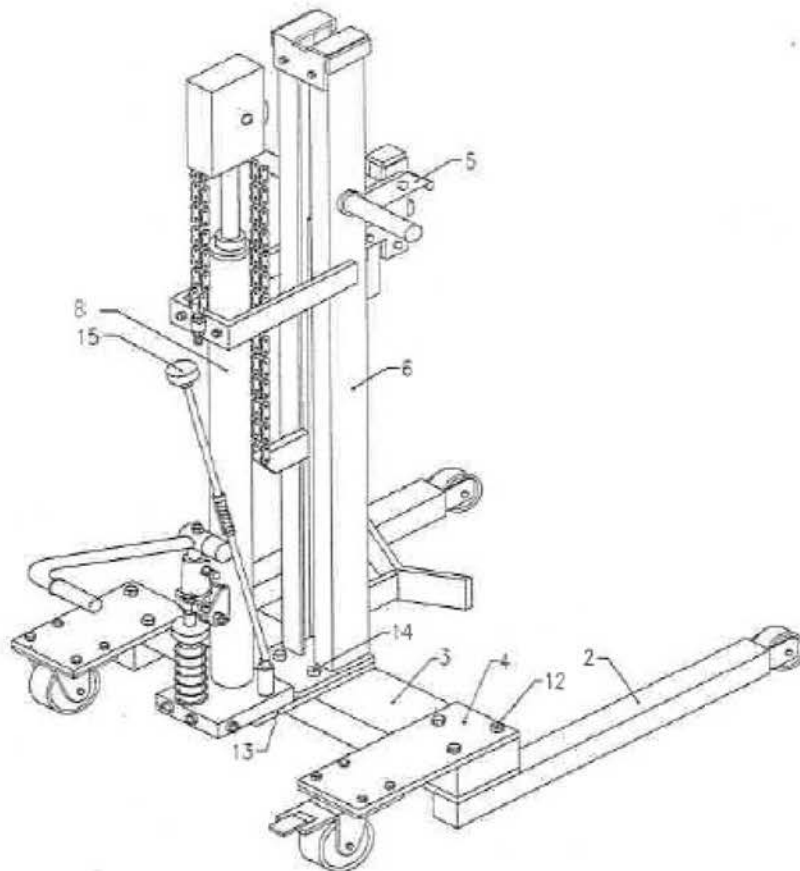

- 3.1 Make sure all of the parts are intact contained 2 (Front Wheel Fork Assembly), 12 (Connecting Bolt), 4 (Rear Wheel Connecting Board), 3 (Supporting Tube), 13 (Pad), 14 (Connecting bolt), 8 (Cylinder Assembly), 6 (Mast Assembly), 5(Supporting Clamp Structure).
- 3.2 Join 2 (Front Wheel Fork Assembly), 4 (Rear Wheel Connecting Board), 3 (Supporting Tube) together firmly with 12 (Connecting Bolt) as showed in picture.
- 3.3 Join 13 (Pad), 5.6.8(Mast & Supporting Clamp Assembly & Cylinder Assembly) and 3(Supporting Tube) together firmly with 14 (Connecting bolt).
- 3.4 Replace the screw plunge on the top of 8 (Cylinder Assembly) with (ventilated screw plunge).
- 3.5 Make sure supporting clamp structure lifts smoothly without load.
- 3.6 Make sure supporting clamp structure lifts smoothly, wheels move agilely, and brakes are available under the rated load.

#### **4. WARNING**

- 4.1 Never overload this truck beyond its rated capacity.
- 4.2 Place the drum in a low position when does not lift.
- 4.3 Raise the drum just away from the ground when transport it, do not need to lift it higher.

#### **5. OPERATION INSTRUCTION**

##### **5.1 Lift Drum**

Move the truck until its supporting clamp structure(5) touch the drum, tighten descending valve lever(15), kick the brake of rear wheel(9). Kick the pedal lever so that the upper biter of supporting clamp structure(5) will screw down to clamp the drum, then continue to kick the pedal lever to lift

the drum.

### 5.2 Transport drum

Loosen brake when the drum has been lifted, control operation handle(10) on the mast assembly(6) to transport the drum.(Just lift the drum a little when transporting it.)

### 5.3 Put down drum

Loosen descending valve lever(15) to descend the drum to the floor when reaching the destination, then the upper biter of supporting clamp structure(5) will loosen the drum. Tighten descending valve lever(15) at last.

**NOTE: It is forbidden to loosen descending valve lever (15) suddenly in case of danger.**

5.4 Please change the hydraulic oil if its work time adds up to 20 hours when you use it for the first time. After that, you should change the oil when its work time adds up to 300 hours. Change the oil every 18 months if the aggregate work time is deficient.

Use different hydraulic oil according to temperature scale below.

Temperature	Hydraulic Oil
-5℃—+45℃	L-HM68 Hydraulic Oil (equivalent to ISO VG68)
-15℃—-5℃	L-HM46 Hydraulic Oil (equivalent to ISO VG46)

**Put mast plunge rod at the bottom position when changing the oil. Keep adding the oil until the level reaches the oil hole.**

## 6. HYDRAULIC CIRCUIT DIAGRAM

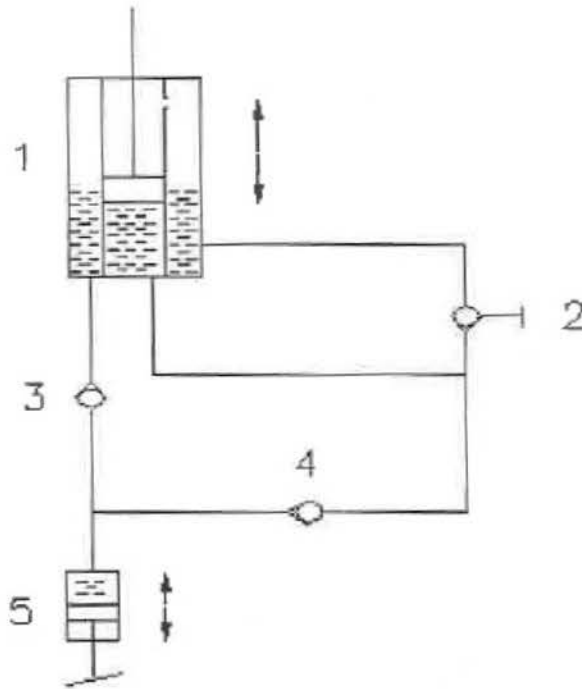

No.	Description
1	Hydraulic Cylinder
2	Swivel Discharge Valve
3	Relief valve
4	Work valve
5	Work Cylinder



## 7. EXPLODED VIEW & PART LIST

### 7.1 Exploded View

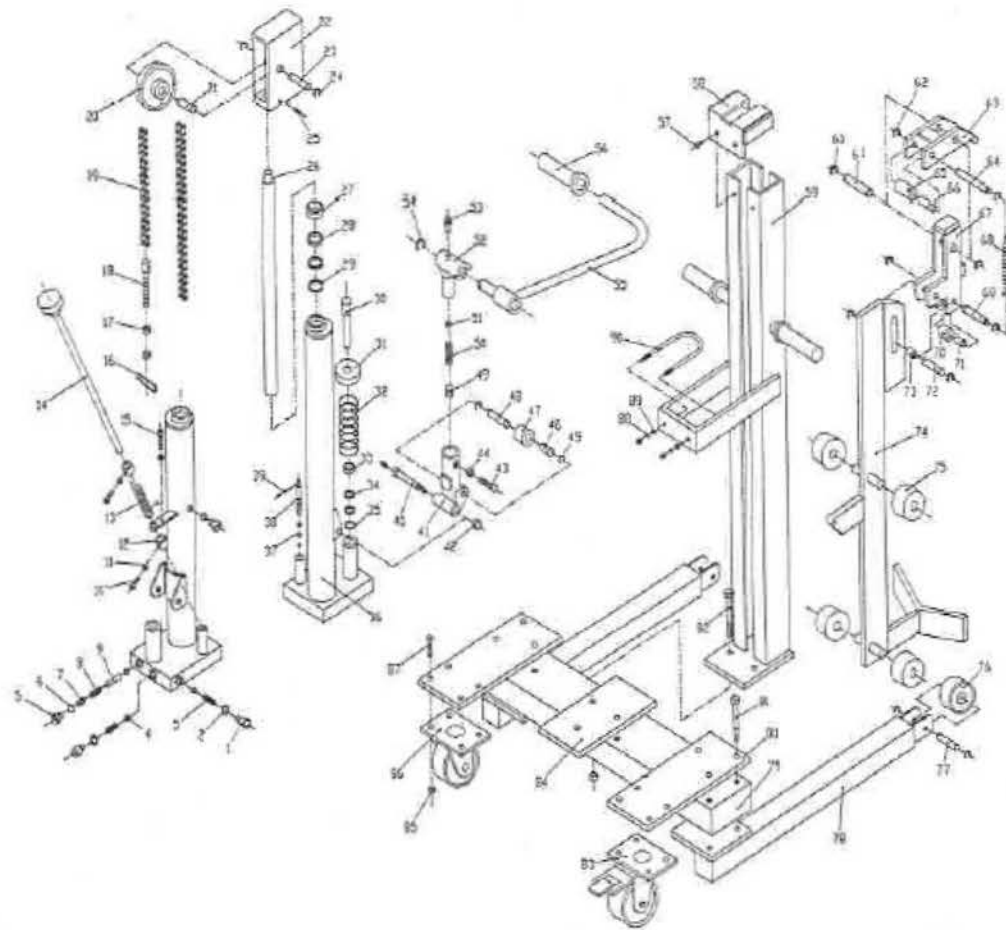

## 7.2 Part List

No.	Description	Qty	No.	Description	Qty
1	Inside hex screw	2	23	Chain pin axle	1
2	Copper washer	2	24	Split ring	6
3	Taper spring	2	25	Adjusting screw	1
4	Steal ball	4	26	Plunger rod	1
5	Screw plunger	2	27	Dustproof ring	1
6	O-ring	2	28	O-ring	2
7	Locking screw	1	29	Nylon washer	1
8	Spring	1	30	Pump rod	1
9	Short pin	1	31	Pump cover	1
10	Inside hex screw	2	32	Pump ring	1
11	Hex nut	4	33	Dustproof ring	1
12	Locating ring	2	34	O-ring	2
13	Torsional spring	1	35	Nylon washer	1
14	Unitary valve rod	1	36	Welding the fule tank body	1
15	Inside hex screw	1	37	O-ring	2
16	Split pin	1	38	Valve core	1
17	Hex nut	4	39	Spring pin	1
18	Chain bolt	1	40	Pin axle	1
19	Roller chain	1	41	Seat	1
20	Chain wheel	1	42	Nut	1
21	Bearing	2	43	Hex bolt	1
22	Chain cover	1	44	Hex nut	1

No.	Description	Qty	No.	Description	Qty
45	Split ring	2	67	Nether Clamp Assembly	1
46	Bearing	1	68	Spring	1
47	Ring	1	69	Pin Axle	1
48	Pin axle	1	70	Pulley	1
49	Adjusting screw	1	71	Bearing	1
50	Spring	1	72	Bushing	1
51	Steel ball	1	73	Pin Axle	1
52	Sheath	1	74	SupportingStructure Assembly	1
53	Oil cup	2	75	Pulley	4
54	Split ring	1	76	FrontWheelΦ64(WA30B)	2
55	Lever	1		FrontWheelΦ125(WA30A)	2
56	Rubber sheath	3	77	Front Wheel Pin Axle	2
57	Hex Bolt	2	78	Front Wheel Fork Assembly	2
58	Mast Bonnet	1	79	Supporting Tube	1
59	Mast Assembly	1	80	Rear Wheel Connecting Board	2
60	Axle Fender Ring	2	81	Hex Bolt	6
61	Pin Axle	1	82	Hex Bolt	2
62	Axle Fender Ring	6	83	versatile WheelΦ80 (WA30B)	1
63	Upper Clamp Assembly	1		versatileWheelΦ125(WA30A)	1
64	Pin Axle	1	84	Pad	1
65	Pulley	1	85	Hex nut	8
66	Bearing	1			

No.	Description	Qty	No.	Description	Qty
86	Rear Wheel $\Phi$ 80 (WA30B)	1	88	Spring washer	2
	Rear Wheel $\Phi$ 125(WA30A)	1	89	Washer	2
87	Hex Bolt	8	90	U hoop	1