



**VESTIL MANUFACTURING CORP.**  
 2999 North Wayne Street, P.O. Box 507, Angola, IN 46703  
 Telephone: (260) 665-7586 -or- Toll Free (800) 348-0868  
 Fax: (260) 665-1339  
 www.vestilmfg.com e-mail: [info@vestil.com](mailto:info@vestil.com)

## PLBS-Series Wheeled, Steel Pry Bars Instruction Manual



**Receiving instructions:**

After delivery, remove the packaging from the product. Inspect the product closely to determine whether it sustained damage during transport. If damage is discovered, record a complete description of it on the bill of lading. If the product is undamaged, discard the packaging.

**NOTE:**

The end-user is solely responsible for confirming that product design, installation, use, and maintenance comply with laws, regulations, codes, and mandatory standards applied where the product is used.

**Table of Contents:**

Signal Words.....	2
Safe Use Recommendations.....	2
Product Specifications.....	2
Labeling Diagram.....	4
PLBS exploded parts diagram & bill of materials.....	3
Use instructions.....	3
Inspections.....	3
Maintenance.....	3
Limited Warranty.....	4

## Signal Words

Within this manual, SIGNAL WORDS are used to indicate the likelihood of personal injuries, as well as the probable seriousness of those injuries, if the product is misused in the ways described. The signal word “NOTICE” identifies uses of the product that are likely to cause property damage.



Identifies a hazardous situation which, if not avoided, **WILL** result in **DEATH** or **SERIOUS INJURY**. Use of this signal word is limited to the most extreme situations.



Identifies a hazardous situation which, if not avoided, **COULD** result in **DEATH** or **SERIOUS INJURY**.



Indicates a hazardous situation which, if not avoided, **COULD** result in **MINOR** or **MODERATE** injury.



Identifies practices likely to result in product/property damage, such as operation that might damage the product.

## Safe Use Recommendations:

Vestil strives to identify the foreseeable hazards of using its products. However, material handling is inherently dangerous and no manual can address every conceivable risk. Ultimately, the most effective way to avoid causing injuries is for the operator to exercise sound judgment whenever this device is used.



Improper use could result in serious personal injuries.

- *Failure to read and understand the entire manual before assembling, using or servicing the pry bar is a misuse of the product.* Read the manual to refresh your understanding of proper use and maintenance procedures.
- DO NOT exceed the maximum rated load (see Label 287 on product; also shown on p. 4).
- Only use the pry bar on improved surfaces (concrete or asphalt).
- DO NOT apply more than 150 lb. downward force on the end of the pry bar handle.
- DO NOT hang on, sit on, or bounce on the pry bar while attempting to tip or hold a load.
- ALWAYS carefully watch the load on the pry bar.
- Inspect the pry bar before each use (see “Inspections” & “Maintenance” sections on p. 3). DO NOT use the device unless it is in satisfactory condition.
- DO NOT use the pry bar to transport loads. Only use the bar to lift an edge or a corner of a load.
- DO NOT lean over the pry bar while using it to lift a load.
- DO NOT use the pry bar if it is damaged.
- DO NOT modify the pry bar in any way. Modifications automatically void the limited warranty (see p. 4) and might make the product unsafe to use.

## Product Specifications:

Model	Description	Bar Length	Caster Dimensions	Caster Type	Maximum Rated Load	Net Weight
PLBS-5	Steel pry bar	5 ft.	5in. x 2in.	Poly-on-steel	5,000 lb. 2272.7 kg	41 lb. 18.6 kg
PLBS-6	Steel pry bar	6 ft.	5in. x 2in.	Poly-on-steel	5,000 lb. 2272.7 kg	43 lb. 19.5 kg
PLBS-7	Steel pry bar	7 ft.	5in. x 2in.	Poly-on-steel	5,000 lb. 2272.7 kg	45 lb. 20.3 kg

## Labeling Diagram:

The product should always be labeled as shown in the diagram below. Replace any label that is damaged or not easily readable.



Label 287: Model, serial no., capacity  
(applied to back side of plate)

MODEL/MODÉLO/MODELE	_____
STATIC CAPACITY (evenly distributed)	_____ lbs.
LA CAPACIDAD CONSTANTE (distribuida uniformemente)	_____ kgs.
CAPACITÉ STATIQUE (distribuée régulièrement)	_____ kgs.
SERIAL/SERIE/SÉRIE	_____

287 REV 0812

Exploded parts diagram and bill of materials

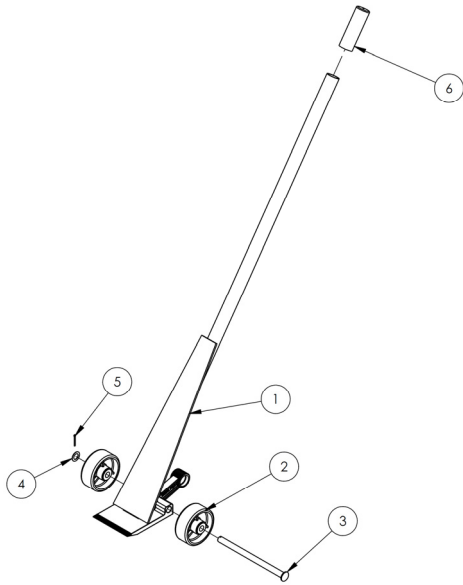

Item no.	Part no.	Description	Quantity
1	33-514-004	Frame weldment	1
	33-514-005	PLBS-5	1
	33-514-006	PLBS-6	1
		PLBS-7	1
2	16-132-020-001	5" x 2" poly on steel wheel, roller bearing, for 3/4" axle	2
3	33-112-013	Axle pin	1
4	33424	Machine bushing, low carbon, plain finish, 3/4" x 18ga.	1
5	65058	1/64" x 1 1/2" zinc-plated cotter pin	1
6	13-025-015	Handle grip	1
*	13-154-006	Replacement parts: complete wheel kit	

**Use instructions:**

To lift an object with the pry bar:

1. Slide the nose plate under the object. If necessary apply steady pressure to the foot lever to push the plate under the object; then
2. Carefully pull down the end of the handle. Make sure that the nose plate does not slip out from under the object.

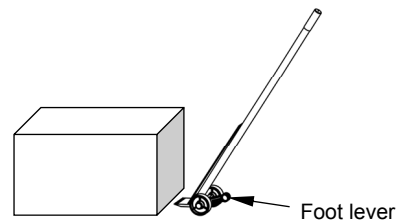

**Inspections & Maintenance:** perform the inspections explained below and maintain the pry bar as described to ensure that the unit is in normal, safe operating condition.

**⚠WARNING** If a problem is discovered during an inspection, restore the unit to normal operating condition BEFORE using it again.

**Inspections:**

Before each use (including first use) inspect:

1. Handle and nose plate: look for regions of significant wear, cracks, cracked welds, deformity, corrosion, & rust.
2. Wheels and mounting hardware: roll the pry bar to confirm that the wheels and bearings are in normal condition. Examine the axle pin, machine bushing and cotter pin. The axle pin should be straight and undamaged. The bushing should be undamaged and allow the wheel it contacts to turn smoothly without contacting the cotter pin. The cotter pin should be undamaged and securely attached to the axle pin.
3. Product labels: all labels should be readable and located as shown in the "Label placement diagram" on p. 4. If a label(s) is unreadable or missing, contact Vestil to order a replacement.

**Maintenance:**

**⚠WARNING** DO NOT use the unit if repairs are incomplete! While servicing the pry bar, DO NOT modify it in any way. A "modification" is a change that alters the product from original condition, like bending the structural members or removing a part or several parts. Modifications might make the device unsafe to use and *automatically* void the limited warranty.

**NOTICE** Proper use, maintenance, and storage are essential for this product to function properly.

- Always use the pry bar as described in this instruction manual.
- ONLY install replacement parts supplied or approved by the manufacturer.
- ALWAYS store the pry bar in a dry location.

Step 1: Remove any dirt or other matter from all surfaces.

Step 2: Inspect the pry bar as suggested on p. 3. If deformity, corrosion, rusting, or excessive wear is discovered, DO NOT use the product.

Step 3: Perform all necessary adjustments, replacements and/or repairs.

Step 4: Make a dated record of all repairs, adjustments and/or replacements.

## LIMITED WARRANTY

Vestil Manufacturing Corporation (“Vestil”) warrants this product to be free of defects in material and workmanship during the warranty period. *Our warranty obligation is to provide a replacement for a defective original part if the part is covered by the warranty, after we receive a proper request from the warrantee (you) for warranty service.*

### Who may request service?

Only a warrantee may request service. *You are a warrantee if* you purchased the product from Vestil or from an authorized distributor AND Vestil has been fully paid.

### What is an “original part”?

An original part is a part used to make the product as shipped to the warrantee.

### What is a “proper request”?

A request for warranty service is proper if Vestil receives: 1) a photocopy of the Customer Invoice that displays the shipping date; AND 2) a written request for warranty service including your name and phone number. Send requests by any of the following methods:

<u>Mail</u>	<u>Fax</u>	<u>Email</u>
Vestil Manufacturing Corporation 2999 North Wayne Street, PO Box 507 Angola, IN 46703	(260) 665-1339 <u>Phone</u> (260) 665-7586	sales@vestil.com

In the written request, list the parts believed to be defective and include the address where replacements should be delivered.

### What is covered under the warranty?

After Vestil receives your request for warranty service, an authorized representative will contact you to determine whether your claim is covered by the warranty. Before providing warranty service, Vestil may require you to send the entire product, or just the defective part or parts, to its facility in Angola, IN. The warranty covers defects in the following *original* dynamic components: motors, hydraulic pumps, electronic controllers, switches and cylinders. It also covers defects in *original* parts that wear under normal usage conditions (“wearing parts”): bearings, hoses, wheels, seals, brushes, batteries, and the battery charger.

### How long is the warranty period?

The warranty period for original dynamic components is 90 days. For wearing parts, the warranty period is 90 days. The warranty periods begin on the date when Vestil ships the product to the warrantee. If the product was purchased from an authorized distributor, the periods begin when the distributor ships the product. Vestil may, at its sole discretion, extend the warranty periods for products shipped from authorized distributors by *up to* 30 days to account for shipping time.

### If a defective part is covered by the warranty, what will Vestil do to correct the problem?

Vestil will provide an appropriate replacement for any *covered* part. An authorized representative of Vestil will contact you to discuss your claim.

### What is not covered by the warranty?

1. Labor;
2. Freight;
3. Occurrence of any of the following, which automatically voids the warranty:
  - Product misuse;
  - Negligent operation or repair;
  - Corrosion or use in corrosive environments;
  - Inadequate or improper maintenance;
  - Damage sustained during shipping;
  - Collisions or other incidental contacts causing damage to the product;
  - Unauthorized modifications: DO NOT modify the product IN ANY WAY without first receiving written authorization from Vestil. Modification(s) might make the product unsafe to use or might cause excessive and/or abnormal wear.

### Do any other warranties apply to the product?

Vestil Manufacturing Corp. makes no other express warranties. All implied warranties are disclaimed to the extent allowed by law. Any implied warranty not disclaimed is limited in scope to the terms of this Limited Warranty.

