

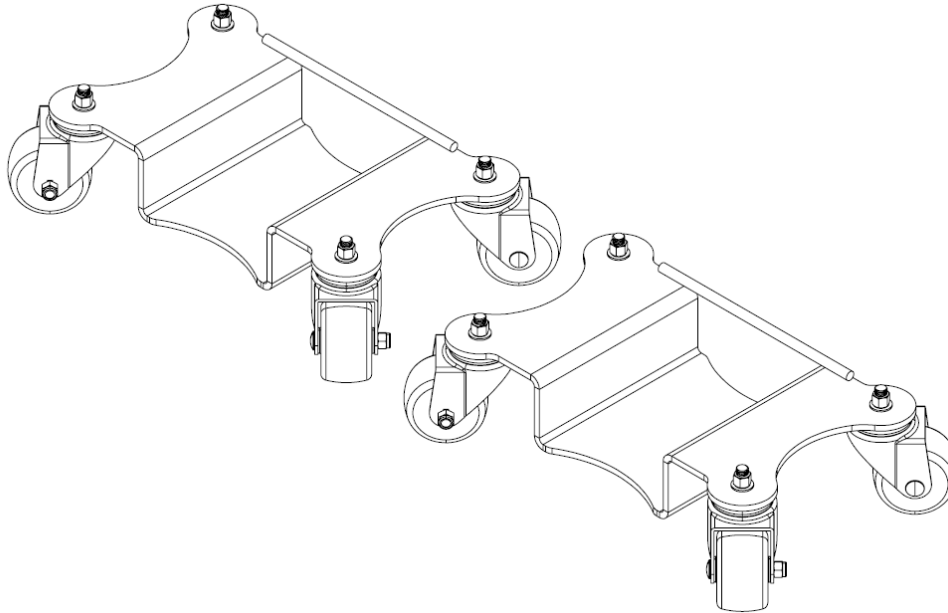

Vestil Manufacturing Corp.
 2999 North Wayne Street, P.O. Box 507, Angola, IN 46703
 Telephone: (260) 665-7586 -or- Toll Free (800) 348-0868
 Fax: (260) 665-1339
 Web: www.vestilmfg.com e-mail: info@vestil.com

PRRJ-DOL



Receiving Instructions

After delivery, remove the packaging from the product. Inspect the product closely to determine whether it sustained damage during transport. If damage is discovered, record a complete description of it on the bill of lading. If the product is undamaged, discard the packaging.

NOTE: The end-user is solely responsible for confirming that product design, use, and maintenance comply with laws, regulations, codes, and mandatory standards applied where the product is used.

Technical Service & Replacement Parts

For answers to questions not addressed in these instructions and to order replacement parts, labels, and accessories, call our Technical Service and Parts Department at (260) 665-7586. The Department can also be contacted online at <https://www.vestil.com/page-parts-request.php>.

Electronic Copies of Instruction Manuals

Additional copies of this instruction manual may be downloaded from <https://www.vestil.com/page-manuals.php>.

Table of Contents		Page
Signal Words		2
Safety Instructions		2
Using the Product		3
Exploded View and Bill of Materials		3
Record of Satisfactory Condition		4
Inspections & Maintenance		4
Labeling Diagram		4
Limited Warranty		5

SIGNAL WORDS

This manual uses SIGNAL WORDS to indicate the likelihood that a particular action will cause personal injuries or property damage. Signal words also specify the level of seriousness of injury if the product is misused in the ways described. The following signal words are used in this manual.



Identifies a hazardous situation which, if not avoided, WILL result in DEATH or SERIOUS INJURY. Use of this signal word is limited to the most extreme situations.



Identifies a hazardous situation which, if not avoided, COULD result in DEATH or SERIOUS INJURY.



Indicates a hazardous situation which, if not avoided, COULD result in MINOR or MODERATE injury.



Identifies practices likely to result in product/property damage, such as operation that might damage the product.

SAFETY INSTRUCTIONS

Vestil strives to identify all foreseeable hazards associated with the use of its products. Material handling is dangerous and no manual can address every conceivable risk. Ultimately, the most effective way to prevent injury is to apply sound judgment whenever using this device.



Improper or careless use of this product could result in death or serious personal injuries.

- *Read and understand the entire manual before assembling, installing, using or servicing the product.* Read the manual to refresh your understanding of proper use and maintenance procedures.
- DO NOT attempt to resolve any problem(s) with the product unless you are qualified to perform maintenance.
- DO NOT modify the product in any way UNLESS you first obtain written approval from Vestil. Unapproved modifications automatically void the **LIMITED WARRANTY** and might make the product unsafe to use.
- DO NOT exceed the capacity: 500 pounds (227 kg) per dolly. Capacity information is provided in on-product labeling. See Label 1153 in the **LABELING DIAGRAM** on p. 4.
- Inspect the product according to the instructions in **INSPECTIONS & MAINTENANCE**. DO NOT use the product unless it is in **SATISFACTORY CONDITION**.
- DO NOT use this device UNLESS all product labels are in place, easily readable, and undamaged. See **LABELING DIAGRAM**.



Proper use, maintenance, and storage are essential for this product to function properly.

- Always use this product in accordance with the instructions in this manual and consistent with any training relevant to machines, devices, etc. used in conjunction with this product.
- Keep the product clean & dry. Lubricate moving parts.

USING THE PRODUCT

PRRJ-series skates/dollies should only be used to transport assembled pallet racks that satisfy the following requirements:

- Rack is completely unloaded
- Rack length does not exceed 12ft (3.6m)
- All necessary rack braces are securely fastened to adjacent rack uprights (rack must be rigidly fastened together; unable to bend, flex, or twist)
 - Uprights include cross braces and lowermost cross braces are not less than 4in. (10cm) above ground level

Additional requirements include:

- Ground surface must be smooth and clean (free of debris)
- Ground surface must be level and even
- Strongly recommended that 4 persons participate in each move (1 at each corner); 2 persons minimum (1 at each end)

EXPLODED VIEW AND BILL OF MATERIALS (16-006-271)

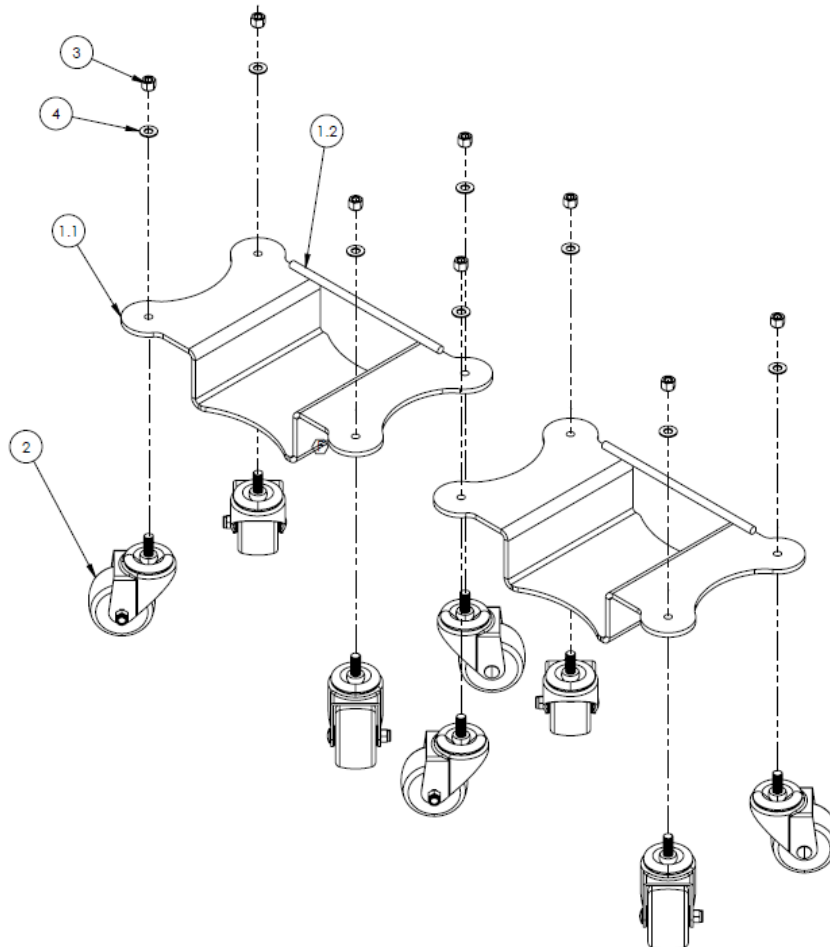

ITEM NO.	PART NO.	DESCRIPTION	QTY.
1	16-514-178	FRAME WELDMENT	1
1.1	16-014-604	FRAME, CENTER	1
1.2	16-017-094	BAR, STIFFENER	1
2	16-132-164-601	CASTER, 3" STEM SWIVEL	8
3	37024	NYLON INSERT LOCK NUT, GRADE 2, ZINC FINISH, 3/8"-16	8
4	33082	WASHER, 3/8" ZINC PTD, SAE FLAT WASHER	8

RECORD OF SATISFACTORY CONDITION (THE “RECORD”)

Make a detailed record of the condition of each skate/dolly. Include observations about all features: welds, frame elements, fasteners (bolts, nuts, washers, etc.) and casters/wheels. Thoroughly photograph the unit from multiple angles so that all features are clearly imaged. Photograph all labels applied to the product. Describe where each label is located. Collect all photographs and writings in a single file. This file is a record of the product in satisfactory condition. Compare the results of each inspection to this *RECORD* to determine if the unit is in satisfactory condition. Do not use a dolly unless it is in satisfactory condition

INSPECTIONS AND MAINTENANCE

Compare inspection results to the *RECORD*. Do not continue to use the product unless every component is in *SATISFACTORY CONDITION*. Cosmetic changes, like damaged paint/powder coat do not constitute changes from satisfactory condition. However, touchup paint should be applied to all affected areas as soon as damage occurs. Contact *TECHNICAL SERVICE* to order replacement parts. Contact information is provided on the cover page of this manual.

Inspect the following at least once per month:

1. Surfaces – Check all surfaces of the product for dirt or other matter, especially fluids. Clean the surfaces of the stand.
2. Hardware, fasteners – Examine hardware & fasteners (bolts, nuts, washers). Replace damaged/worn hardware.
3. Examine the frame for wear, breaks, corrosion/rust, metal fatigue, and other forms of damage (e.g. impact damage).
4. Labels– Replace labels that are damaged or not easily readable from a reasonable distance.
5. Overall structure – Examine the whole structure for rusting or metal erosion, rot, thinned regions. In particular, examine pivot points, and ground-contacting elements. If rusting is purely superficial, remove the rust/corrosion. Clean the affected area and apply touchup paint. If rusting, rot, or thinning has weakened the material, contact *TECHNICAL SERVICE* for advice.

LABELING DIAGRAM

Label content and locations are subject to change so your product might not be labeled exactly as shown. Compare this diagram to the *RECORD*. If differences exist between the diagram and the *RECORD*, contact *TECHNICAL SERVICE*. Replace all labels that are damaged, missing, or not easily readable (e.g. faded). To order replacement labels, contact the technical service and parts department online at http://www.vestilmfg.com/parts_info.htm. Alternatively, you may request replacement parts and/or service by calling (260) 665-7586 and asking the operator to connect you to the Parts Department.

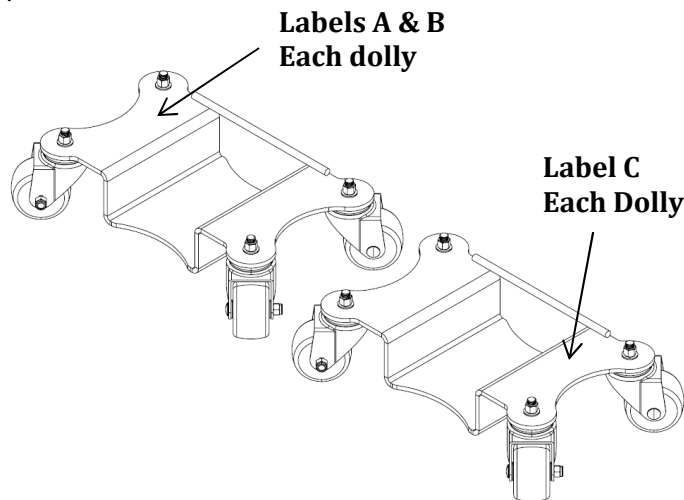

A: Label 220

⚠ WARNING	⚠ ADVERTENCIA	⚠ AVERTISSEMENT
KEEP CLEAR WHEN IN USE	MANTENGASE ALEJADO CUANDO SE ESTA OPERANDO	SE TENIR À DISTANCE LORS DU FONCTIONNEMENT

B: Label 658

⚠ WARNING	⚠ ADVERTENCIA	⚠ AVERTISSEMENT
Do not operate or move with unstable loads Do not load beyond rated capacity Distribute load evenly Do not sit or ride	No opere ni se mueva con cargas inestables No cargue más allá de la capacidad nominal Distribuya la carga de manera uniforme No se sienten ni conduzcas	No pas utiliser ou déplacer avec des charges instables No pas charger au-delà de la capacité nominale Répartir la charge uniformément Ne vous asseyez pas et ne montez pas

C: Label 1153 w/770 overlay

MODEL / MODÉLO / MODÈLE	_____
WEIGHT / PESO / MASS	_____
CAPACITY / CAPACIDAD / CAPACITÉ	_____
SERIAL / SERIE / SÉRIE	_____
UNITS: 2.2 lb. = 1kg	1" (or 1in.) = 2.54cm
1153	



LIMITED WARRANTY

Vestil Manufacturing Corporation (“Vestil”) warrants this product to be free of defects in material and workmanship during the warranty period. Our warranty obligation is to provide a replacement for a defective, original part covered by the warranty after we receive a proper request from the Warrantee (you) for warranty service.

Who may request service?

Only a warrantee may request service. You are a warrantee if you purchased the product from Vestil or from an authorized distributor AND Vestil has been fully paid.

Definition of “original part”?

An original part is a part used to make the product as shipped to the Warrantee.

What is a “proper request”?

A request for warranty service is proper if Vestil receives: 1) a photocopy of the Customer Invoice that displays the shipping date; AND 2) a written request for warranty service including your name and phone number. Send requests by one of the following methods:

<u>US Mail</u>	<u>Fax</u>	<u>Email</u>
Vestil Manufacturing Corporation 2999 North Wayne Street, PO Box 507 Angola, IN 46703	(260) 665-1339 <u>Phone</u> (260) 665-7586	info@vestil.com Enter “Warranty service request” in subject field.

In the written request, list the parts believed to be defective and include the address where replacements should be delivered. After Vestil receives your request for warranty service, an authorized representative will contact you to determine whether your claim is covered by the warranty. Before providing warranty service, Vestil will require you to send the entire product, or just the defective part (or parts), to its facility in Angola, IN.

What is covered under the warranty?

The warranty covers defects in the following original, dynamic parts: motors, hydraulic pumps, motor controllers, and cylinders. It also covers defects in original parts that wear under normal usage conditions (“wearing parts”), such as bearings, hoses, wheels, seals, brushes, and batteries.

How long is the warranty period?

The warranty period for original dynamic components is 90 days. For wearing parts, the warranty period is 90 days. Both warranty periods begin on the date Vestil ships the product to the Warrantee. If the product was purchased from an authorized distributor, the periods begin when the distributor ships the product. Vestil may, at its sole discretion, extend a warranty period for products shipped from authorized distributors by up to 30 days to account for shipping time.

If a defective part is covered by the warranty, what will Vestil do to correct the problem?

Vestil will provide an appropriate replacement for any *covered* part. An authorized representative of Vestil will contact you to discuss your claim.

What is not covered by the warranty?

The Warrantee (you) are responsible for paying labor costs and freight costs to return the product to Vestil for warranty service.

Events that automatically void this Limited Warranty.

- Misuse;
- Negligent assembly, installation, operation or repair;
- Installation/use in corrosive environments;
- Inadequate or improper maintenance;
- Damage sustained during shipping;
- Collisions or other accidents that damage the product;
- Unauthorized modifications: Do not modify the product IN ANY WAY without first receiving written authorization from Vestil.

Do any other warranties apply to the product?

Vestil Manufacturing Corp. makes no other express warranties. All implied warranties are disclaimed to the extent allowed by law. Any implied warranty not disclaimed is limited in scope to the terms of this Limited Warranty. Vestil makes no warranty or representation that this product complies with any state or local design, performance, or safety code or standard. Noncompliance with any such code or standard is not a defect in material or workmanship.