



Vestil Manufacturing Corp.

2999 North Wayne Street, P.O. Box 507, Angola, IN 46703

Telephone: (260) 665-7586 -or- Toll Free (800) 348-0868

Fax: (260) 665-1339

www.vestilmfg.com e-mail: info@vestil.com

RDC-100 & RDC-100-10 DRUM ROTATING CARTS ASSEMBLY INSTRUCTIONS

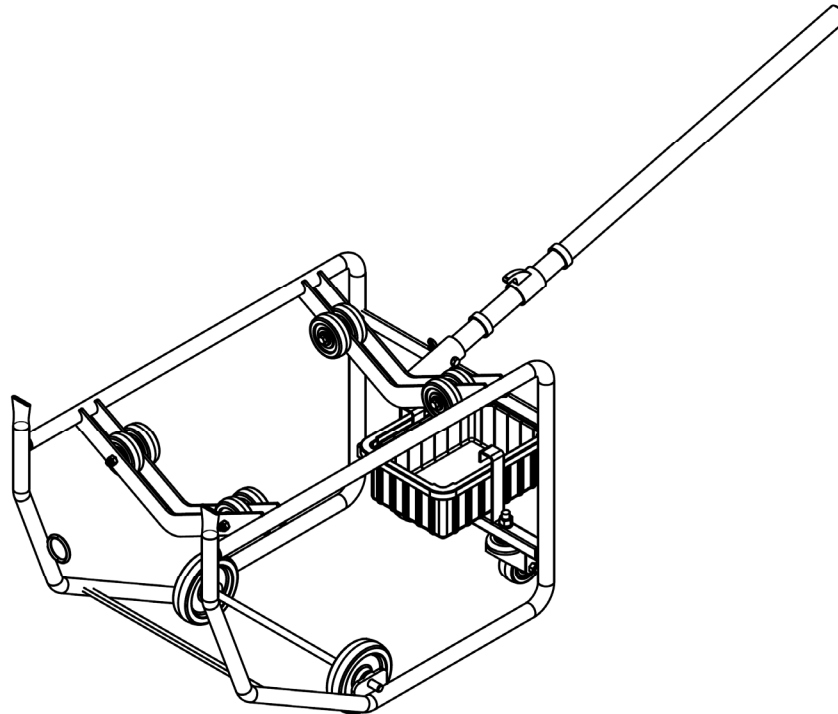

Receiving instructions:

After delivery, remove the packaging from the product. Inspect the product closely to determine whether it sustained damage during transport. If damage is discovered, record a complete description of it on the bill of lading. If the product is undamaged, discard the packaging.

NOTE:

The end-user is solely responsible for confirming that product design, installation, use, and maintenance comply with laws, regulations, codes, and mandatory standards applied where the product is used.

Table of Contents

Signal Words.....	2
Specifications.....	2
Hazards of Improper Use.....	2
DCR-100 exploded parts diagram and bill of materials.....	3
DCR-100-10 exploded parts diagram and bill of materials.....	4
Specifications.....	5
Assembly.....	5 - 6
Using the Cart.....	7
Inspections and Maintenance.....	8
Labeling Diagram.....	8
Limited Warranty.....	9

SIGNAL WORDS:

This manual uses SIGNAL WORDS to indicate the likelihood of personal injuries, as well as the probable seriousness of those injuries, if the product is misused in the ways described. Other signal words call attention to uses of the product likely to cause property damage.



Identifies a hazardous situation which, if not avoided, WILL result in DEATH or SERIOUS INJURY. Use of this signal word is limited to the most extreme situations.



Identifies a hazardous situation which, if not avoided, COULD result in DEATH or SERIOUS INJURY.



Indicates a hazardous situation which, if not avoided, COULD result in MINOR or MODERATE injury.



Identifies practices likely to result in product/property damage, such as operation that might damage the product.

Hazards of Improper Use:

Vestil strives to identify every foreseeable hazards associated with the use of its products. However, material handling is inherently dangerous and no manual can address every conceivable risk. Ultimately, the most effective means for preventing accidents is for the end-user to apply good judgment and foresight whenever using this product.



If this product is used improperly or carelessly, the user and/or bystanders might sustain serious personal injuries. To reduce the likelihood of injury:

- ***Read and understand the entire manual before assembling, using or maintaining the cart.***
- DO NOT modify this cart in any way UNLESS you first obtain written approval from Vestil. Unapproved modifications **automatically void the Limited Warranty (p. 9) and might make the cart unsafe to use.**
- DO NOT attempt to carry or transport loads that exceed the capacity of the cart. Capacity information appears in the “Specifications” table on p. # as well as on label 287 (see “Labeling Diagram” on p. 8.)
- ALWAYS secure drums to the cart with the (yellow) drum lock.
- DO NOT stand, sit, or ride on the cart. Only use this cart to move drums.
- Always watch the drum carefully while the cart is moving. If necessary, secure the drum to the cart, e.g. with ratchet straps.
- Do not attempt to go up or down sloped terrain with a loaded cart. Only use the cart on even, level ground when it is loaded. When unloaded, always control the cart from the uphill side while moving up or down slopes.
- Carefully rotate the cart to set the drum on the ground. If you cannot comfortably lift the drum and control the cart as it rotates, ask someone to assist you.
- Routinely inspect the cart according to the instructions in “Inspections and Maintenance” (p. 8).



Proper use, maintenance, and storage are essential to keep this cart in normal condition for as long as possible. Apply the inspection and maintenance procedures provided on p. 8.

- Regularly check all fasteners. Tighten loose nuts. Lubricate rollers, wheels, and casters whenever necessary.
- Inspect the handle, handle receiver, and retaining hardware for cracks, bends, etc.
- Examine the frame. Check all welds and frame members for cracks and severe corrosion/rusting.
- Clean the cart periodically.
- Remove rust with a steel bristle brush, clean the affected area, and cover it with touchup paint.
- Store the cart in a dry location.

RDC-100 exploded parts diagram and bill of materials

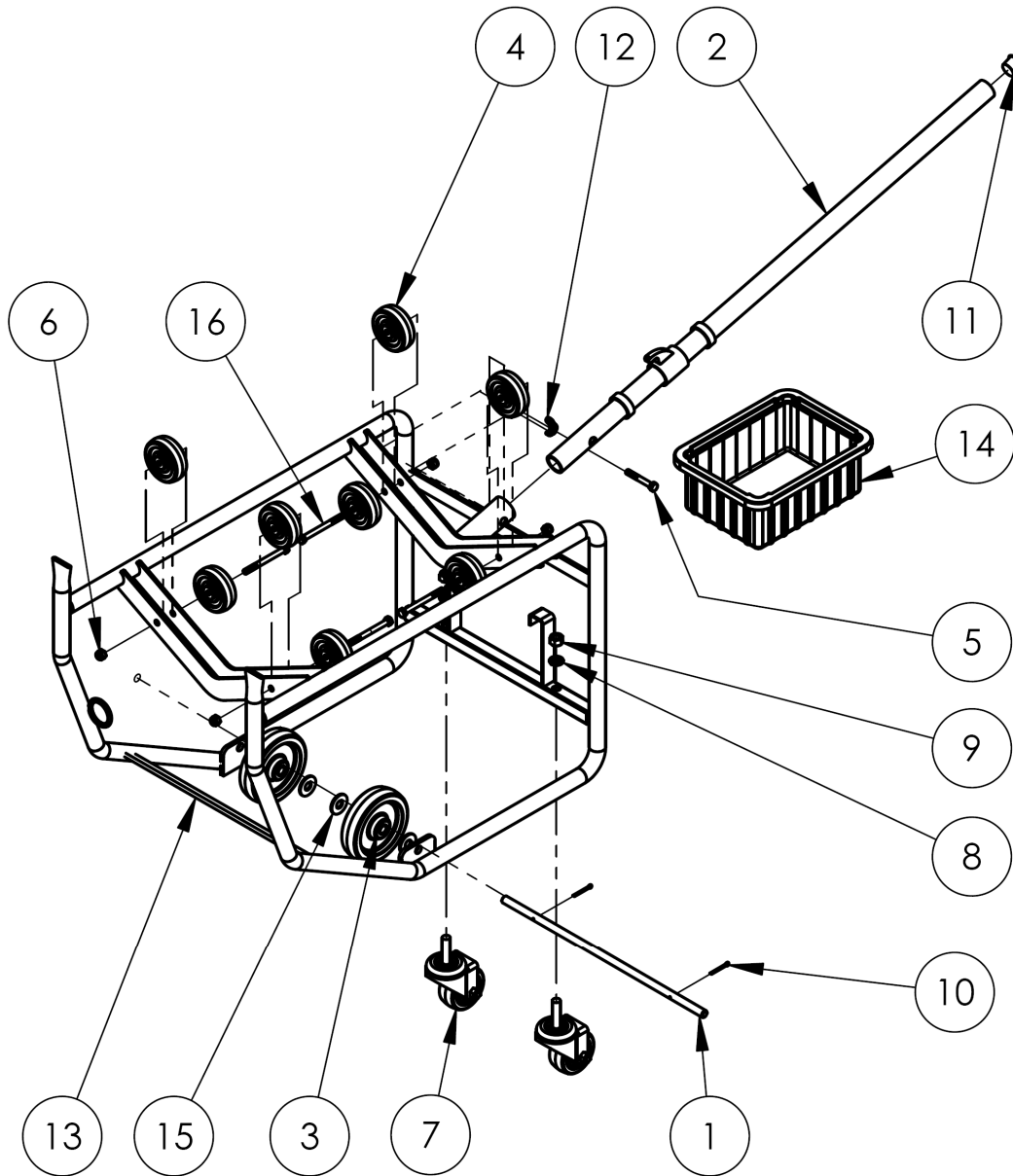

Item	Part no.	Description	Qty.	Item	Part no.	Description	Qty.
1	09-112-001	Axle, RDC	1	9	36109	Hex nut, gr. A, plain, 1/2"-13	2
2	09-525-001	Weldment, handle, RDC	1	10	65078	Extended prong cotter pin, zinc finish, 1/8"-1 1/2"	2
3	16-132-066	Wheel, PO-5/1.375-SLB	2	11	09-024-011	Blue cap, plug, general	1
4	16-132-061-001	Wheel, roller, HR-3/1-W	8	12	37748	Wing nut, 5/16"-18	1
5	11062	Bolt, HHCS, #2, zinc plated, 5/16"-18 x 2.25"	1	13	09-514-012	Weldment, frame, RDC-100	1
6	37021	Nylon insert lock nut, gr. 2, zinc finish, 5/16"-18	4	14	09-048-001	Tote, plastic drip pan	1
7	16-132-220	Caster, swivel with stem, HR-3/1.25-STM-2	2	15	33012	Flat washer, low carbon, zinc finish, 1/2"	4
8	33625	Lock washer, medium split, plain finish, 1/2"	2	16	11067	Bolt, HHCS, #2, zinc plated, 5/16"-18x3.5"	4

RDC-100-10 exploded parts diagram and bill of materials

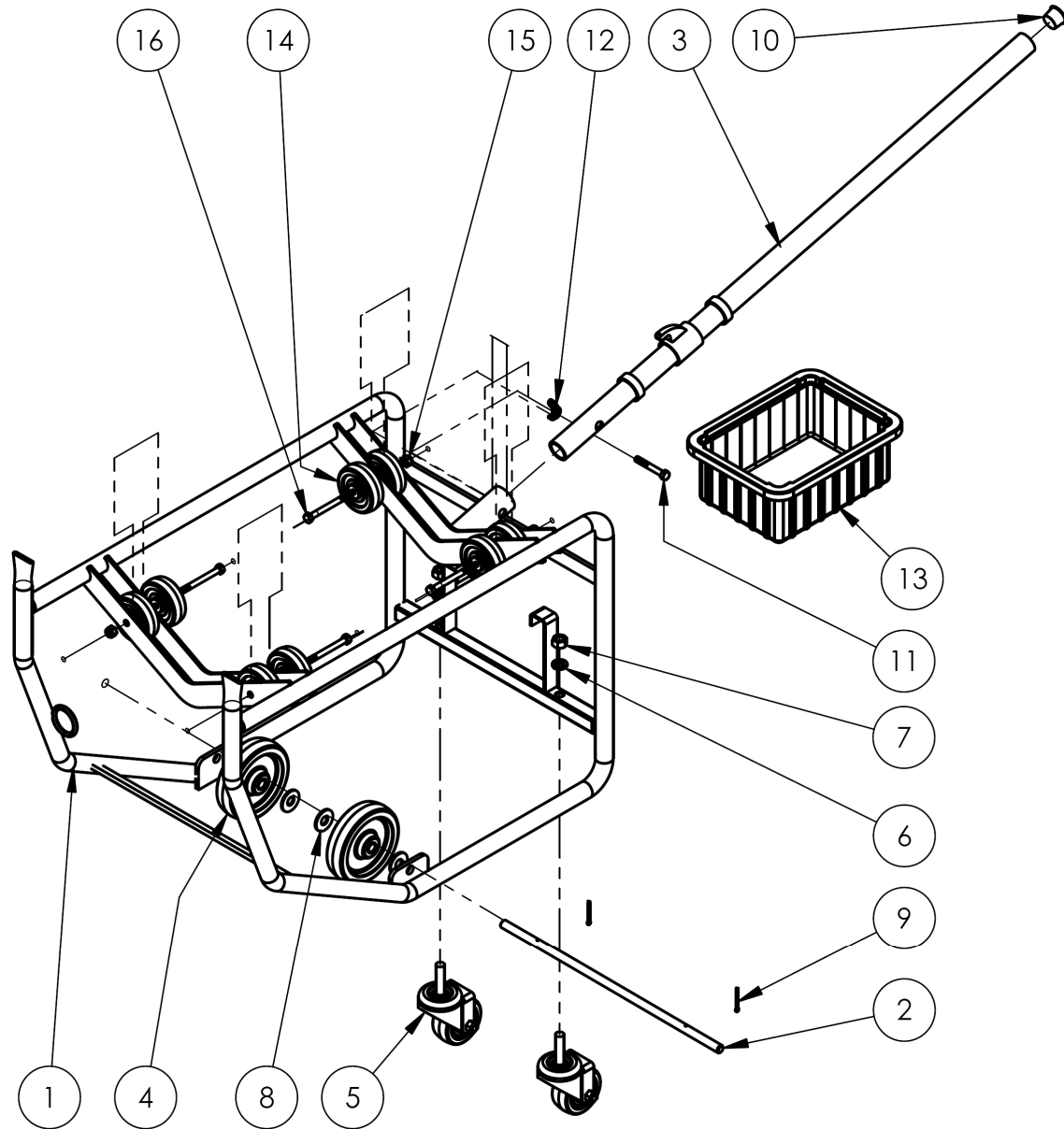

Item	Part no.	Description	Qty.	Item	Part no.	Description	Qty.
1	09-514-012	Weldment, frame, RDC-100	1	9	65078	Extended prong cotter pin	2
2	09-112-001	Axle, RDC	1	10	09-024-011	Blue cap, plug, general	1
3	09-525-001	Weldment, handle, RDC	1	11	11062	Bolt, HHCS, #2, zinc plated, 5/16"-18 x 2.25"	1
4	16-132-066	Wheel, PO-5/1.375-SLB	2	12	37748	Wing nut, 5/16"-18	1
5	16-132-220	Caster, swivel with stem, HR-3/1.25-STM-2	2	13	09-048-001	Tote, plastic drip pan	1
6	33625	Lock washer, medium split, plain finish, 1/2"	2	14	16-132-061-001	Wheel, roller, HR-3/1-W	8
7	36109	Hex nut, grade A, plain finish, 1/2"-13	2	15	37021	Nylon insert lock nut, gr. 2, zinc finish, 5/16"-18	4
8	33012	Flat washer, low carbon, zinc finish, 1/2"	4	16	11067	Bolt, HHCS, #2, zinc plated, 5/16"-18x3.5"	4

Specifications:

Dimensions and capacity information appears in the table and diagrams.

Model	Capacity	Net weight
RDC-100	600 lb.	178.5 lb. (81.1kg)
RDC-100-10	1,000 lb.	178.5 lb. (81.1kg)

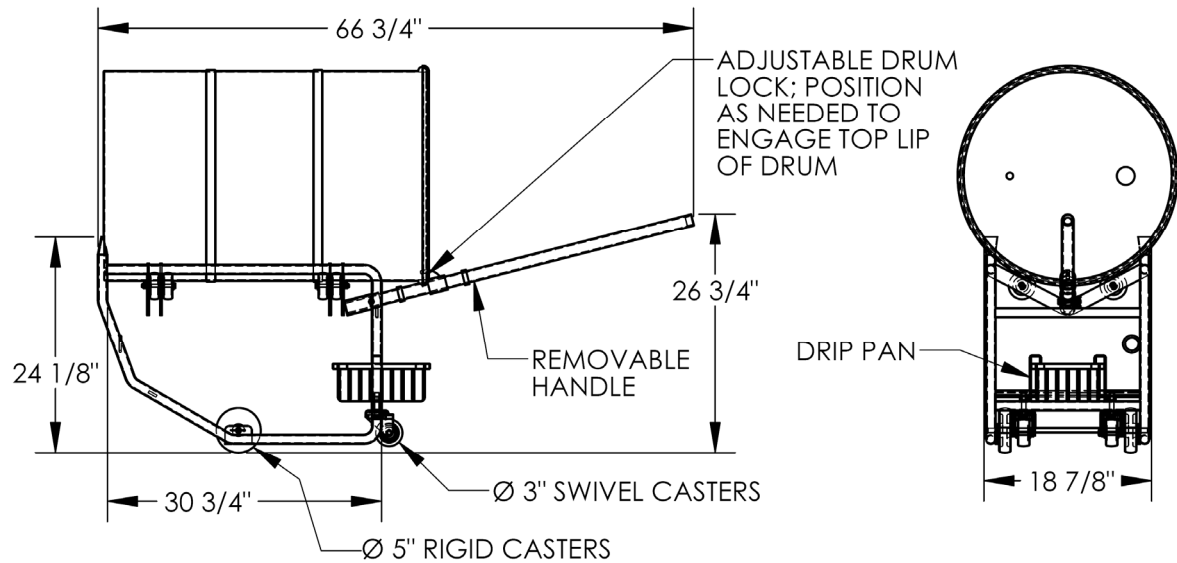

Assembly:

RDC-100 series drum carts require assembly before ready to use. Numbers in parentheses correspond to part numbers in the exploded parts diagrams on pages 3 & 4.

1. Insert the axle through one bracket. Before inserting it through the other bracket, slide the following items onto the axle:

- a. 1 flat washer (33012);
- b. A wheel (16-132-066);
- c. 2 more flat washers (33012);
- d. Another wheel (16-132-066); and
- e. 1 more flat washer.

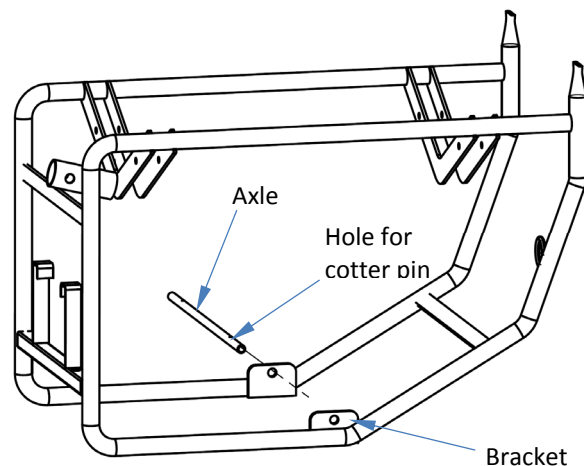

2. Insert the axle through the second bracket. Slide the wheels to opposite sides of the axle. There are 2 washers between the wheels. Push 1 of the washers against each wheel. Insert cotter pins (65078) through the pin holes in the axle. Bend the ends of the cotter pins around the axle.

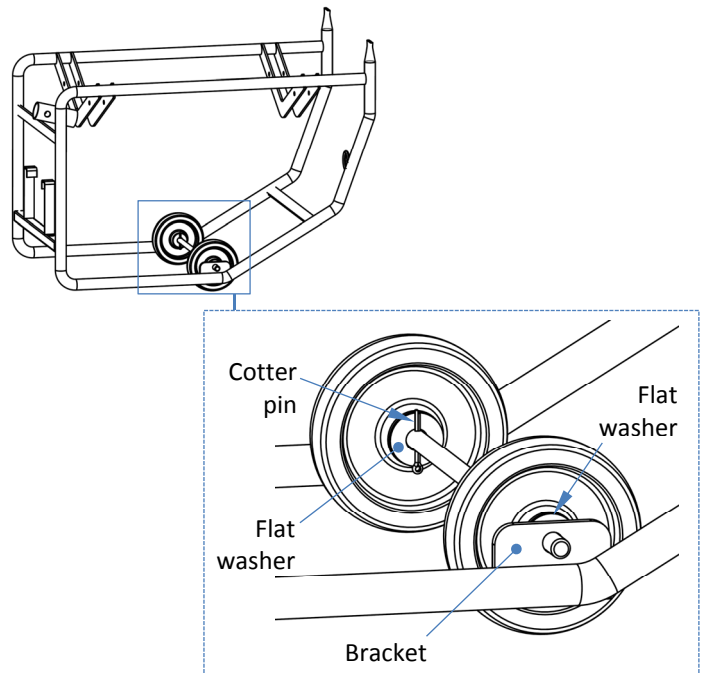

3. Attach the casters (16-132-220) to the frame with lock washers (33625) and hex nuts (36109) as shown in the diagram.

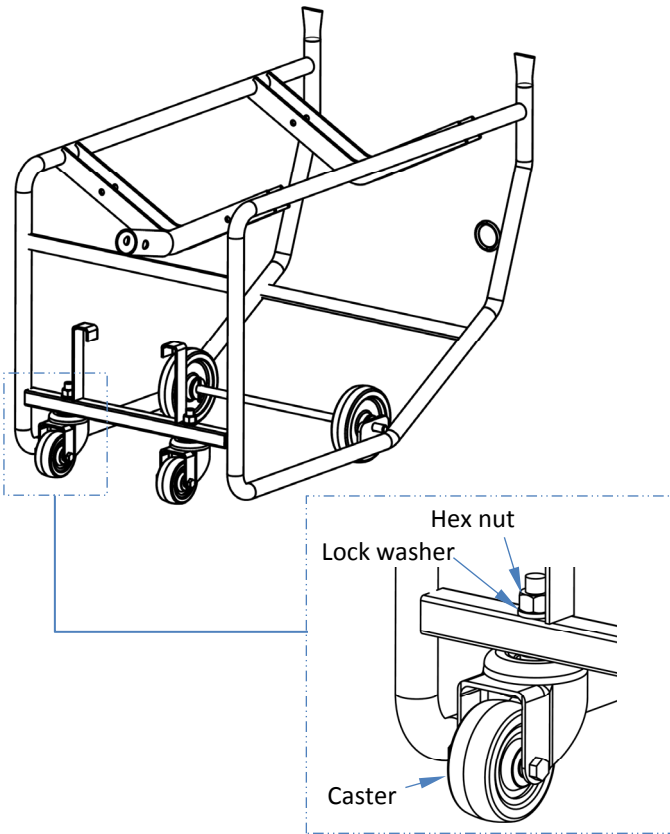

4. Install the drum rollers (16-132-061-001) in the drum cradle with hex bolts (11067) and lock nuts (37021).

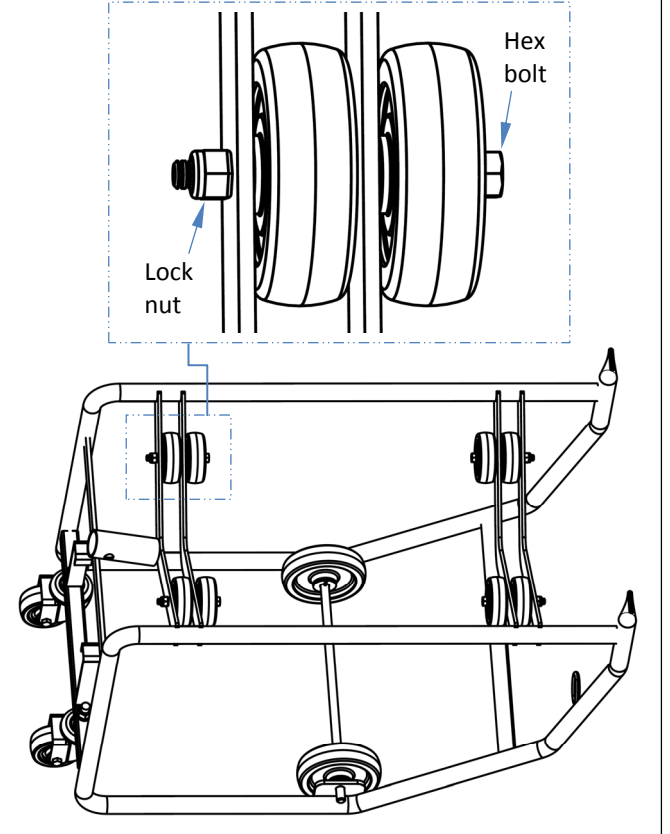

5. Install the drip pan (09-048-001). Tilt the pan and slide it under the retaining brackets.

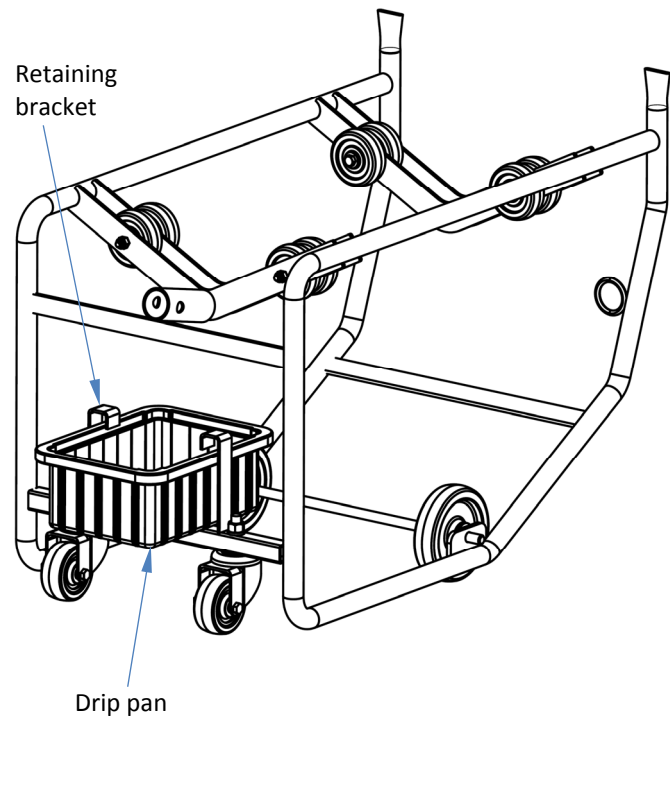

6. Insert the handle (09-525-001) into the handle receiver. Fasten the handle to the receiver with a hex bolt (11062) and wing nut (37748).

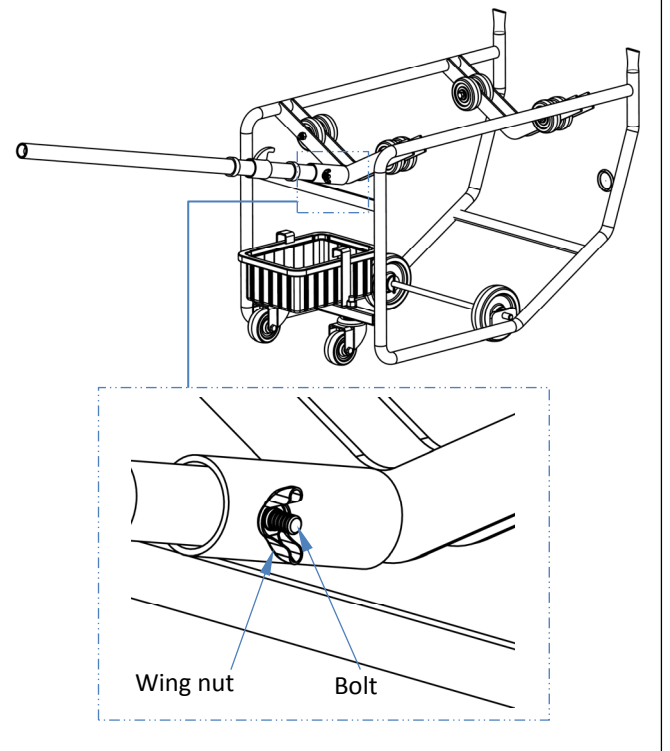

Using the cart:

To engage a drum with the cart:

1. Move the cart alongside the drum and rotate the cart to the upright position.
2. Slide the cart towards the drum. The drum retainers will contact the side of the drum.
3. Push the top of the cart forward (towards the drum). The rim hook should slide over the top of the rim and seat behind it.
4. Push the drum forward slightly until the bottom of the drum (by the drum retainers) lifts off of the ground.
5. Slide the drum retainers under the bottom of the drum.
6. Carefully rotate the cart back onto its wheels. When the cart and drum are horizontal, the drum is supported by the drum rollers. The drum can be rolled to orient it as needed.
7. Unload the cart by reversing steps 1-6. NOTE: When the cart is not in use, the handle can be removed and stored by inserting the end of the handle into the storage ring from the front of the cart.

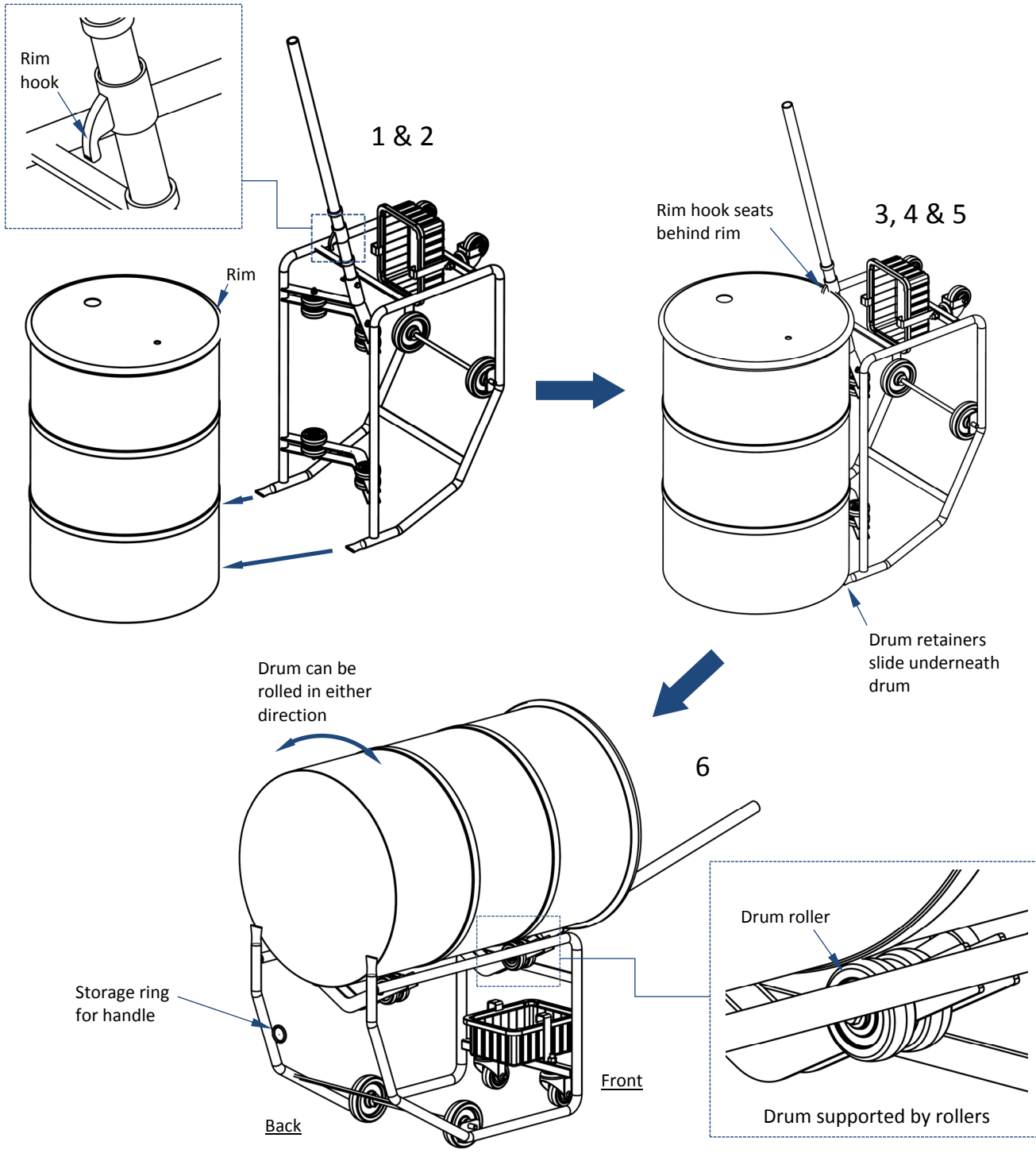

Inspections and Maintenance:

Before using the cart for the first time, create a written record of its appearance and functions. Include detailed descriptions about the frame, casters, wheels, rollers, and handle. Lift a drum with the cart by following the instructions in “Using the cart” on p. 7. Record observations about how the cart responds when weight is applied to it. Thoroughly photograph the unit including all labels applied to it. Add the photographs to your record. This written record establishes “normal condition”. When conducting future inspections, compare your observations with the record to determine if a component is in normal condition or requires repair or replacement.

Regular inspections and maintenance are necessary to keep the cart in normal condition for as long as possible. Do not use the cart unless it is in normal condition. Complete all necessary replacements and repairs before returning the cart to service.

Step 1: Tag the cart “Out of Service.”

Step 2: At least once per month, inspect the elements listed below. [Refer to “Parts Diagrams” on p. 3, 4.]

- a) **Frame:** Inspect all welds for cracks. Inspect the metal tubing for damage, warps, and cracks. Pay particular attention to areas where the wheels, rollers, and casters fasten to the frame. Make sure that all hardware is securely fastened together and that the bolt holes in the frame are not elongated, warped, or cracked.
- b) **Casters, wheels, and rollers:** Check each of the items for excessive wear, cracks, etc. Both casters and both wheels should solidly contact the ground and should roll smoothly without wobbling. Examine the center hub of each caster for cracks. Examine all (8) of the drum rollers.
- c) **Handle and handle receiver:** Confirm that the handle is securely fastened to the receiver (bolt and wing nut). Check the welds that fuse the receiver to the frame. Make sure that the receiver opening is not elongated, cracked, etc. Examine the handle for cracks, flattened regions, and other damage.

Step 3: Complete all necessary repairs/replacements. Deformities, severe corrosion or rusting, or excessive wear of any part warrants immediate replacement of that part. DO NOT return the table to service until adjustments and repairs are complete! NOTE: Adjustments and repairs differ significantly from modifications:

- a) **Adjustments & repairs** are simple correction that restores the cart to normal operating condition. Examples include tightening loose fasteners and lubricating moving parts.
- b) **Modifications** are changes that alter the cart from original condition, like bending the frame. NEVER modify the cart without express, written approval from Vestil. Modifications automatically void the limited warranty and might make the device unsafe to use.

Step 4: Make a dated record of all repairs, adjustments and replacements.

Step 5: Store the cart indoors in a dry location.

Labeling Diagram:

The table should always be labeled as shown in this diagram. However, label content and location are subject to change so your product might not be labeled exactly as shown. Thoroughly photograph the unit when you first receive it as discussed in the “Written Record” portion of the Inspections and Maintenance section (above). Make sure that your record includes a photograph of each label. Replace all labels that are, or later become, damaged, missing, or not easily readable (e.g. faded). Order replacement labels by contacting the Technical Service & Parts department online at http://www.vestilmfg.com/parts_info.htm or by calling (260) 665-7586 and asking the operator to connect you to the Parts Department.

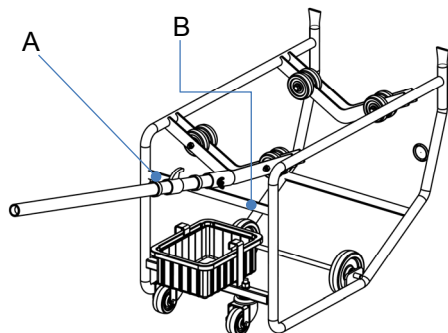

A: Label 287

MODEL/MODELO/MODELE	_____
STATIC CAPACITY (evenly distributed)	_____ lbs.
LA CAPACIDAD CONSTANTE (distribuida uniformemente)	_____ kgs.
CAPACITÉ STATIQUE (distribuée régulièrement)	_____ kgs.
SERIAL/SERIE/SÉRIE	_____
287 REV 0812	

B: Label 658

▲ WARNING	▲ ADVERTENCIA	▲ AVERTISSEMENT
Do not operate or move with unstable loads DO NOT LOAD beyond rated capacity DISTRIBUTE LOAD EVENLY DO NOT sit or ride	No use a mueva con cargas inestables No cargue mas de la capacidad tasada DISTRIBUYA LA CARGA A NIVEL NO SE SIENTE o vaya en el carro	Ne pas utiliser avec une charge instable NE PAS CHARGER au-delà du débit nominale DISTRIBUER la charge régulièrement NE PAS VOUS ASSEoir OU VOUS PROMENER sur le chariot

LIMITED WARRANTY

Vestil Manufacturing Corporation (“Vestil”) warrants this product to be free of defects in material and workmanship during the warranty period. Our warranty obligation is to provide a replacement for a defective, original part covered by the warranty after we receive a proper request from the Warrantee (you) for warranty service.

Who may request service?

Only a warrantee may request service. You are a warrantee if you purchased the product from Vestil or from an authorized distributor AND Vestil has been fully paid.

Definition of “original part”?

An original part is a part used to make the product as shipped to the Warrantee.

What is a “proper request”?

A request for warranty service is proper if Vestil receives: 1) a photocopy of the Customer Invoice that displays the shipping date; AND 2) a written request for warranty service including your name and phone number. Send requests by one of the following methods:

<u>US Mail</u>	<u>Fax</u>	<u>Email</u>
Vestil Manufacturing Corporation 2999 North Wayne Street, PO Box 507 Angola, IN 46703	(260) 665-1339 (260) 665-7586	info@vestil.com Enter “Warranty service request” in subject field.

In the written request, list the parts believed to be defective and include the address where replacements should be delivered. After Vestil receives your request for warranty service, an authorized representative will contact you to determine whether your claim is covered by the warranty. Before providing warranty service, Vestil will require you to send the entire product, or just the defective part (or parts), to its facility in Angola, IN.

What is covered under the warranty?

The warranty covers defects in the following original, dynamic parts: motors, hydraulic pumps, motor controllers, and cylinders. It also covers defects in original parts that wear under normal usage conditions (“wearing parts”), such as bearings, hoses, wheels, seals, brushes, and batteries.

How long is the warranty period?

The warranty period for original dynamic components is 90 days. For wearing parts, the warranty period is 90 days. Both warranty periods begin on the date Vestil ships the product to the Warrantee. If the product was purchased from an authorized distributor, the periods begin when the distributor ships the product. Vestil may, at its sole discretion, extend a warranty period for products shipped from authorized distributors by up to 30 days to account for shipping time.

If a defective part is covered by the warranty, what will Vestil do to correct the problem?

Vestil will provide an appropriate replacement for any *covered* part. An authorized representative of Vestil will contact you to discuss your claim.

What is not covered by the warranty?

The Warrantee (you) are responsible for paying labor costs and freight costs to return the product to Vestil for warranty service.

Events that automatically void this Limited Warranty.

- Misuse;
- Negligent assembly, installation, operation or repair;
- Installation/use in corrosive environments;
- Inadequate or improper maintenance;
- Damage sustained during shipping;
- Collisions or other accidents that damage the product;
- Unauthorized modifications: Do not modify the product IN ANY WAY without first receiving written authorization from Vestil.

Do any other warranties apply to the product?

Vestil Manufacturing Corp. makes no other express warranties. All implied warranties are disclaimed to the extent allowed by law. Any implied warranty not disclaimed is limited in scope to the terms of this Limited Warranty. Vestil makes no warranty or representation that this product complies with any state or local design, performance, or safety code or standard. Noncompliance with any such code or standard is not a defect in material or workmanship.

