



**STEP UP
SCAFFOLD**

SAFETY RULES AND INSTRUCTIONS

MULTIFUNCTION SCAFFOLD

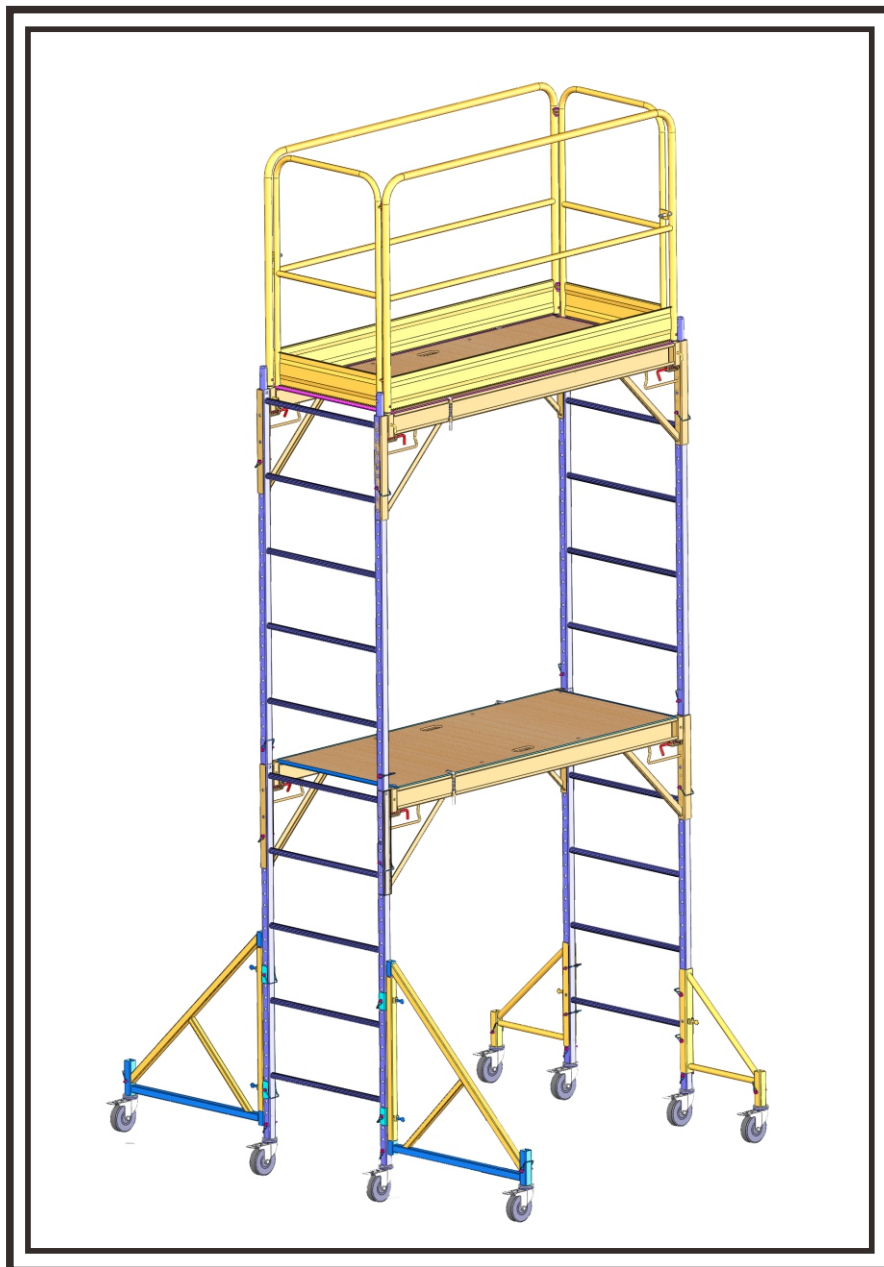

TABLE OF CONTENTS

| | |
|---|-------|
| Load Capacities & Stacking Information..... | 3 |
| Assembly Instructions: | |
| Building a One Frame High Scaffold | 4-5 |
| Building a Two Frame High Scaffold..... | 6 |
| Building a Three Frame High Scaffold | 7 |
| Dismantling Notes | 8 |
| Maintenance Procedures | 9-10 |
| Scaffolding Safety Rules | 11-12 |

WARNING

Improper erection, dismantling or use of Multifunction scaffold may result in serious injury or death!! Erectors, dismantlers and users of Multifunction scaffold must read and fully understand these Safety Rules and Instructions as well as all federal OSHA, state, and local regulations pertaining to this equipment prior to its use. For any questions concerning the proper erection, dismantling, or use of Multifunction scaffold, please call 1-888-STEPUP-1



2005 Fletcher Creek Dr.
Memphis, TN 38133-7509
Toll Free: 1-888-STEPUP-1

LOAD CAPACITIES

| |
|---|
| 6' Length Unit - 1000 lbs. (distributed load) |
| 8' Length Unit - 500 lbs. (distributed load) |
| 10' Length Unit - 500 lbs. (distributed load) |

STACKING INFORMATION - QUICK REFERENCE TABLE

| | Number of Frames High | Maximum Platform Height | Maximum Work Height | Guard Rail Required | Outriggers Required | Meets 3:1 Height to Base Req. | Meets 4:1 Height to Base Req. |
|--|-----------------------|-------------------------|---------------------|---------------------|---------------------|-------------------------------|-------------------------------|
| 6' Long Multifunction Scaffold | 1 | 6' | 12' 6" | * | No | Yes | Yes |
| | 2 | 11' 6" | 18' | Yes | Yes-Narrow | Yes | Yes |
| | 3 | 17' | 23' 6" | Yes | Yes - Wide | Yes | Yes |
| 8' Long Multifunction Scaffold | 1 | 6' | 12' 6" | * | No | Yes | Yes |
| | 2 | 11' 6" | 18' | Yes | Yes-Narrow | Yes | Yes |
| | 3 | 17' | 23' 6" | Yes | Yes - Wide | Yes | Yes |
| 10' Long Multifunction Scaffold | 1 | 6' | 12' 6" | * | No | Yes | Yes |
| | 2 | 11' 6" | 18' | Yes | Yes-Narrow | Yes | Yes |
| | 3 | 17' | 23' 6" | Yes | Yes - Wide | Yes | Yes |

* When platform height exceeds 4 ft., guard railing is recommended, but is not required. However, OSHA requires guard rails for all platforms 10 ft. or higher.

Pre-planning and study are essential for the proper and safe use of any scaffold equipment. You must first determine whether or not Multifunction scaffold is the best equipment for your particular job. You should discuss the following questions as well as any other questions you may have with your scaffold dealer or other qualified person:

- What job am I trying to complete?
- How high will I need to go?
- How large of a work platform will I need?
- Is the surface I am working on level?
- Are there any obstructions I will need to work around?
- Will the surface I am working on support the scaffold and its load?
- Will I need to move the scaffold from place to place on the jobsite?
- Are there power lines nearby?
- Are there any unique or special requirements for this job?
- Am I going high enough that I will need outriggers?

ASSEMBLY INSTRUCTIONS

BUILDING A ONE FRAME HIGH SCAFFOLD

For proper assembly, your Multifunction Scaffold must be comprised of 13 individual parts (plus guard rail panels when required).

| Letter | Part | Qty. |
|--------|--------------|------|
| A | Ladder Frame | 2 |
| B | Side Truss | 2 |
| C | Platform | 1 |
| D | 5" Caster | 4 |
| E | 2" Spin Pin | 4 |

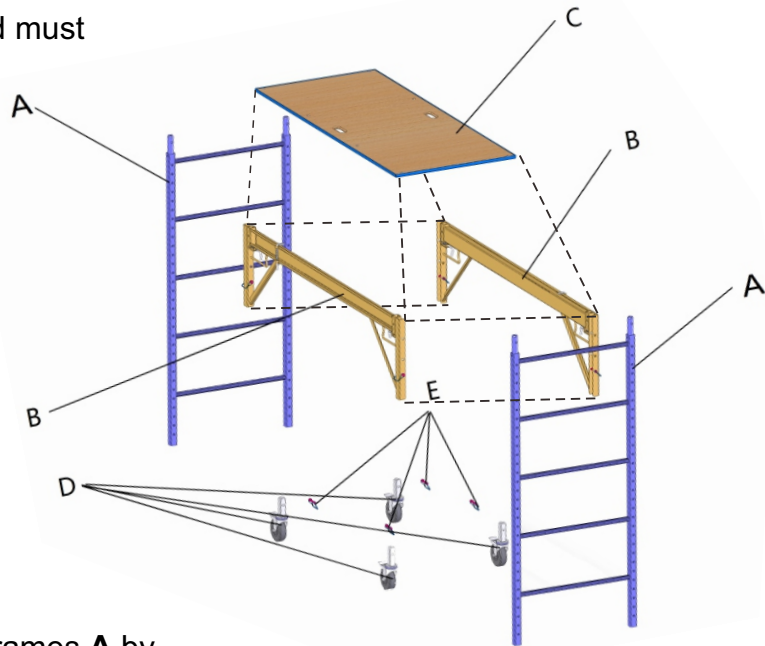

STEP ONE — Attach side brace **B** to two end frames **A** by following this sequence:

- Pull L-Shaped Lock pin at each end of side truss to the disengaged position. (see decal)
- While holding lock pin in disengaged position, place U-Channel on each end of side truss **B** around leg of ladder frame **A** at desired platform height.
- Release L-shaped lock pin and be sure that pin fully engages into hole in ladder frame leg as shown (LOCKED).

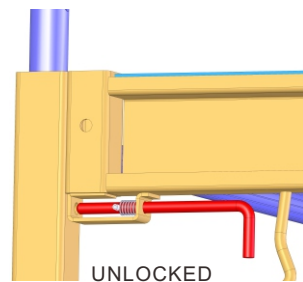
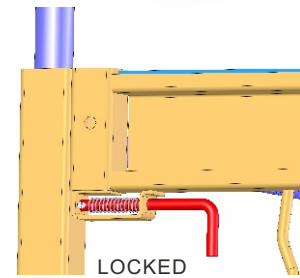

- To release, hold L-shaped Lock pin until U-shaped end unseats from around leg of ladder frame A
- as shown (UNLOCKED).

STEP TWO — Attach second side truss **B** to both end ladder frames **A** following the same Step One sequence

⚠ WARNING

- Both side truss must be positioned at the same height on the ladder frames so that platform is level.
- Be sure all 4 L-shaped lock pins are fully engaged in holes of end ladder frames.
- Be sure all 4 L-Shaped lock pin are in the locked position.

STEP THREE — Install platform **C** on side truss **B** so that platform is fully seated within inner channel on top of side truss

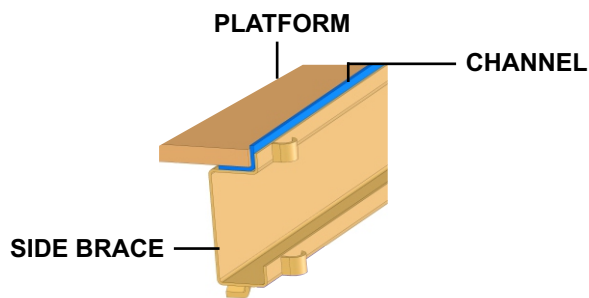

STEP FOUR — Rotate the platform clips into the engaged position.

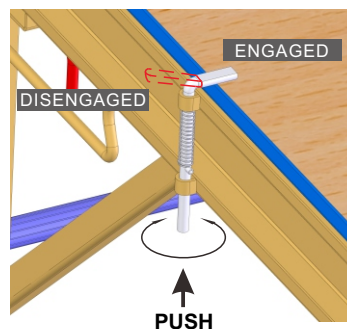

STEP FIVE — Install 4 casters **D** into legs of end ladder frames **A** and pin with snap pins **E**. Set on each caster.

STEP SIX — (When recommended or required) When platform height exceeds 4 ft., guard railing is recommended, but is not required. However, OSHA requires guard rails for all platforms 10 ft. or higher. Install each guard rail panel (2 required) into sockets in side truss **B** and secure with lock pin. Be sure that guard rail gate swings inward over the platform.

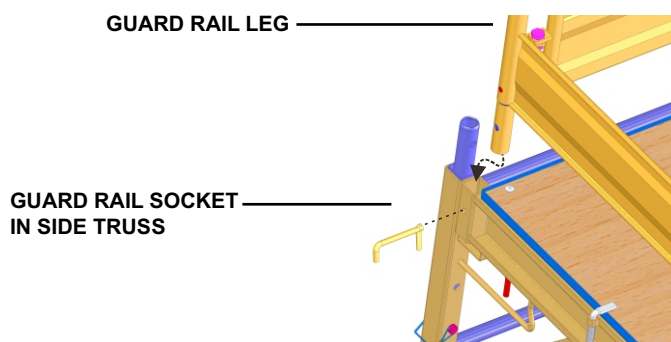

Unique design allows the guard railing to stay at the platform level at all times. Guard railing does not fit on the frame but in the sockets on the platform truss.

⚠ WARNING

Guard rail must be installed so that gate swings inward over platform. Failure to install guard rail properly may result in serious injury or death!

⚠ WARNING

Recheck all side truss lock pins for full engagement and that the L-shaped Lock pins in the locked position before accessing platform.

Recheck platform to be sure it is properly seated within side truss channel and the platform clips are fully engaged before accessing.

When accessing platform, climb over top of end frame ladder — do not swing around side of end ladder frame. Swinging around side of end ladder frame will cause scaffold to tip over resulting in serious injury or death.

STACKING MULTIFUNCTION SCAFFOLD UNITS FOR ADDITIONAL HEIGHT

According to OSHA, all scaffolds must be restrained from tipping. This can be accomplished in one of three ways:

1. For free standing scaffolds, the maximum platform height must not exceed 3 times* the narrowest base dimension.
2. Guying the scaffold.
3. Tying the scaffold to a wall or other solid structure.

*Federal OSHA allows a maximum platform height of 4 times the narrowest base dimension. However, **STEPUP SCAFFOLD** recommends that the maximum height be limited to 3 times the narrowest base dimension on all Multifunction scaffolds.

When additional platform height is required on a free standing scaffold, outriggers may be used to extend the base dimensions. **STEPUP SCAFFOLD** has different size outriggers available for use with Multifunction scaffold units. 18" wide outriggers are for use with two-frame high scaffolds and 24" wide outriggers are for use with three-frame high scaffolds.

WARNING

Whenever Multifunction scaffold units are stacked, outriggers are required! Do not use a Multifunction scaffold over 1 frame high without outriggers. Failure to use outriggers will make scaffold more likely to tip over causing serious injury or death!!

BUILDING A TWO FRAME HIGH SCAFFOLD

If the platform height needed is between 6' and 11' 6", it will be necessary to install 18" wide outriggers and a second scaffold level prior to use.

STEP ONE — Erect the base unit (one frame high scaffold) by following the previous instruction.

STEP TWO — Install casters into all four (4) outriggers and secure with snap pin provided with each caster. Set caster brake.

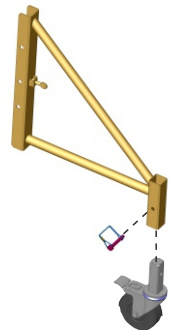

STEP THREE — Place U-Channel on each end of outriggers around leg of ladder frame **A**, make sure outrigger to end ladder frame at a 90° angle to the side truss and secure with snap pin and screwed gib-headed bolts by hand, casters must be in contact with the surface.

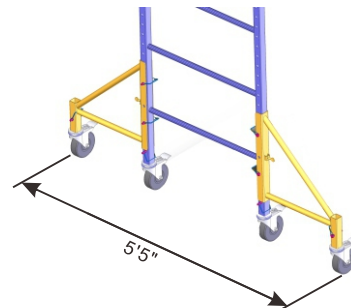

STEP FOUR — Add second scaffold level by stacking end ladder frame over insert pins in top of base unit end ladder frames. Secure in place with snap pins.



STEP FIVE — Install side truss (minimum two), platform, and guard railing at desired height per the previous instructions (Building a One Frame High Scaffold).

BUILDING A THREE FRAME HIGH SCAFFOLD

If the platform height needed is over 11' 6", it will be necessary to install 24" wide outriggers prior to stacking additional scaffold levels to the base unit.

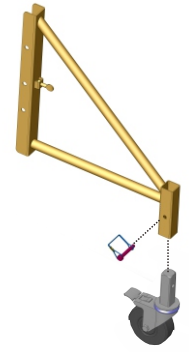

STEP ONE — Erect the base unit (one frame high scaffold) by following the previous instructions.

STEP TWO — Install casters into all four (4) wide outriggers and secure with snap pin provided with each caster. Set caster brake.

STEP THREE — Place U-Channel on each end of outriggers around leg of ladder frame **A**, make sure outrigger to end ladder frame at a 90° angle to the side truss. and secure with snap pin and screwed gib-headed bolts by hand, casters must be in contact with the surface.

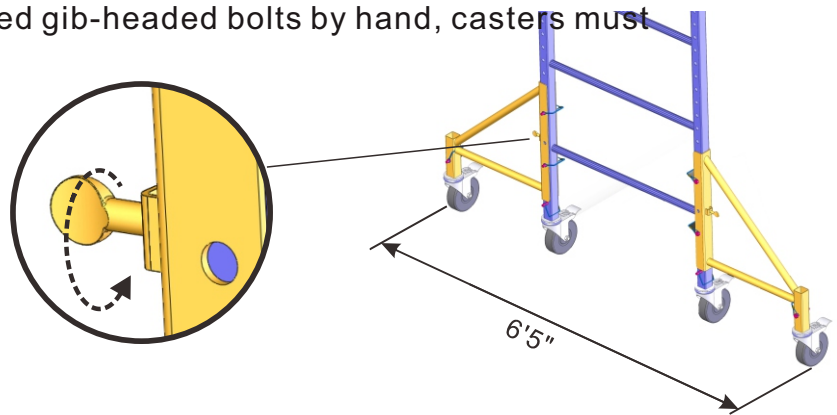

STEP FOUR — Add additional scaffold end ladder frames, side truss, platforms, and guard railing (at each work level) per the previous instructions (Building a One Frame High Scaffold and Building a Two Frame High Scaffold). Side braces should be evenly spaced in pairs throughout the scaffold tower.

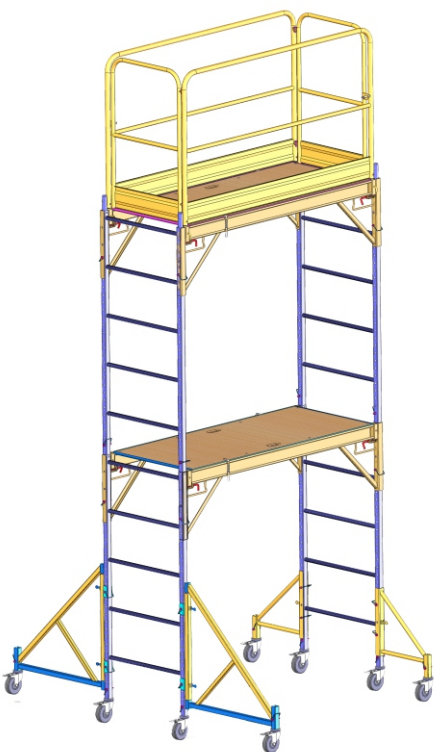

! WARNING

There must be a minimum of two side braces installed in each scaffold level and evenly spaced throughout the scaffold. Lack of adequate bracing could cause scaffold to collapse with serious injury or death to the user.

ADDITIONAL COMPONENT AVAILABLE

INSTALLATION OF WIDE BASE EXTENSION — Install by inserting base frame into vertical channels of wide base extension. Pin into place with snap pins.

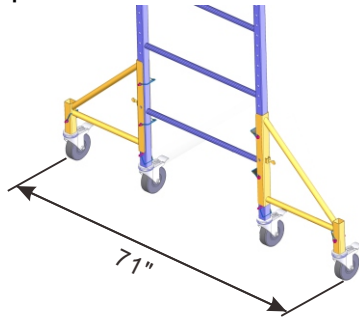

WIDE BASE EXTENSION

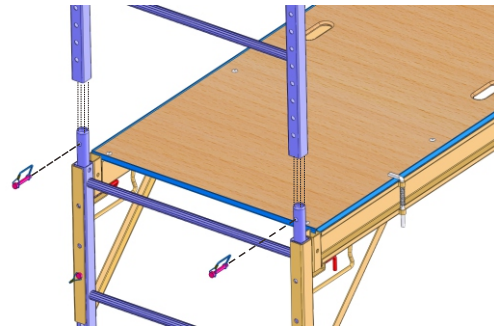

DISMANTLING NOTES

AS ADAPTED FROM THE SCAFFOLDING, SHORING & FORMING INSTITUTE (SSFI)

The work of dismantling scaffolding should be under the supervision of an individual with proper experience and aptitude (competent person). The following should be observed while dismantling.

1. It shall be the responsibility of employees to read and comply with the following common sense guidelines which are designed to promote safety in the dismantling of scaffolding. These guidelines do not purport to be all inclusive nor supplant or replace other additional safety and precautionary measures that may be necessary to cover usual or unusual conditions.
2. Check to see if scaffold has been structurally altered in any way which would make it unsafe; and, if so, reconstruct where necessary before commencing with the dismantling procedures.
3. Dismantle scaffold from the top down. Begin by removing all accessories from that section being dismantled at the time.
4. On stacked scaffolds do not remove ties and braces until dismantling has reached the section to which they are attached.
5. Always work within the inside of the scaffolding.
6. When moving up or down the scaffold do **not** climb on ties, braces or unbraced components. Climb over the top of the end frame. Do not swing around outside of the end frame.
7. Be sure that area below is clear of personnel not involved in the dismantling and is secured against unauthorized access.
8. Lower scaffold components in a safe manner as they are dismantled. Avoid dropping or throwing the components as this could result in injury to personnel below, or damage to the equipment.
9. Use energy absorbing lanyards and full body harness when feasible.

MAINTENANCE PROCEDURES

For Multifunction scaffold Components

The following recommendations for maintenance are generalized and not intended to cover every specific situation or component. Safe Practices and common sense should be followed at all times. In case of doubt as to the best maintenance procedures to follow, please contact your Multifunction scaffold supplier

IMPORTANT

1. SCAFFOLDING EQUIPMENT SHOULD NOT BE ALTERED OR MODIFIED FROM ITS ORIGINAL CONFIGURATION WITHOUT CONSULTATION WITH THE MANUFACTURER. EQUIPMENT WHICH IS DAMAGED OR BECOMES DAMAGED DURING USE, HANDLING, OR SHIPPING SHOULD BE SET ASIDE AND NOT USED.
2. PERTINENT OSHA REGULATION CFR 1926.451(a) (8) states: Any scaffold including accessories such as arm braces, screw legs, ladders, brackets, etc. damaged or weakened from any cause shall be immediately repaired or replaced.
3. ANY SCAFFOLDING WILL BE HANDLED BY NUMEROUS PARTIES after it leaves the manufacturer/supplier. The ultimate responsibility of avoiding the use of damaged equipment rests with the final user who has custody of it. A voidance of hardship or inconvenience never justifies the use of damaged scaffolding equipment, which may result in severe injuries to personnel using such scaffolds.
4. Always read and follow Scaffolding Safety Rules accompanying these instructions or separately available at your request.

VISUAL INSPECTION

EQUIPMENT WITH THE FOLLOWING OR OTHER TYPES OF DAMAGE, SHOULD NOT BE USED UNTIL PROPERLY REPAIRED, OR REPLACED. CHECK ALL COMPONENTS FOR:

- | | |
|---|--|
| A. Straightness of members. | |
| B. Welds that appear excessively rusty. | protection, support braces, or damaged plywood. |
| C. Broken welds or cracks at or adjacent to a weld - sometimes discernible as a thin rust line. | H. Casters with missing or damaged braking mechanism, damaged or loose wheels, axles, or stems. |
| D. Cracks around part or all the circumference of tube members, not necessarily at a weld site. Rust line may be a visual telltale. | I. EXCESSIVE RUST - (also see para. (B) under Other Considerations). The strength of excessively rusted components is not known. |
| E. Tubular members that are crushed, flattened or kinked. End frame, arm braces, and other members having this kind of damage may no longer be able to support their intended design loads. | J. End frames or other components with broken welds, missing parts, or which are bent, bowed, or out of alignment. Replace missing parts before use (see note (G) following). |
| F. Arm braces with broken or cracked welds, distorted shape or with broken or deformed U-channel. Arm braces with damaged or inoperable lock mechanisms including broken spring. Arm braces immediately support platforms and personnel and must always be checked very carefully. If in doubt, do not use. | K. Paint surfaces which are cracked and/or show areas where the paint has crazed; such signs may indicate prior damage and subsequent straightening. Such damage may also have overstressed the metal and weakened it. |
| G. Platforms with bent, missing or broken edge | |

(Continued on next page)

REMEDIES AND REPAIRS

- A. Bent or distorted members may be cold straightened only - **NEVER USE HEAT TO STRAIGHTEN SCAFFOLDING COMPONENTS**. After straightening, inspect the metal for developed cracks; if it still shows kinks or depressions, it has been weakened at that point and should not be used until repaired, if repairs are possible.
- B. Broken welds at tubular or other joints may be repaired. The entire weld around the joint must be repaired - not merely the broken portion.
- C. Splits along original seams of tubes may be rewelded if they do not extend more than 1-1/2 along their seams.
- D. Cracks around part or all the circumference of a tube may **never** be repaired by welding. Do not use components with this type of damage.
- E. After rewelding, smooth the weld, remove the scale, clean the surrounding heat-affected zone, and repaint the whole area. Rewelded areas will usually rust more quickly than the surrounding painted areas. Worn or old paint still provides some protection.
- F. When replacing broken weldments, lock pins, springs, and other missing parts, always use the proper parts obtained from the original manufacturer/supplier or authorized agent. Substitution of other parts or makeshift devices may impair the fit with other components and may create user-hazards.
- G. End ladder frames and other major components that are more than 2 out of line are generally beyond straightening. Components which are difficult or impossible to connect together may be slightly bent, bowed, or racked out of line, and should be straightened before reusing. **NEVER FORCE COMPONENTS TO MAKE THEM FIT!**

NOTE: ALL WELDING MUST BE DONE BY CERTIFIED WELDERS ONLY!

OTHER CONSIDERATIONS

- A. RUST. Some rusting of steel components is normal over a period of time, especially in areas where paint has been scraped off due to normal use and handling.
- B. EXCESSIVE RUST - evidenced by pitting, flaking or powdering to the touch indicated that some of the parent metal has been eaten away. Such components are of uncertain strength and should not be used.
- C. Certain types of atmospheric contamination, such as from salt water, power plants, paper pulp mills, petrochemical and copper or similar processing plants may severely corrode steel after relatively short exposures. Such corrosion may appear to be rust but is often of a brighter or different color than normal. Equipment of an unusual color, all over or in parts, must be checked for chemical corrosion or contamination. It is dangerous to continue to use such corroded components.
- D. Equipment exposed to fire or undue heat may exhibit a gray, or smoke-blackened appearance combined with possible blistering paint. Such heat generally affects the strength of the material and makes it dangerous to continue its use.
- E. Heat or corrosion-damaged equipment is of uncertain strength, which may only be determinable by destructive testing of all equipment suspected of being so damaged. **EQUIPMENT SUBJECT TO DESTRUCTIVE TESTS CANNOT BE RETURNED TO SERVICE.**
- F. The performance of all equipment is improved by regular maintenance, such as removal of plaster and other construction materials, lubrication as appropriate and painting periodically. If repainted, dipping or spraying by a method which assures that the paint gets to the inside of tubular members is recommended. Always thoroughly inspect for cracks and other damage before repainting.

SCAFFOLDING SAFETY RULES

SERIOUS INJURY OR DEATH MAY RESULT FROM IMPROPER ERECTION OR USE of scaffolding equipment. Erectors and users must be familiar with and follow safe practice and the Safety Rules contained herein. These Safety Rules cover generalized situations only and do not purport to be all-inclusive, nor to supplant or replace other additional safety and precautionary measures that may be necessary to cover the many usual or unusual specific conditions encountered during installation, use and removal. The Rules are not intended to conflict with, or supersede the requirements of OSHA or any other governmental regulations, codes and ordinances; the user must refer to and comply with all such specific provisions of law. **FOLLOW SAFE PRACTICE, THE SAFETY**

- A. RULES AND COMPLY WITH OSHA** and all other federal, state and local regulations, codes and ordinances pertaining to scaffolding during any use of the equipment.
- B. THE POTENTIALLY HAZARDOUS NATURE OF SCAFFOLDING ERECTION WORK** makes it important that all personnel assigned to this work be instructed in these Safety Rules, safe practices and procedures and be under the supervision of an experienced and knowledgeable person. Assure that these Safety Rules are posted conspicuously and that all persons erecting and using the scaffold are aware of and follow them.
- C. REPORT ANY UNSAFE CONDITIONS TO SUPERVISORS.** Do not work or allow persons to work on scaffolds when sick or suffering from dizziness, unsteadiness or other physical symptoms which could affect their ability to work safely.
- D. INSPECT ALL EQUIPMENT BEFORE USING.** Never use any equipment which is damaged, defective or deteriorated in any way.
- E. INSPECT ERECTED SCAFFOLD FREQUENTLY** and be sure that they are maintained in safe condition, that scaffold connections have not become loosened and that components have not been improperly released or removed.
- F. MAINTAIN ALL EQUIPMENT IN GOOD REPAIR.** Never use corroded or excessively rusted equipment; the strength of such equipment is not known.
- G. CONSULT YOUR SCAFFOLDING SUPPLIER WHEN IN DOUBT. NEVER TAKE CHANCES.**
- H. ALWAYS READ THESE SAFETY RULES** in conjunction with the safety packet accompanying them or separately available from STEPUP scaffold upon request.
- 1. ALWAYS SUPPORT SCAFFOLDS FROM A SOUND, STABLE SURFACE** and assure that it is adequate to support the intended scaffold loads. Never support scaffolds on unstable, loose objects which could tip, break or become dislodged.
 - 2. LIFT AND LOWER COMPONENTS CAREFULLY AND SAFELY;** use tag lines when appropriate to the handling method. Never allow excessive quantities of components to be stockpiled on partially complete scaffolds. Stock only sufficient components consistent with the progress of the work. Lower dismantled components as soon as possible. Never drop components deliberately.
 - 3. THE TYING OF THE SCAFFOLD TO THE STRUCTURE IS OF GREAT IMPORTANCE TO** the stability and safety of the scaffold. Assure that the structure to which the scaffold is tied or anchored is capable of safely supporting all loads imposed by the scaffold.
 - 4. FREE STANDING SCAFFOLDS** other than wall scaffolds must be restrained from tipping by guying or other means or otherwise stabilized as appropriate, recognizing that stability is essential to the safety of the scaffold.
 - 5. INSTALL GUARDRAILS, MID-RAILS, AND TOEBOARDS** at all openings, open sides and ends of every work platform when recommended or required.
 - 6. NEVER USE LADDERS OR MAKESHIFT DEVICES** on tops of scaffold to increase the height. Never place plank on or stand on guardrails and mid-rails.
 - 7. POWER LINES NEAR SCAFFOLDS ARE DANGEROUS.** Use extreme caution and consult the power service company to have the lines de-energized, insulated or otherwise rendered safe. Never allow any installation or use of scaffolds until this is done.

REFER TO AND COMPLY WITH ALLOWABLE LOAD DATA SHOWN ON PAGE 3.

8. **WHEN ANY CANTILEVERS ARE USED**, such as brackets, etc., proper care and precautions must be taken to prevent tipping of the scaffold.
9. **FOR ROLLING SCAFFOLDS FOLLOW THESE ADDITIONAL SAFETY RULES:**
 - a. Never ride rolling scaffolds.
 - b. Remove all materials and equipment from the scaffold before moving.
 - c. Lock caster brakes at all times the scaffold is not being moved.
 - d. Do not attempt to move rolling scaffolds without sufficient help and roll on level surfaces only. Watch out for holes or floor obstructions and for overhead obstructions, including power lines, energized craneways, and other hazards.
 - e. The maximum platform height of a rolling scaffold must not exceed four (4) times the narrowest dimension. Check local State/ OSHA Regulations for other height/base limitations such as 3:1 in CA, OH, OR, MT and ME. Comply with these regulations by appropriately widening and/or lengthening the scaffold at the lower levels so that the above proportions are not exceeded. If the base dimensions cannot be increased, extreme care must be taken to secure the scaffold from tipping; it must be guyed, or tied to a solid structure and maintained in a stabilized condition at all times so that it cannot tip over while supporting persons, while being moved or while being erected or dismantled.
 - f. Apply pulling or pushing forces at the bottom end ladder frames And as close to the scaffold base as possible. Never attempt to move scaffold from on top.
 - g. If rolling scaffolds are used outdoors, care must be taken to assure that they cannot become unstable due to wind or other conditions.
10. **DO NOT OVERLOAD SCAFFOLDS.** Refer to and do not exceed the scaffold load data shown on page 3. For further information relative to specific scaffold installations that do not fall within this data, consult your STEPUP scaffold supplier.
11. **BECAUSE OF DIFFERENCES IN DESIGN AND FIT**, do not intermingle scaffold components of different manufacture.

REFER TO AND COMPLY WITH ALLOWABLE LOAD DATA SHOWN ON PAGE 3.



**STEPUP
SCAFFOLD**