

OWNERS MANUAL

STOCKPICKER TRUCKS

Contents

Warnings and Safety Instructions	1	Warranty	1
Receiving Instructions	1	Parts Identification	2

WARNINGS & SAFETY INSTRUCTIONS

Read owner's manual completely before operating unit!

- Remove weight before working on unit.
- Use only maintenance parts supplied or approved by the manufacturer.
- Consult factory for uneven loading.
- Make sure all operator safety labels are in place.

RECEIVING INSTRUCTIONS

Every unit is thoroughly tested and inspected prior to shipment. However, it is possible that the unit may incur damage during transit. If you see damage when unloading make a note of it on the SHIPPER RECEIVER.

Remove all packing and strapping material and inspect unit for damage. **IF DAMAGE IS EVIDENT, FILE A CLAIM WITH THE CARRIER IMMEDIATELY!**

MODEL NUMBER AND CAPACITIES

The model number and capacity is located on the nameplate. Please remember to include these numbers in any correspondence with your dealer or the factory.

LIMITED WARRANTY

ONE YEAR LIMITED WARRANTY. The manufacturer warrants for the original purchaser against defects in materials and workmanship under normal use one year after date of purchase. (Not to exceed 15 months after date of manufacture.) Any part which is determined by the manufacturer to be defective in material or workmanship and returned to the factory, shipping costs prepaid, will be, as the exclusive remedy, repaired or replaced at our option. Labor costs for warranty repairs and/or modifications are not covered unless done at manufacturer's facilities. Any modifications performed without written approval of the manufacturer may void warranty. This limited warranty gives purchaser specific legal rights which vary from state to state.

LIMITATION OF LIABILITY. To the extent allowable under applicable law, the manufacturer's liability for consequential and incidental damages is expressly disclaimed.

The manufacturer's liability in any event is limited to, and shall not exceed, the purchase price paid. Misuse or modification may void warranty.

WARRANTY DISCLAIMER. Our company has made a diligent effort to illustrate and describe the products shown accurately; however, such illustrations and descriptions are for the sole purpose of identification, and do not express or imply a warranty that the products are merchantable, or fit for a particular purpose, or that the products will necessarily conform to the illustrations or descriptions.

The provisions of the warranty shall be construed and enforced in accordance with the **UNIFORM COMMERCIAL CODE** and laws as enacted in the State of Indiana.

DISPOSITION. Our company will make a good faith effort for prompt correction or other adjustment with respect to any product which proves to be defective within the Limited Warranty. Warranty claims must be made in writing within said year.

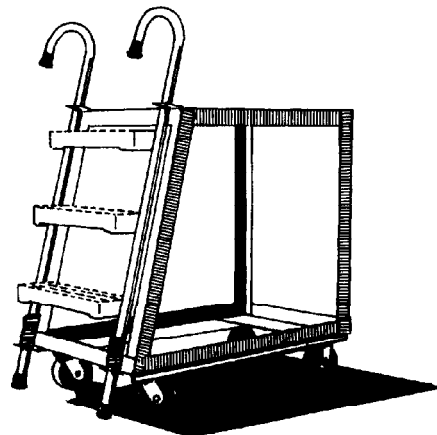

STOCKPICKER TRUCKS

PARTS IDENTIFICATION

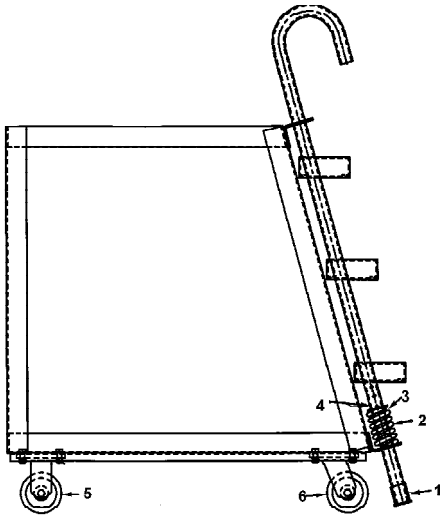

MODEL SPS2-2236

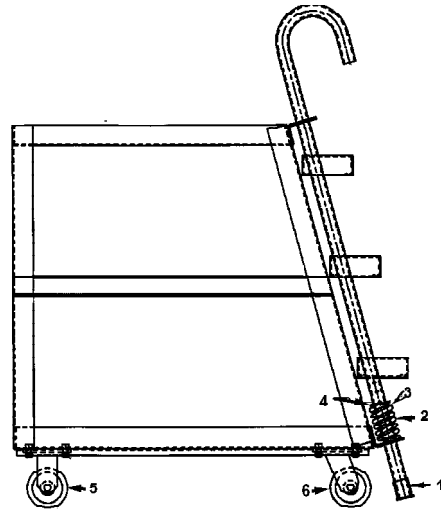

MODEL SPS3-2236

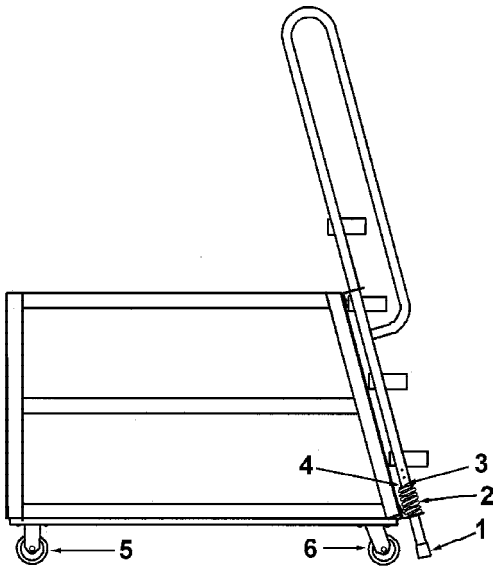

MODEL SPS-HD-2252

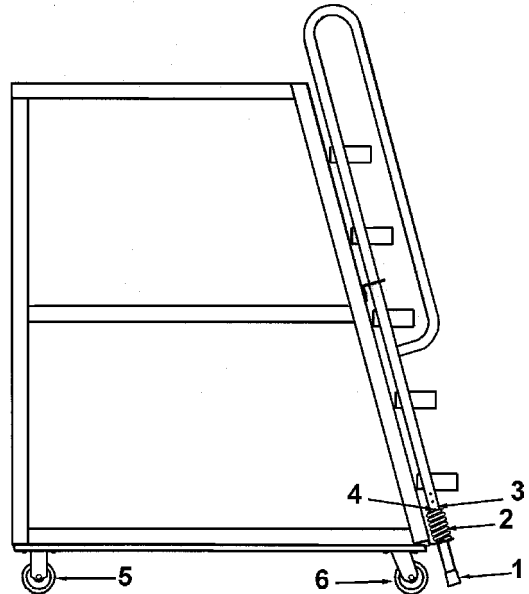

MODEL SPS-HF-2852

NO.	DESCRIPTION	ENGINEER NO.	PART NO.
1	Rubber Ladder Tip	SPS-LT	SPA2-2236
2	Spring	16-146-001	SPS-SPG
3	Spring Pin 1/4 x 3/4	64253	SPS-SPGPN
4	Machinery Bushing 18 Gauge x 1-3/8"	33471	SPS-MB
5	Rigid Caster 4 x 2	16-132-012	SPS-RC
6	Swivel Caster with Brake 4 x 2	16-132-054	SPS-SWC
Wheel Kit (2 rigid & 2 swivel casters)			SPA2-WH-KIT