

**Ergonomic Solutions**

# OWNER'S MANUAL

## TWO-TIER SERVICE CART MODEL STC-1835

### ASSEMBLY INSTRUCTIONS

1. Install the swivel casters (9) and rigid casters (13) onto the bottom deck (6). (Note: the rigid casters should be assembled on the "U" block with Right angle.) Then secure them with the M10x30 outer hexagonal bolts, flat washer (10) and M10 locknuts.
2. Insert the threaded ends of the upright posts (4) into the four square holes on the bottom deck. Put the 14 flat washers (7) on, and lock it with the M14 locknut (8), then install the top deck (5) on the four upright posts(4). (Note: the top deck should be assembled smooth surface up.) Secure the top deck (5) and the upright posts (4) with the M12x45 hexagon socket button head screws (2).
3. Assemble the handle on both sides of the top deck, align the holes, and secure it with the M8x25 outer hexagonal bolts (3).
4. Check all the hardware to make sure that everything is tightened securely.

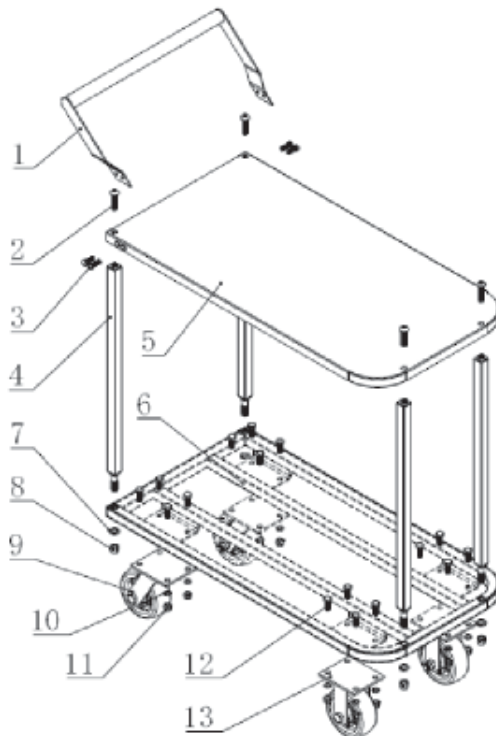

ITEM NO.	DESCRIPTION	QTY.
1	Handle	1
2	M12 x 45 Hexagon socket button head screws	4
3	M8 x 25 Outer hexagonal bolts	4
4	Upright bar	4
5	Upright panel	1
6	Lower panel	1
7	14 Flat washers	4
8	M14 Locknuts	4
9	Swivel caster	2
10	Flat washers	16
11	M10 Locknut	16
12	M10x30 Outer hexagonal bolts	16
13	Vertical caster	2