



**OPERATOR  
AND  
MAINTENANCE  
MANUAL  
MANUAL STACKER**

**MS**



**1**  ..... **1**

**2**  ..... **3**

**3**  ..... **6**

**4**  ..... **29**

**5**  ..... **31**

**6**  ..... **32**



1

<b>Characteristics</b>			
1.1	Manufacturer (Abbreviation)		ULMA Inoxtruck
1.2	Manufacturer's model designation		MS100
1.4	Operator type: manual, pedestrian, operator standing, seated		Manual
1.5	Load capacity	Q kg	100
1.6	Load center distance	c mm	450
1.10	Chassis		AISI 304L
1.11	Sheet		AISI 304L
<b>Weight</b>			
2.1	Truck weight with nominal load & maximum battery weight	kg	270
2.2	Axle loading nominal load & maximum battery weight, drive/load side	kg	75/95
2.3	Axle loading without load & maximum battery weight, drive/load side	kg	47/23
<b>Wheels and Drive Train</b>			
3.1	Tyres: P=Polyurethane, PA=Polyamide (nylon), Vul=Vulkollan, drive/load side		P / P
3.2	Tyre dimensions, drive side		80 X 20
3.3	Tyre dimensions, load side		125 X 32
3.5	Number of wheels, drive/load side (x=driven)		2 + 2
3.6	Track width (center of tyres), drive side	b10 mm	480
3.7	Track width (center of tyres), load side	b11 mm	480
<b>Dimensions</b>			
4.2	Height with mast lowered	h1 mm	1995
4.4	Lift height	h3 mm	1410
4.5	Overall height with mast raised	h4 mm	1995
4.15a	Fork height, fully lowered	h13 mm	140
4.15b	Fork height, fully extended	h12 mm	1550
4.19	Overall length	l1 mm	1120
4.20	Length to fork face	l mm	640
4.21	Overall width	b1 mm	585
4.25	Outside width over forks (minimum/maximum)	b5 mm	400
4.32	Ground clearance at center of wheelbase	m2 mm	30
4.34a	Working aisle width (Ast) with load	Ast mm	1620
4.35	Turning circle radius	Wa mm	1130

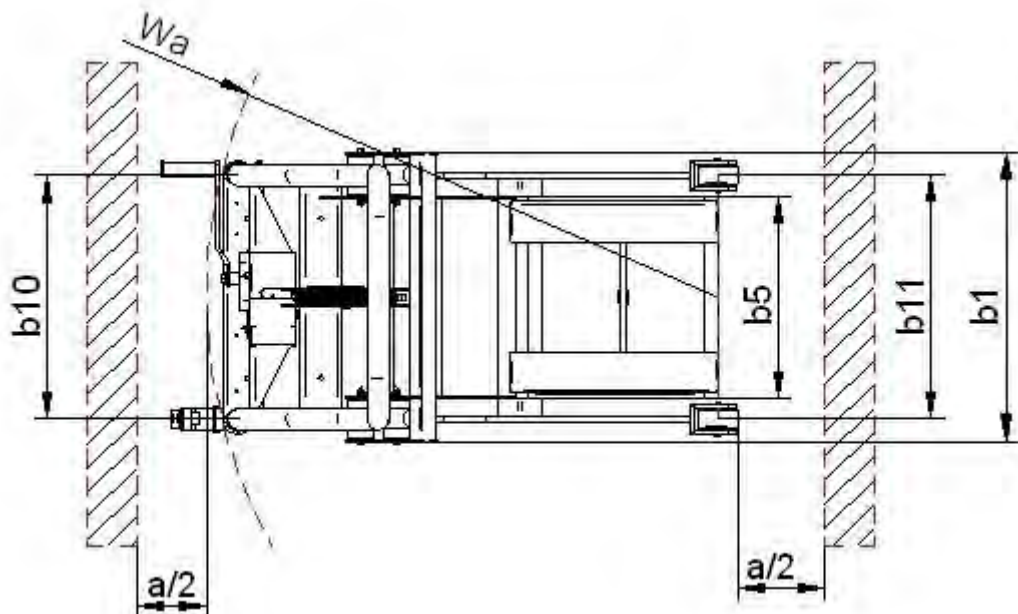
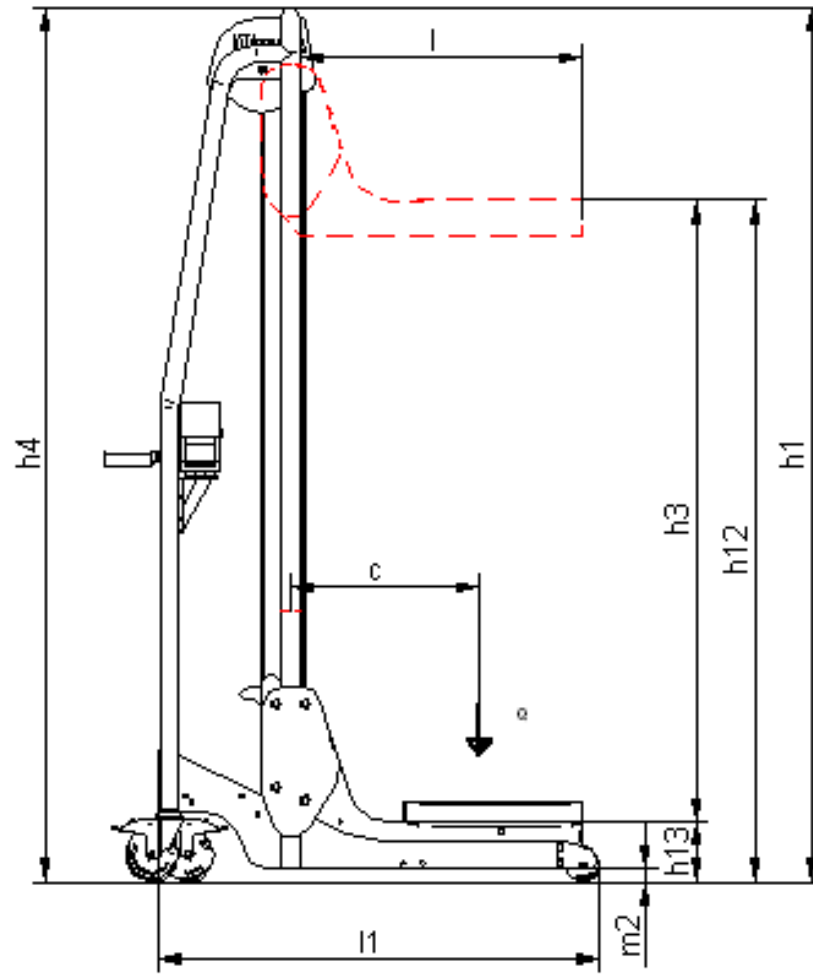

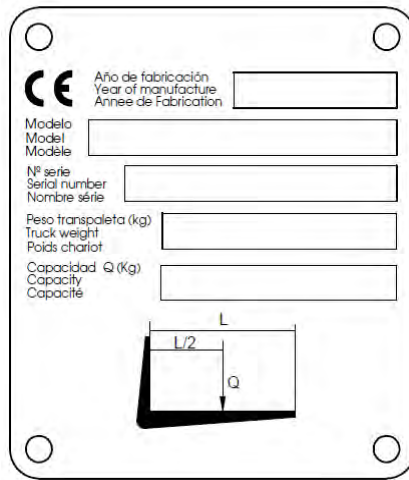

2

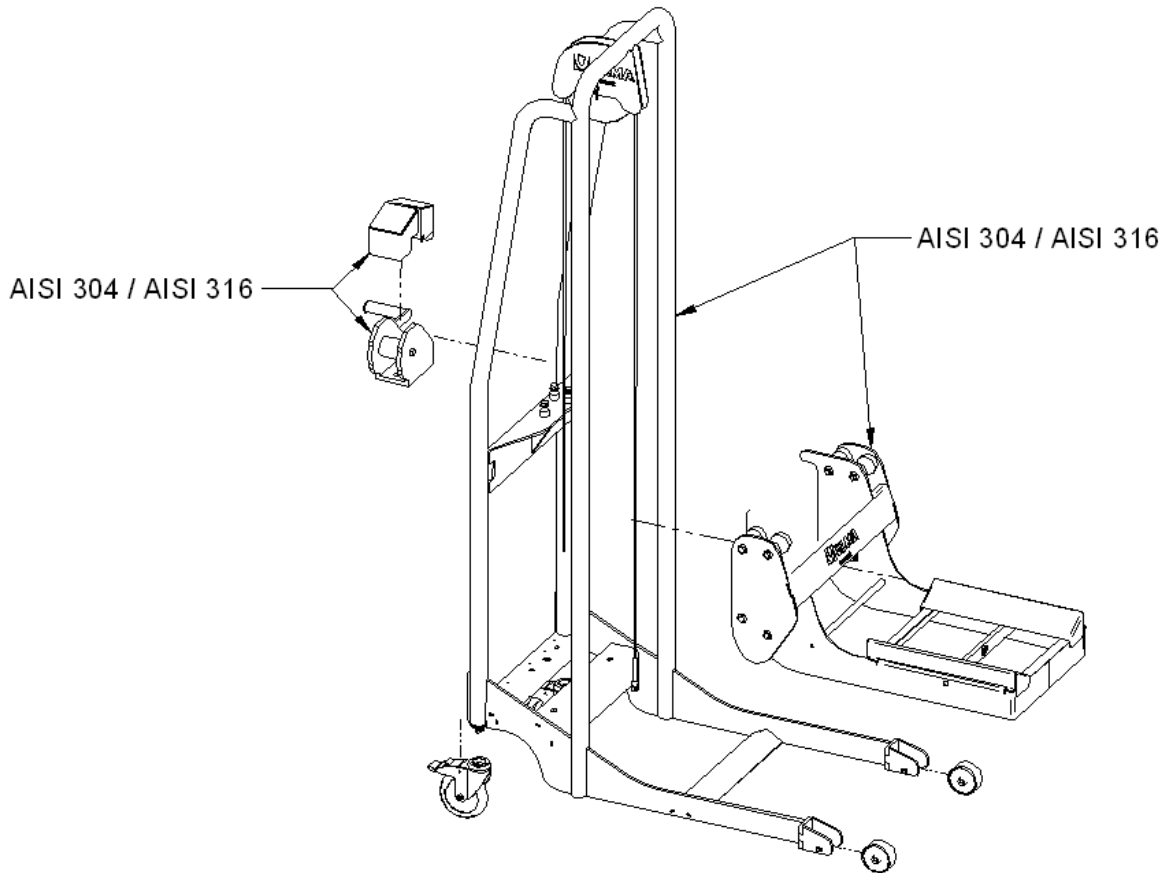

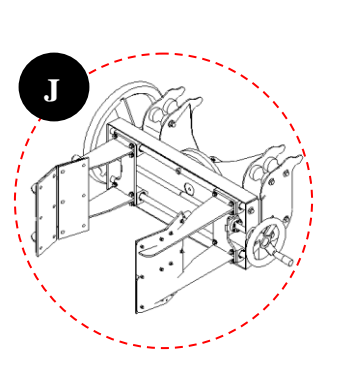
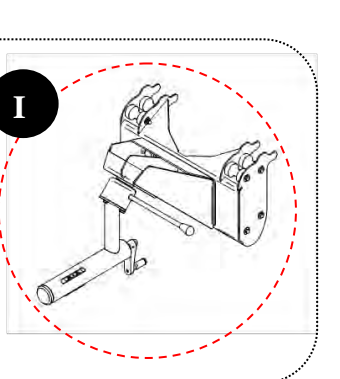
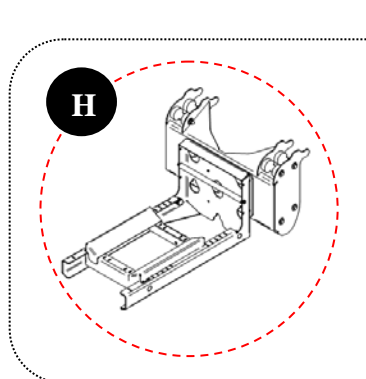
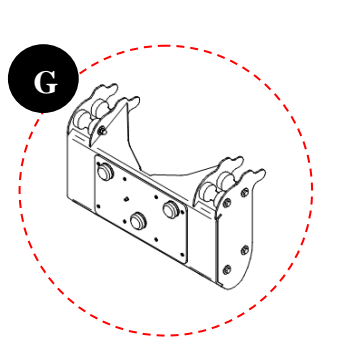
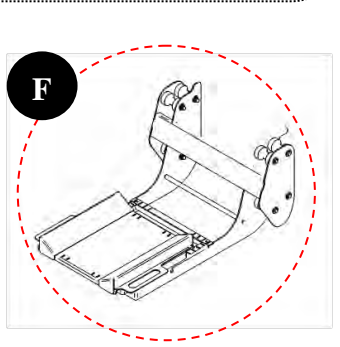
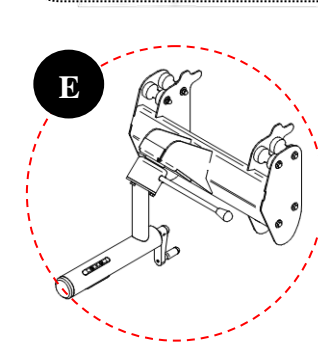
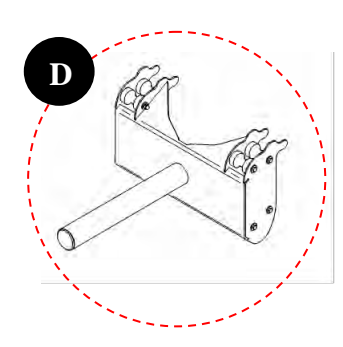
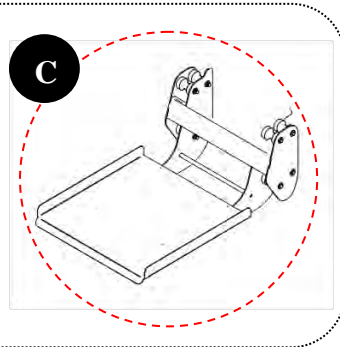
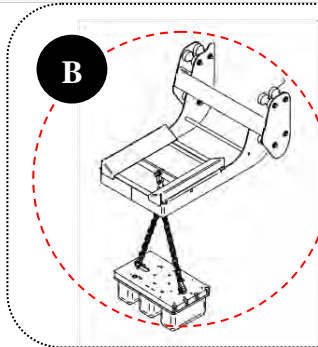
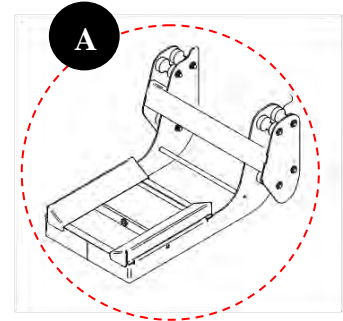
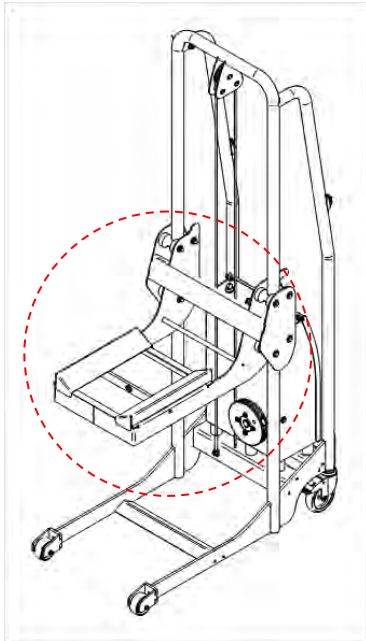

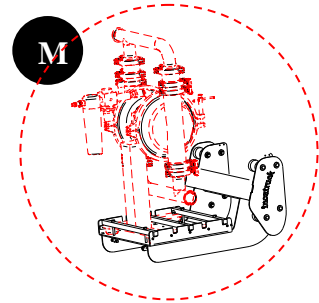
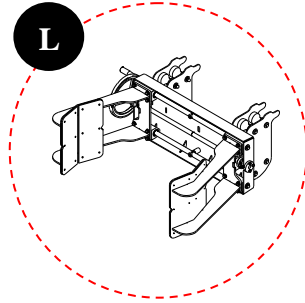
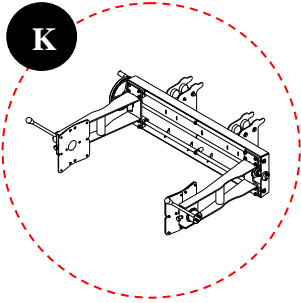

3

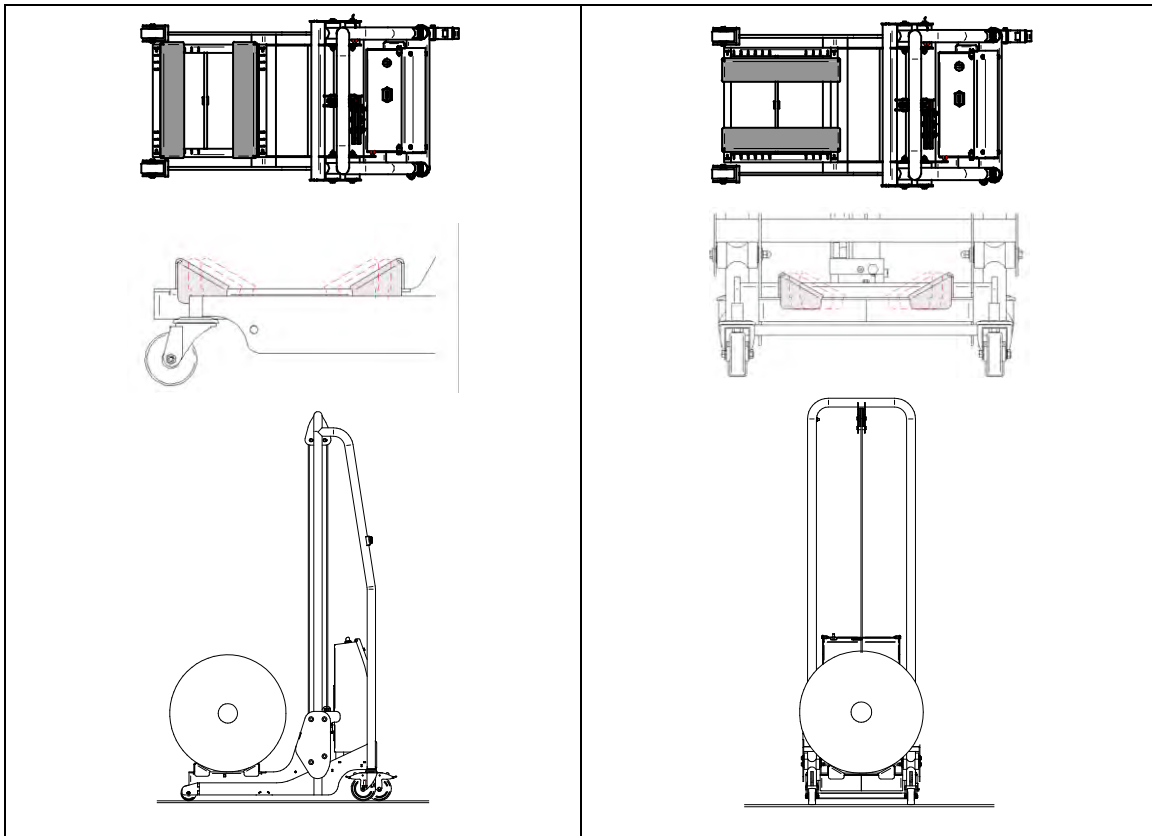
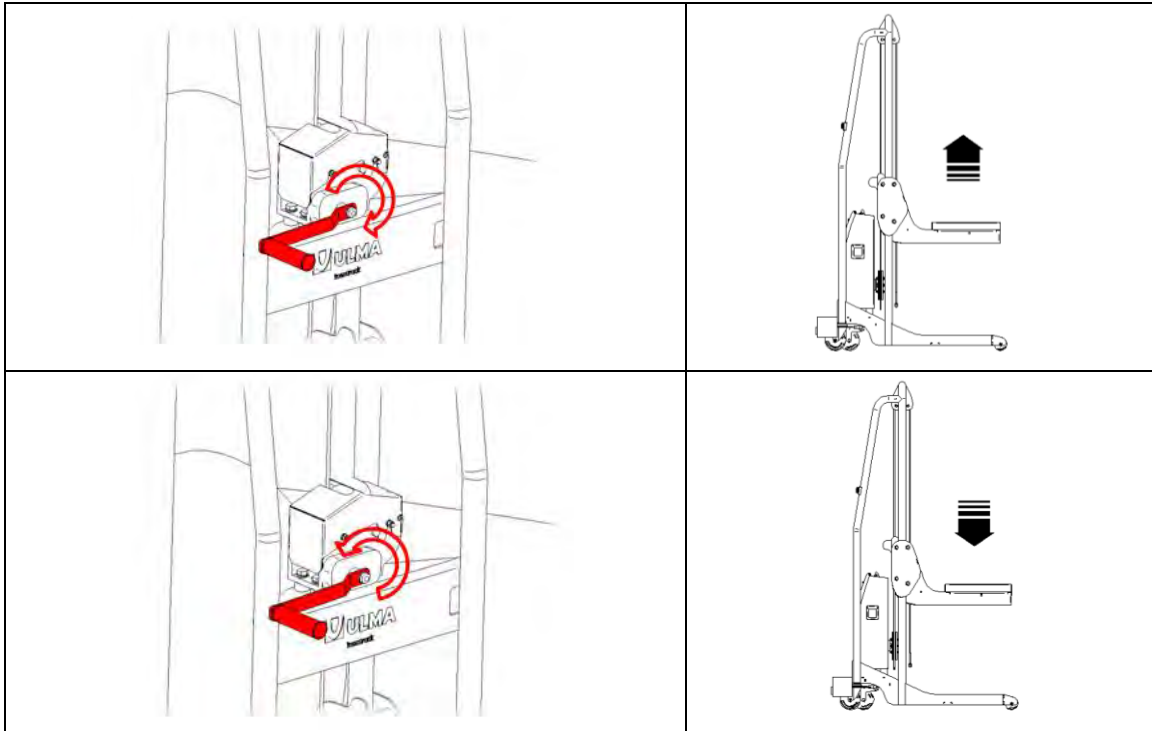

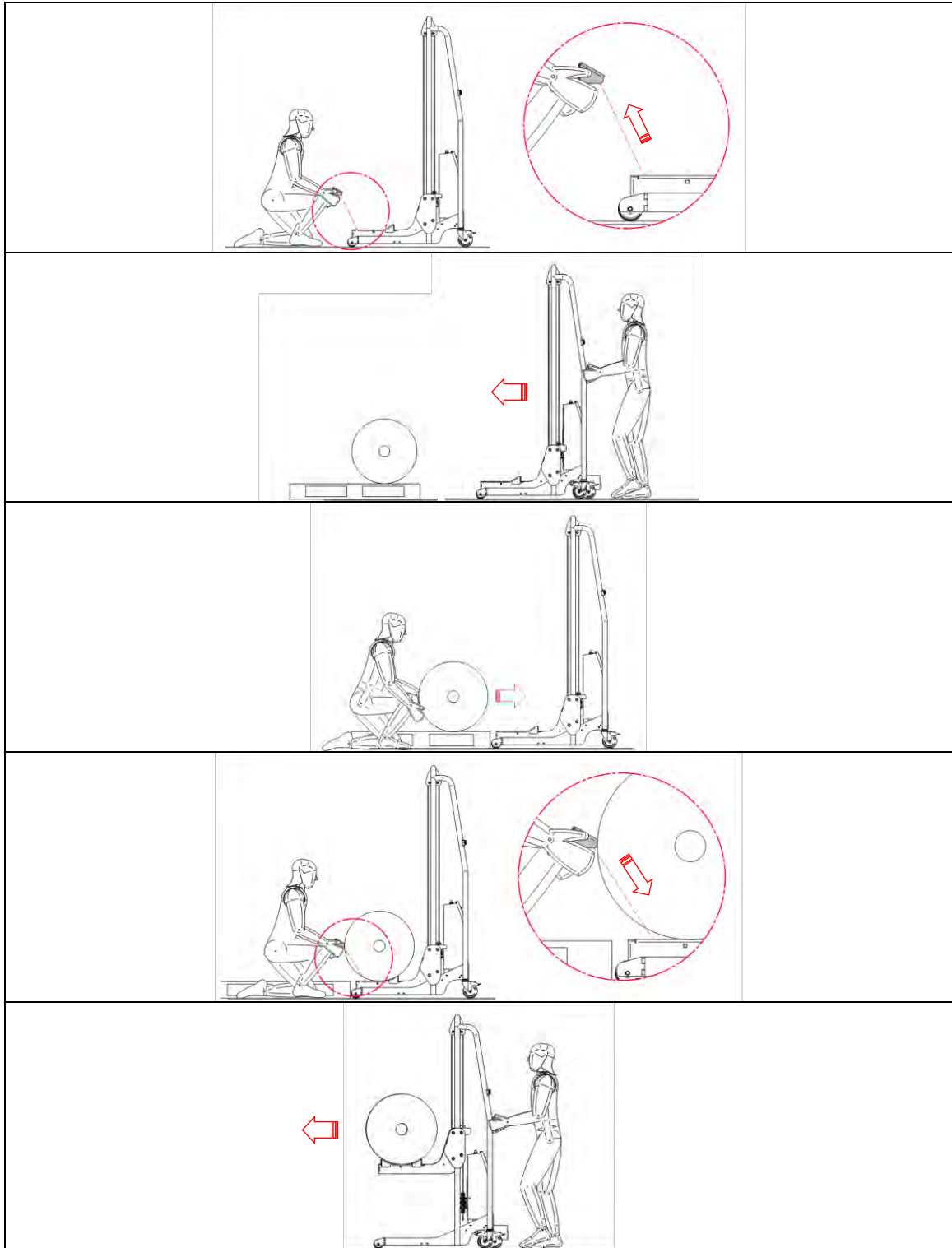
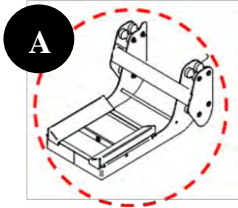

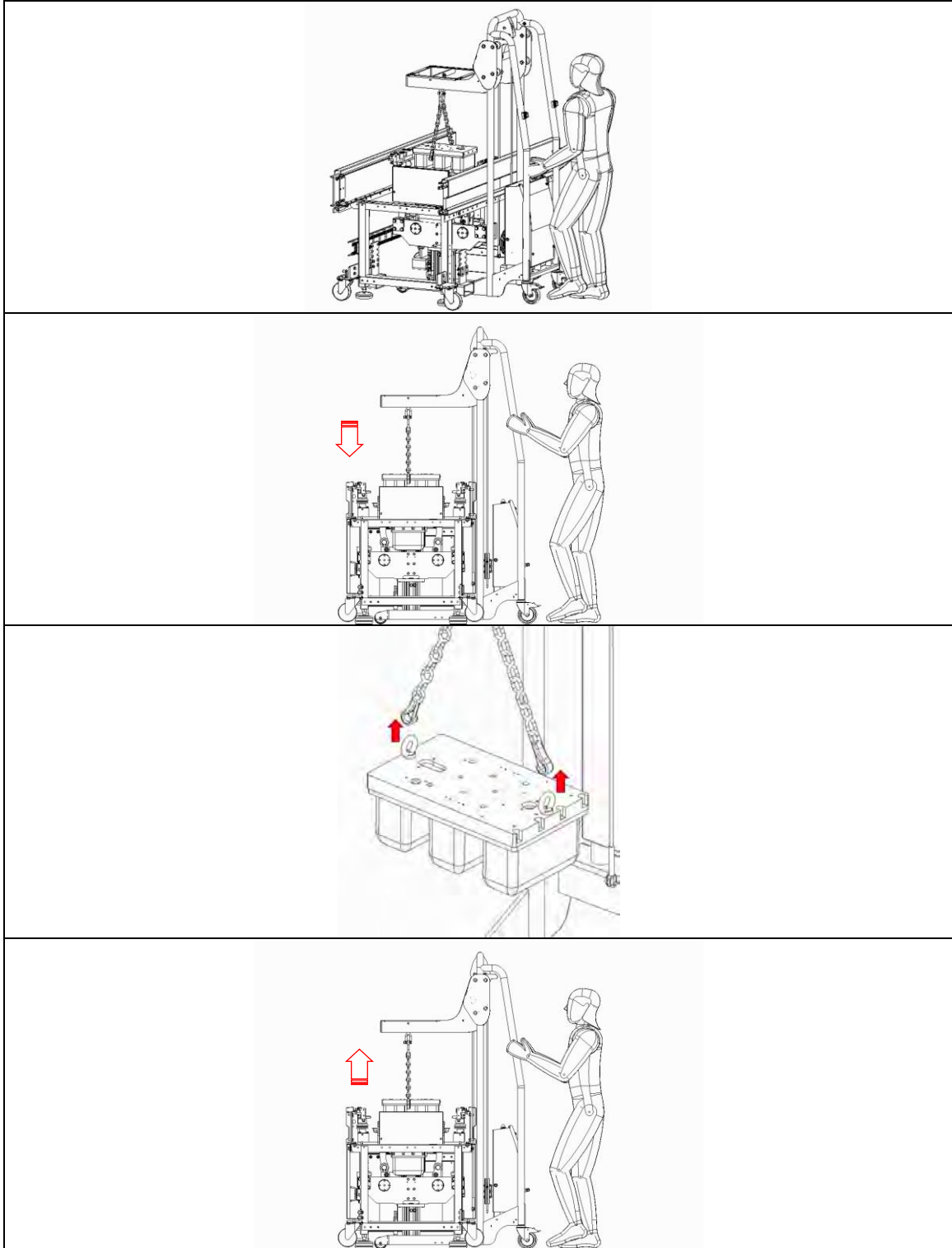
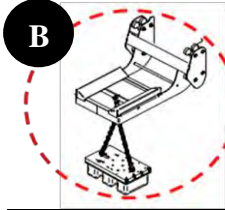

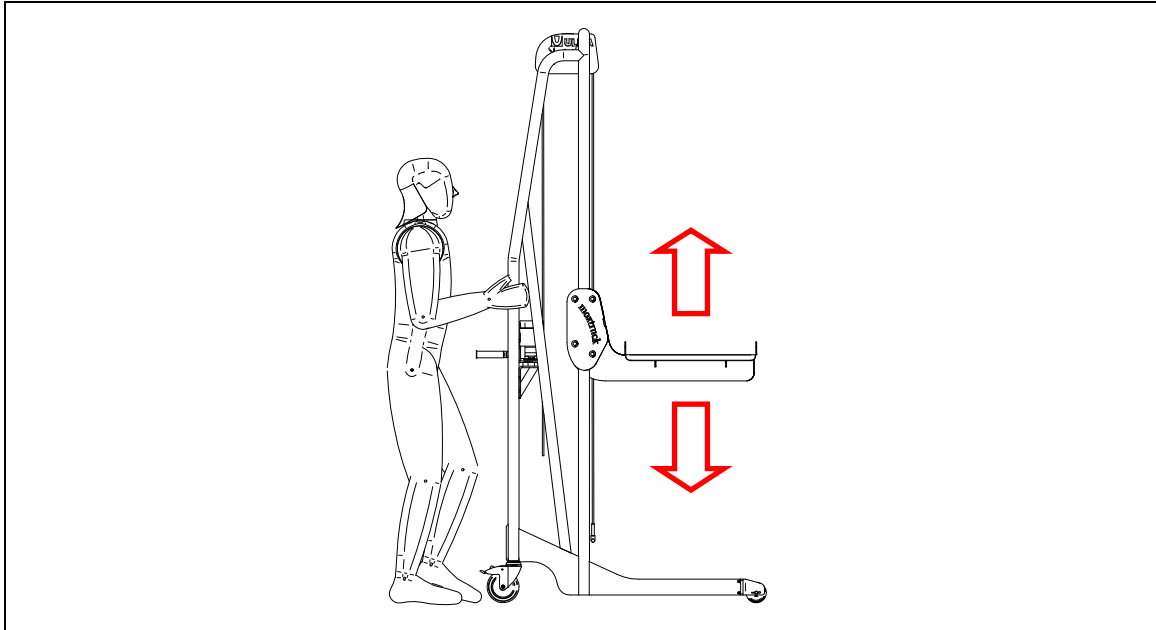
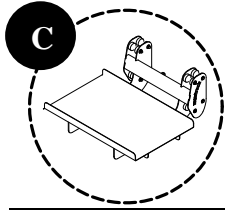

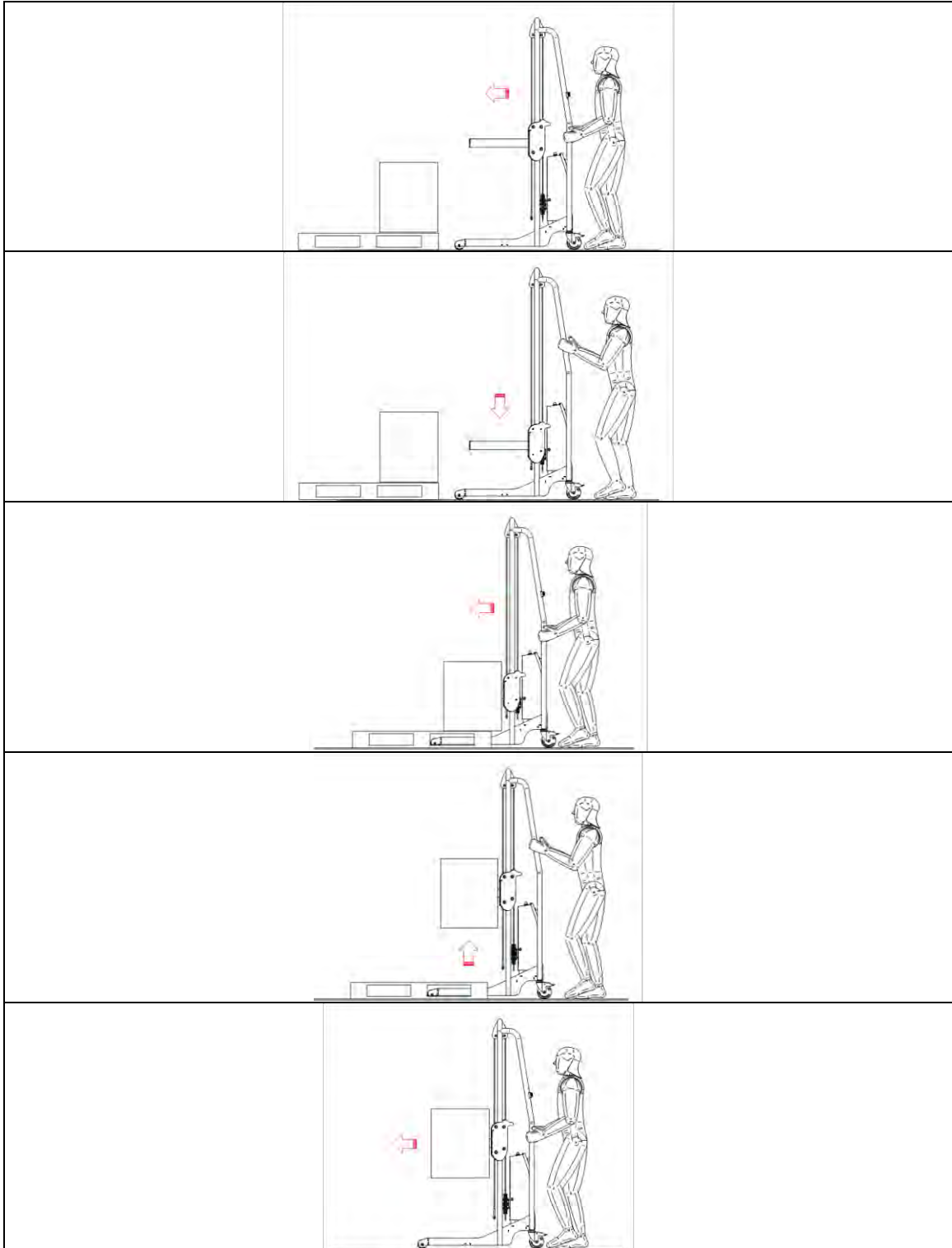
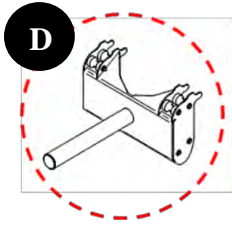

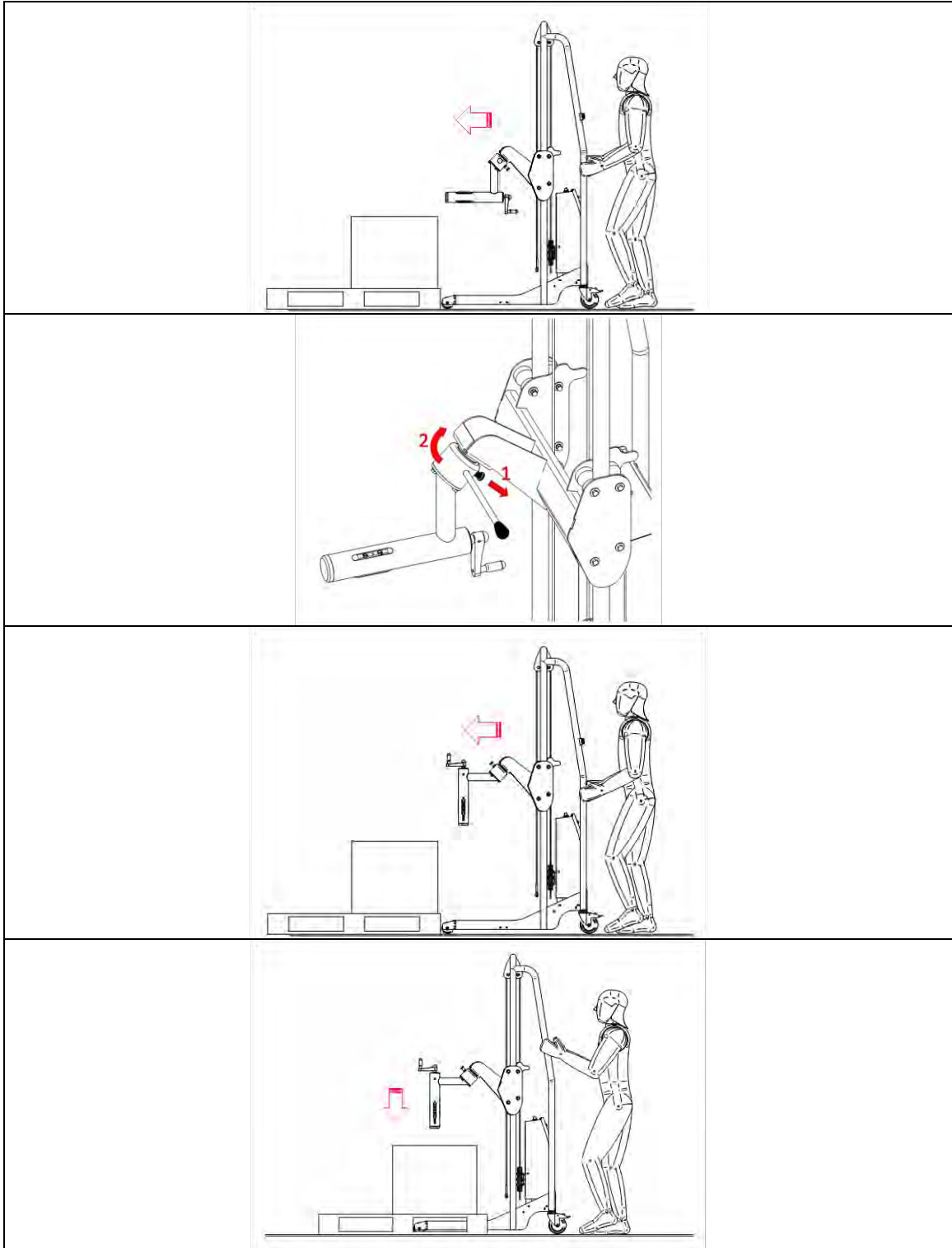
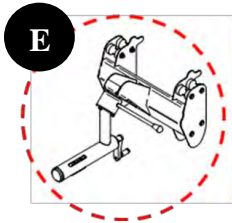

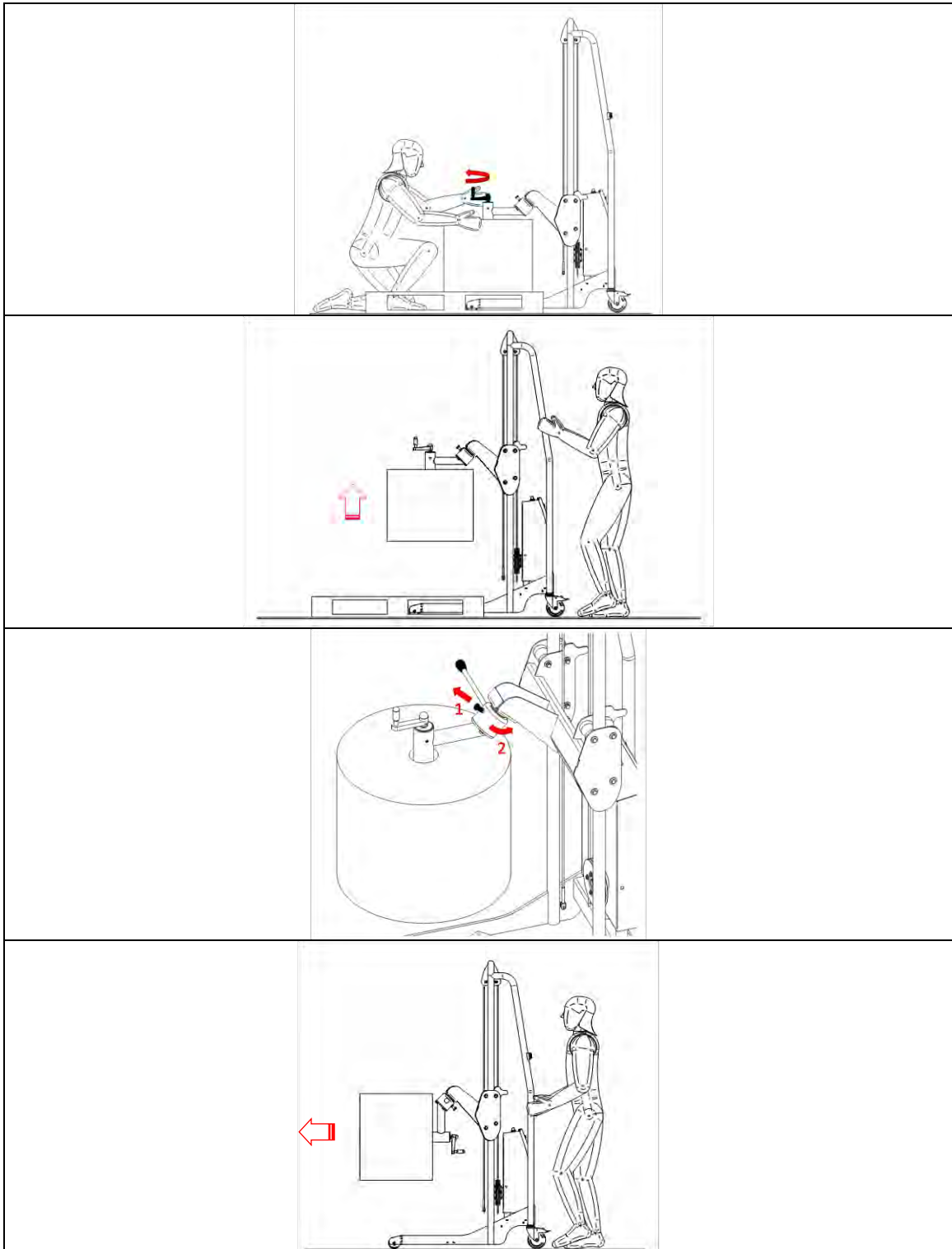

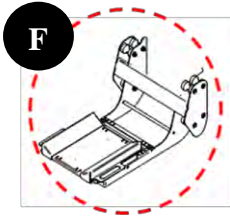

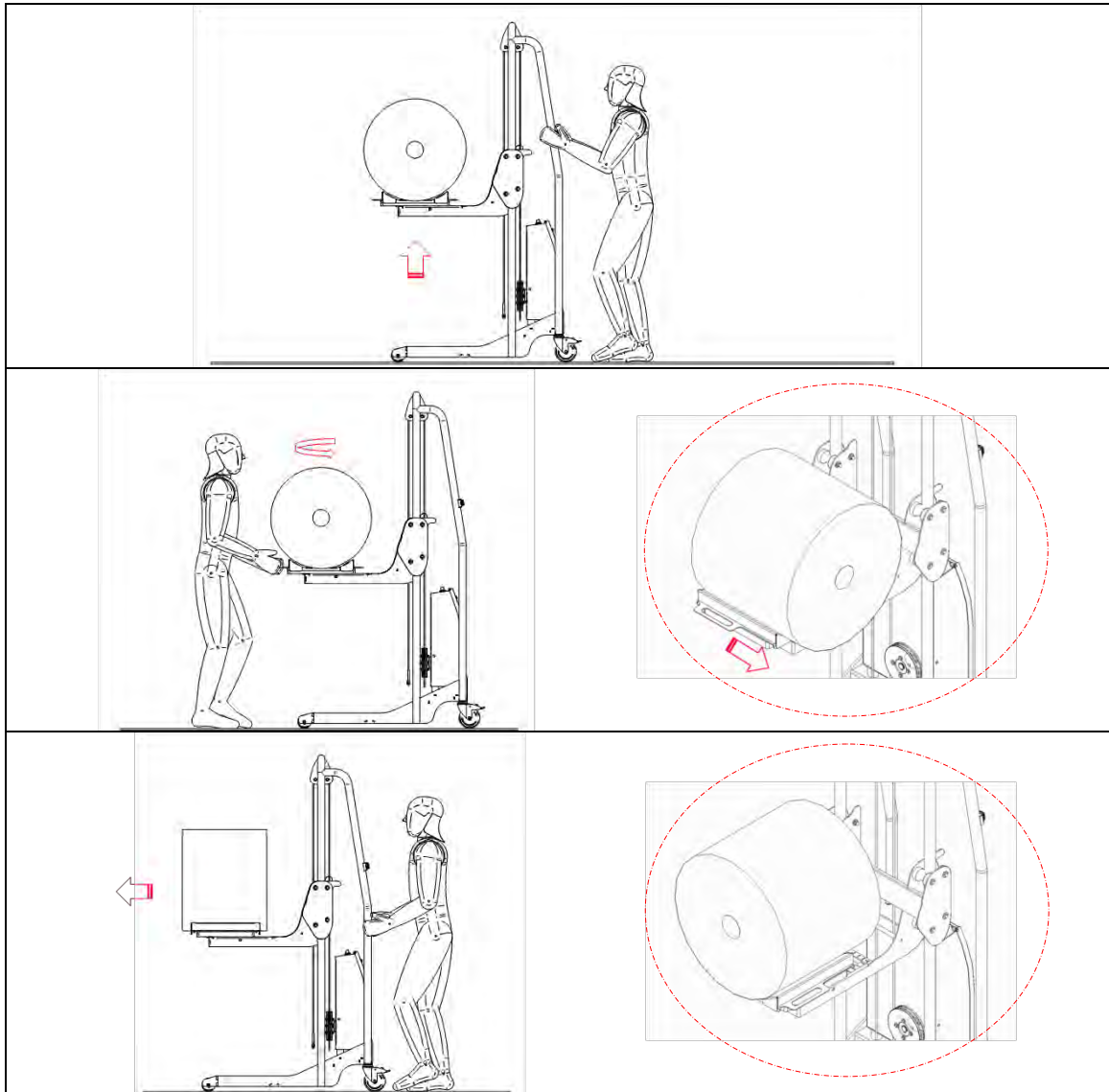

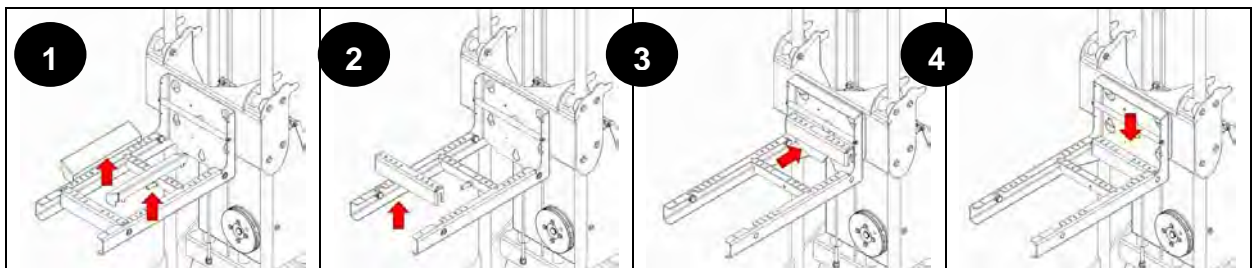
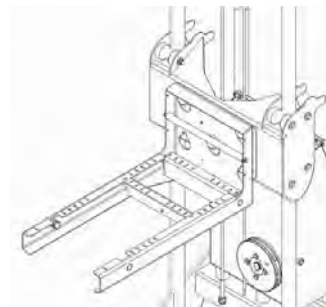
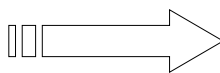
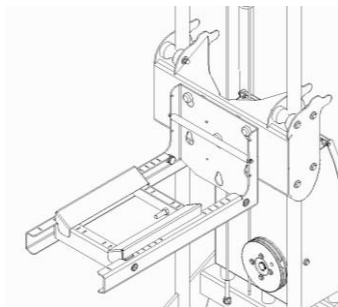
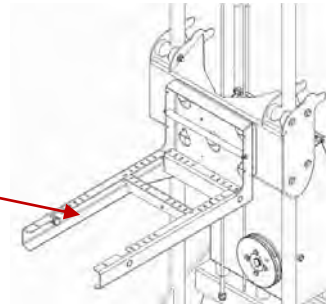
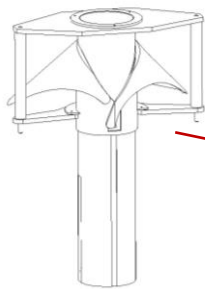
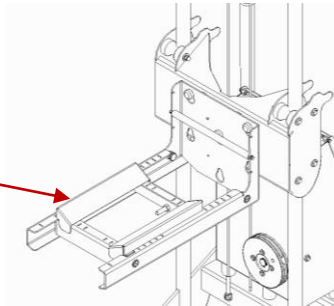
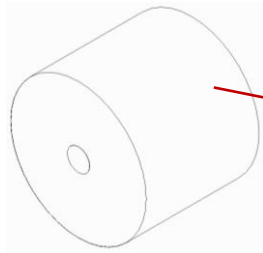
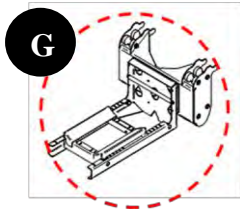

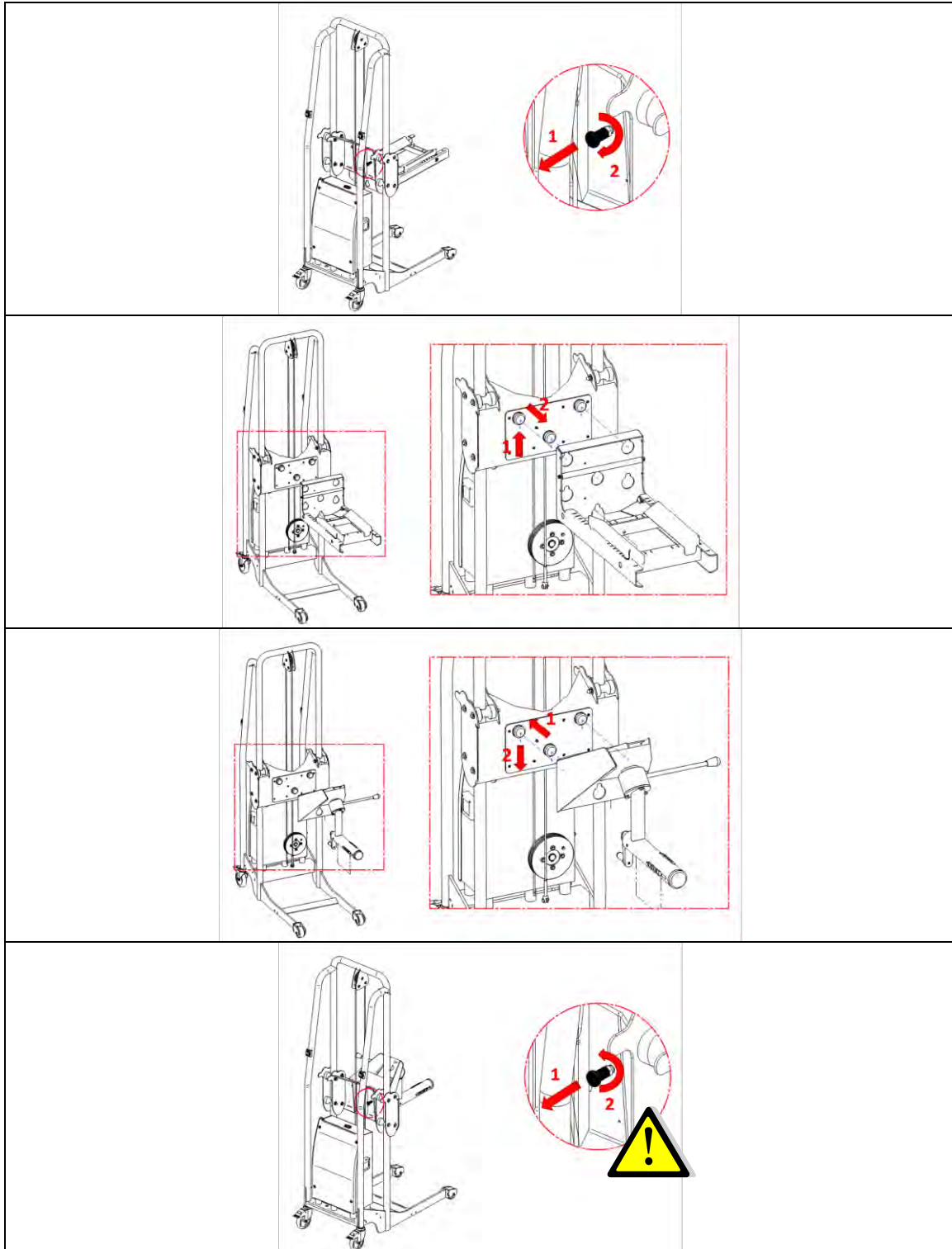
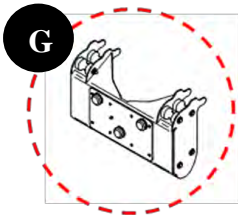

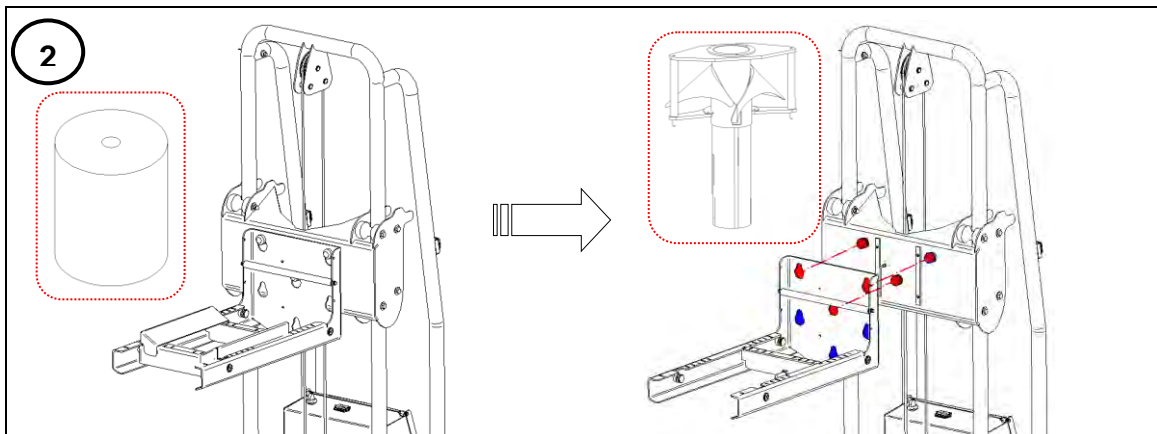
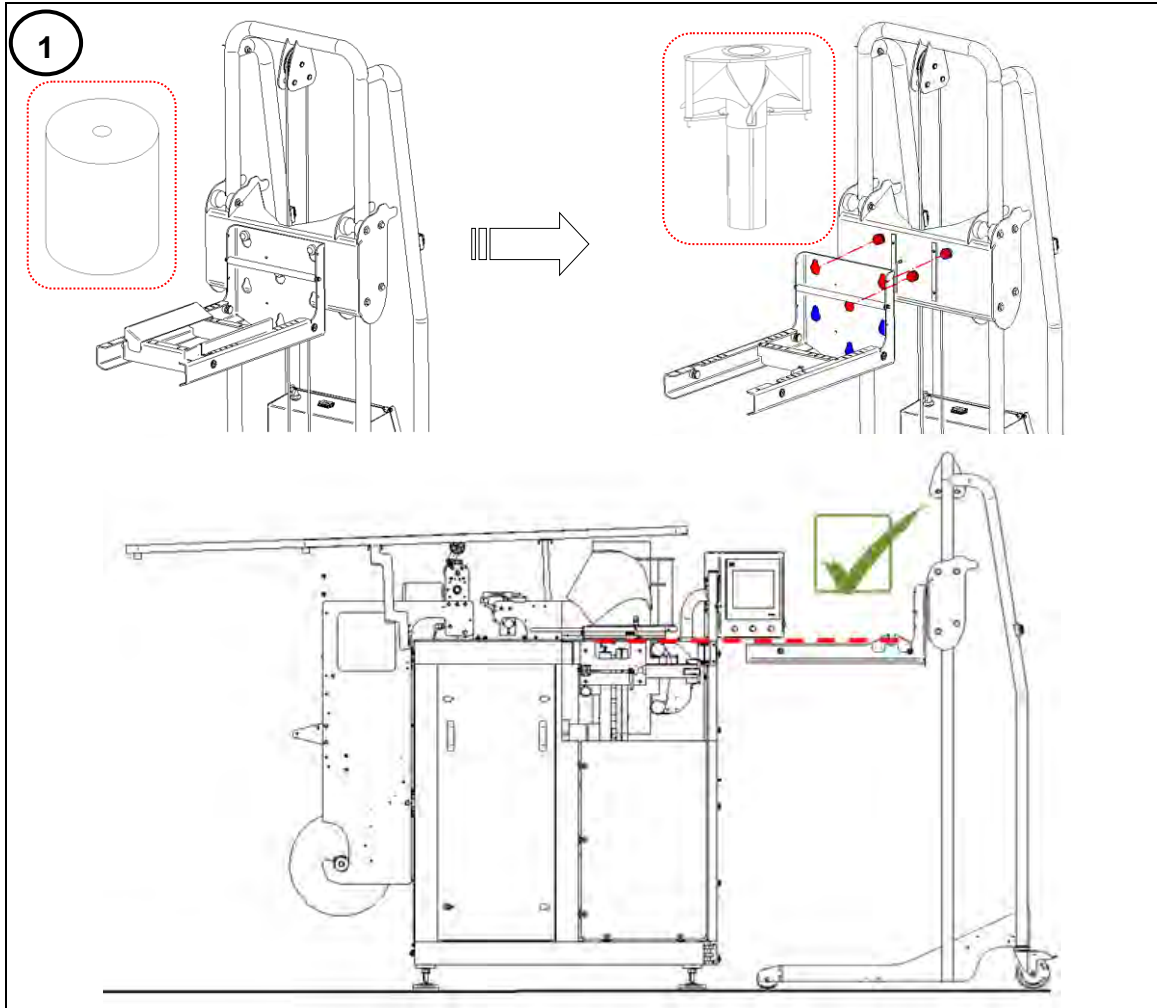
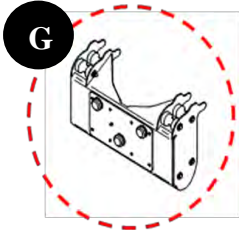

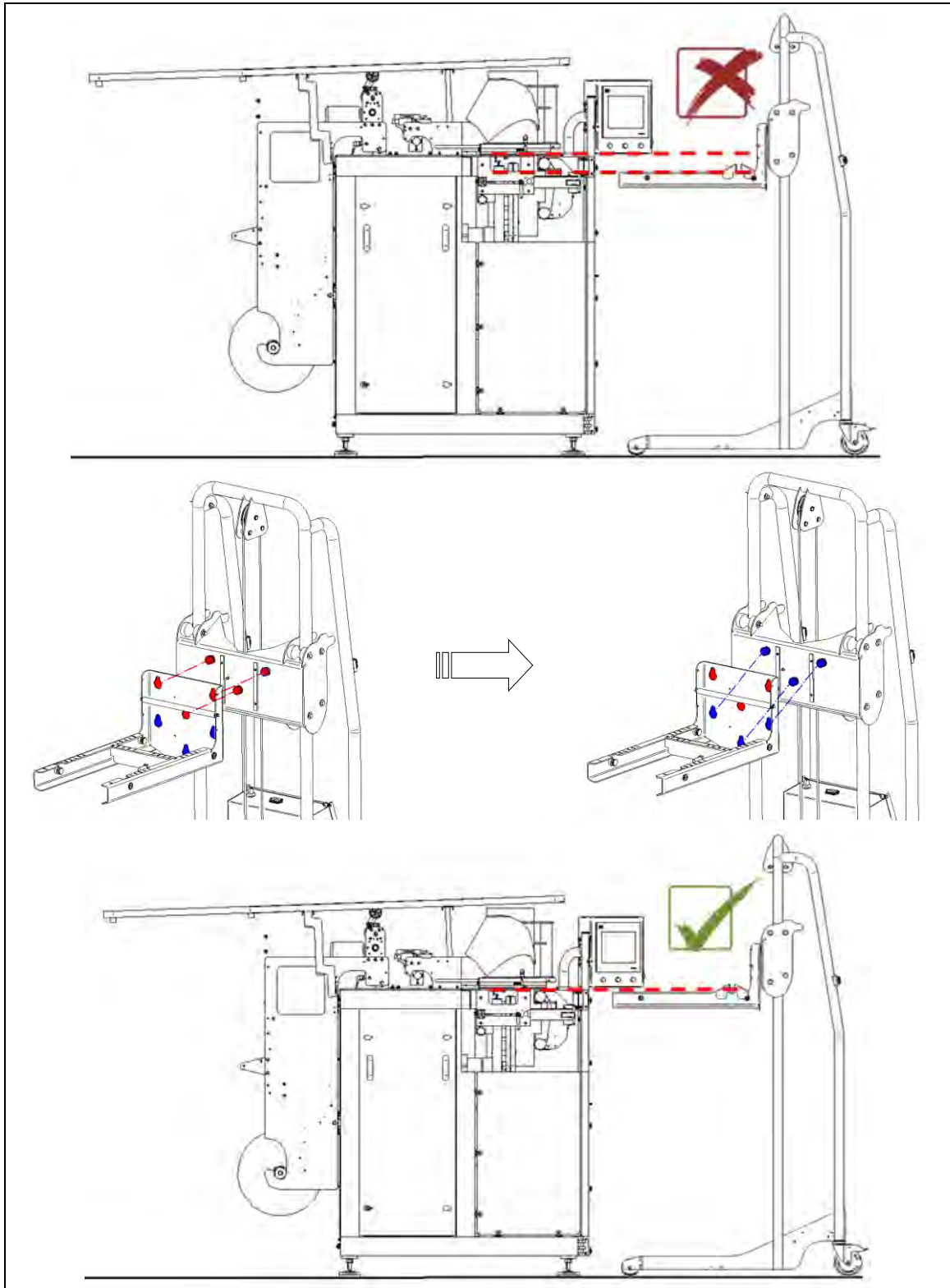

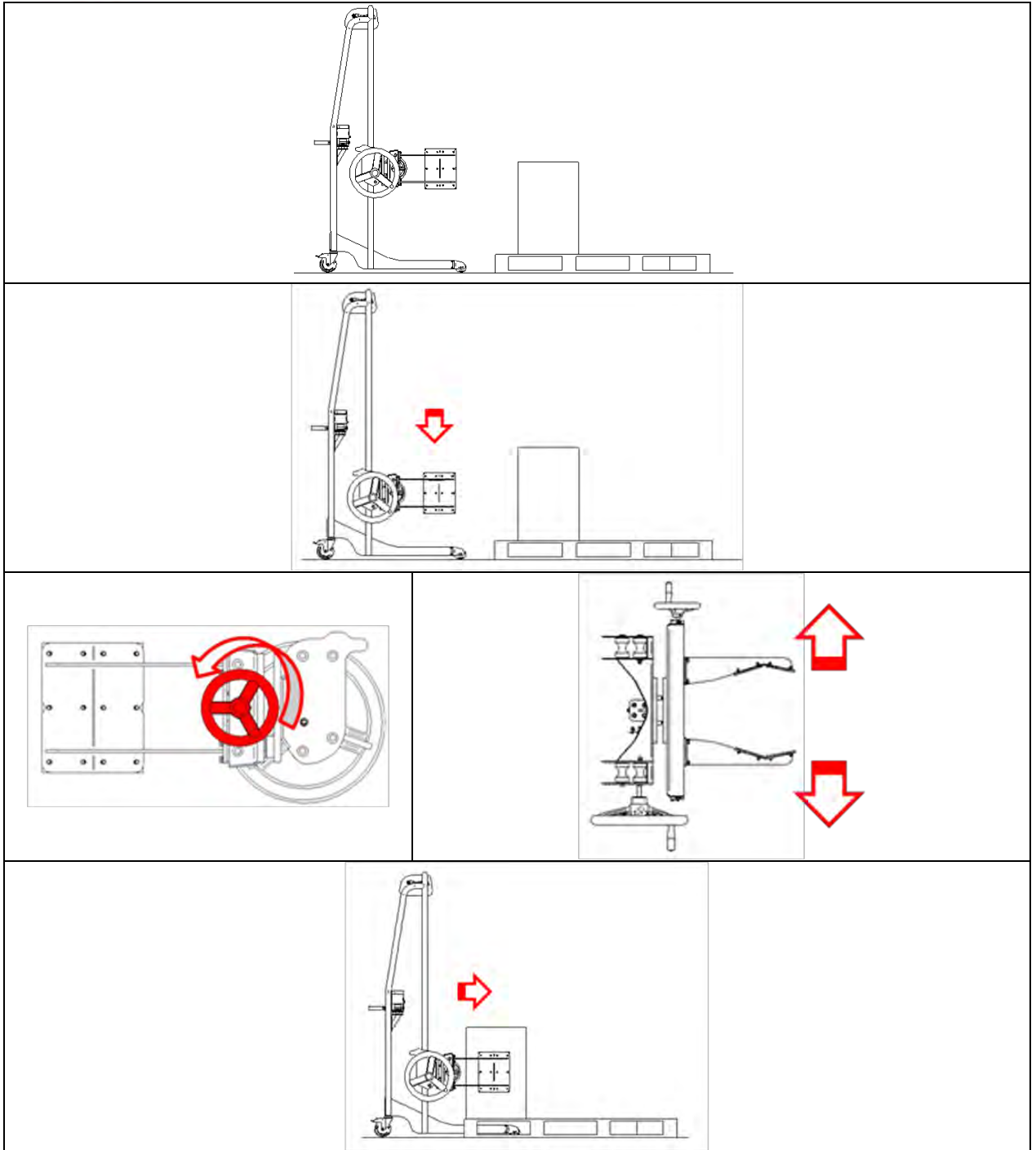
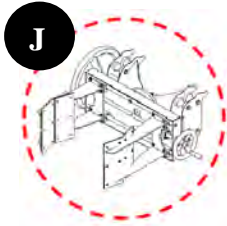

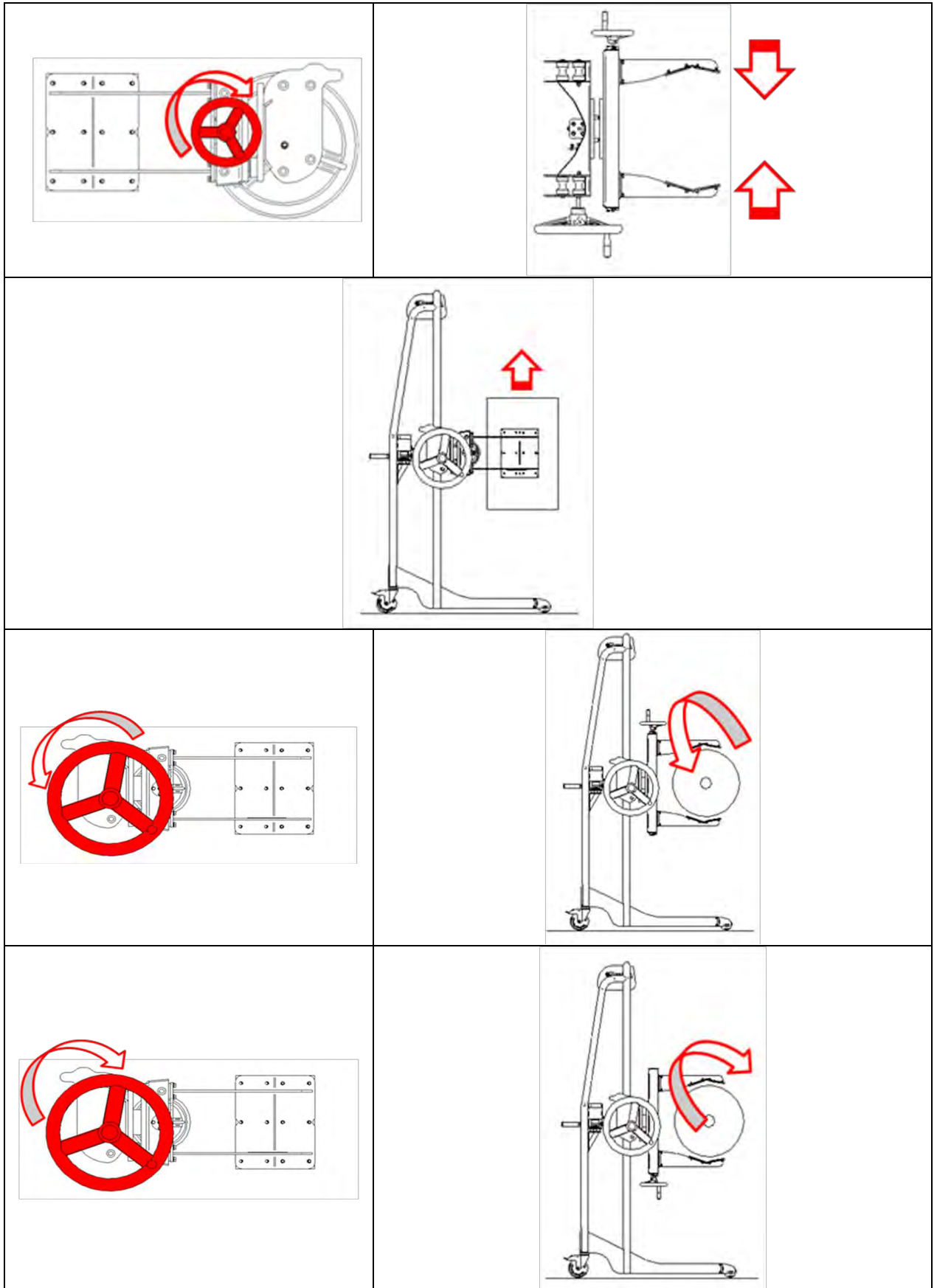

K

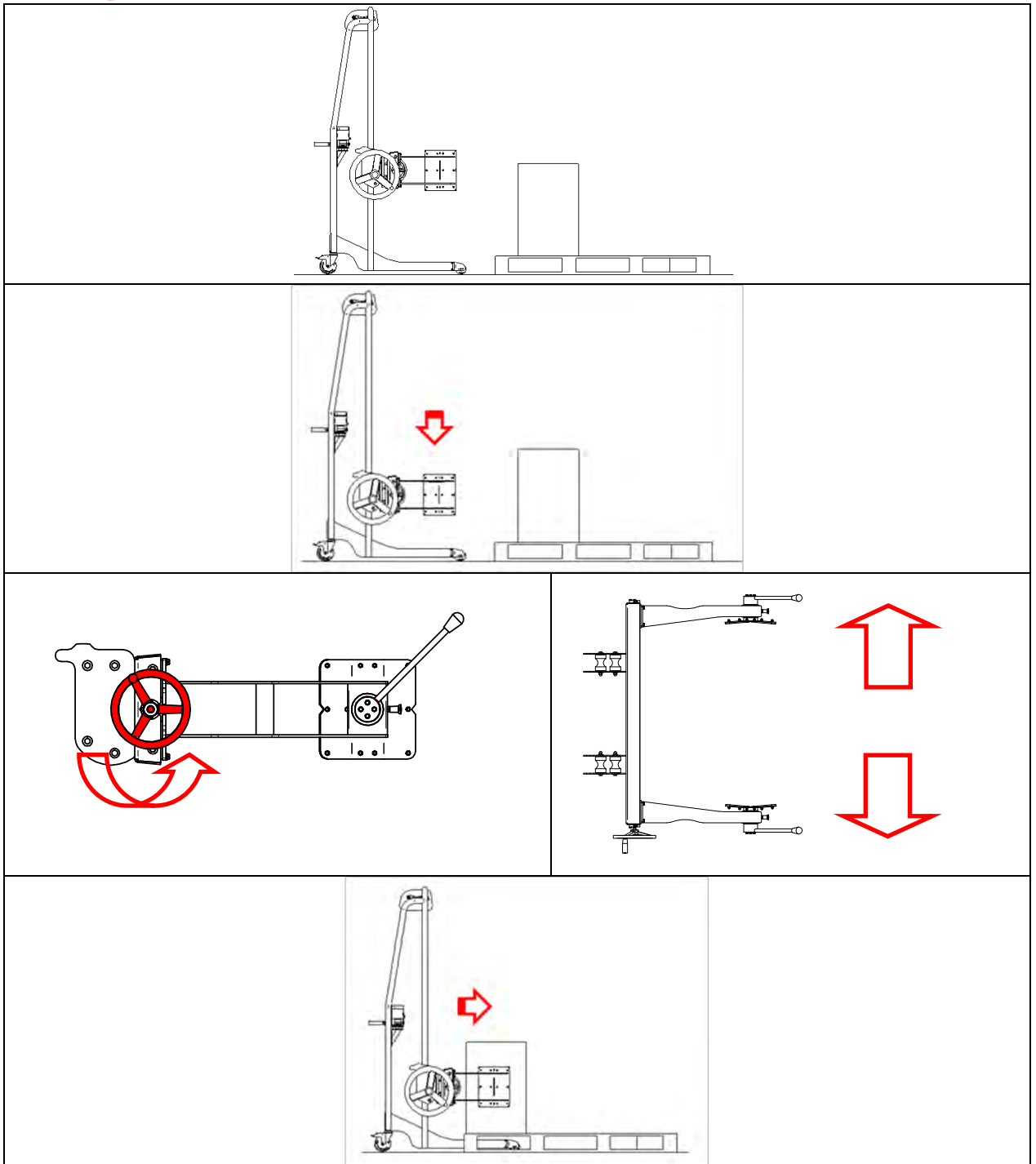
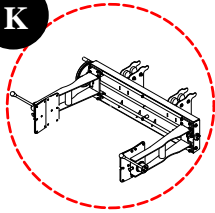

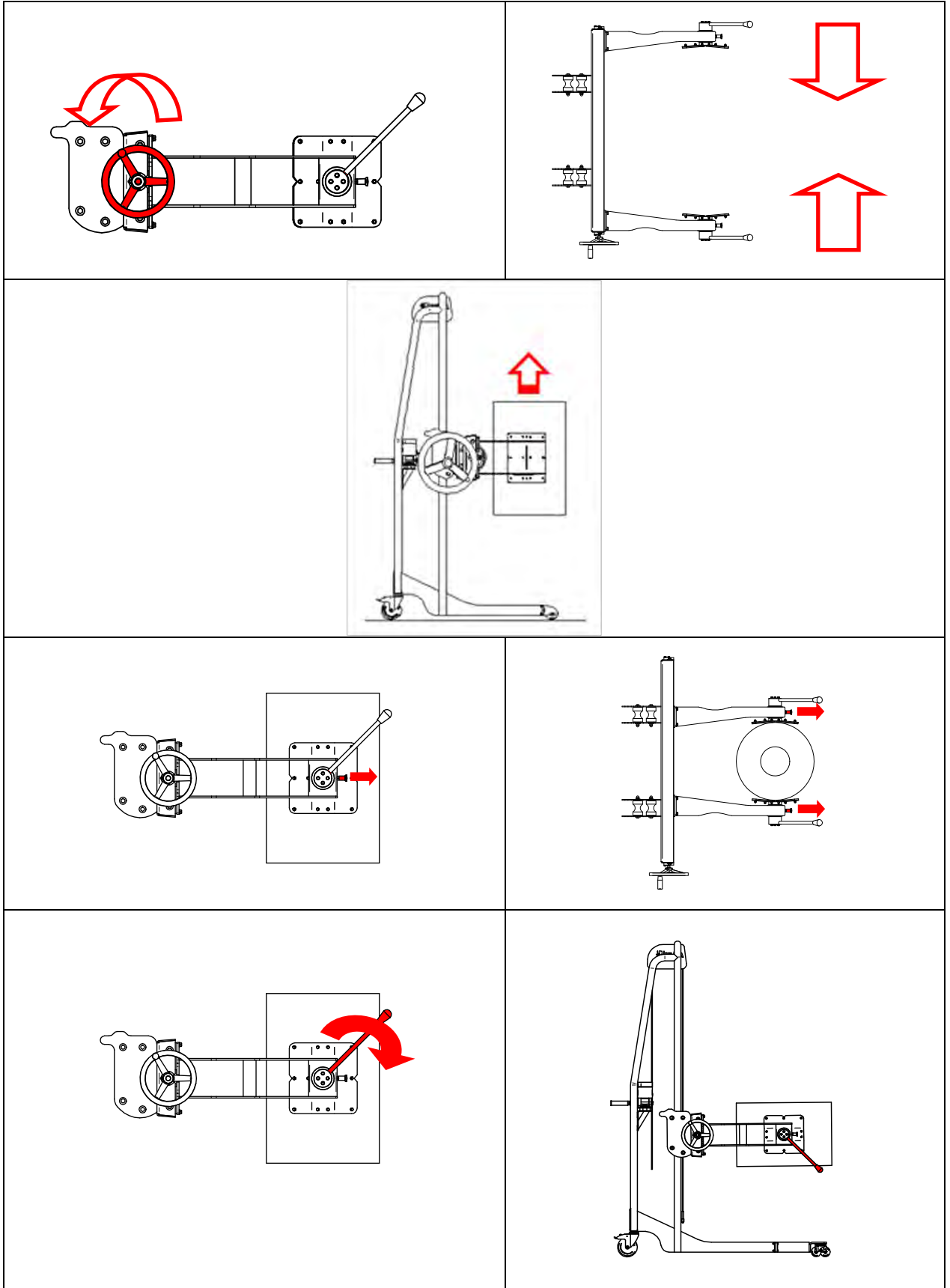

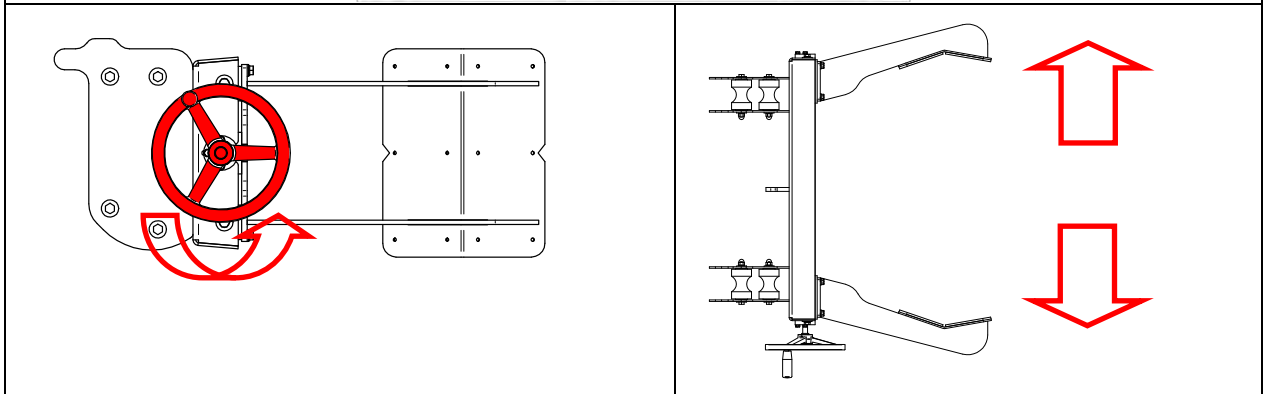
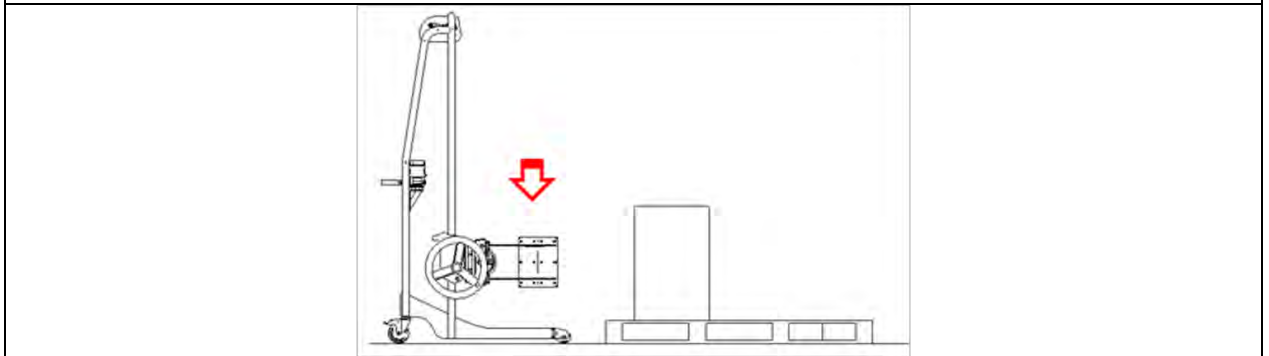
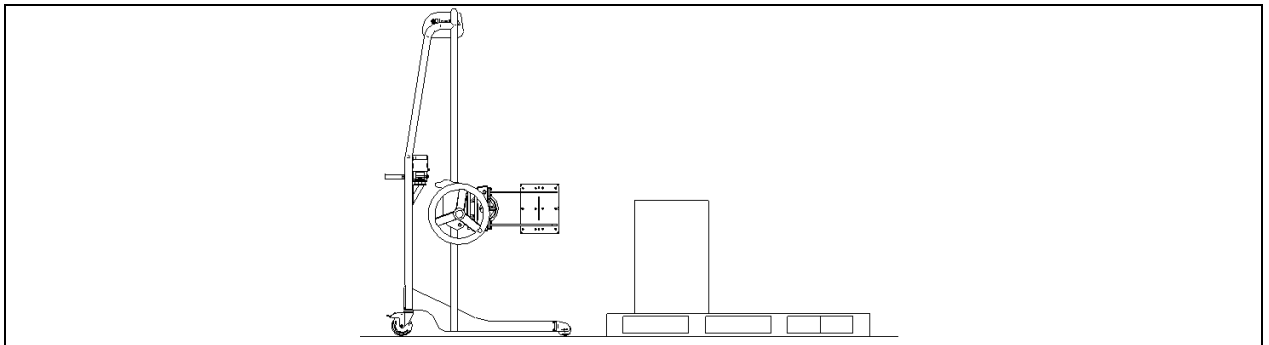
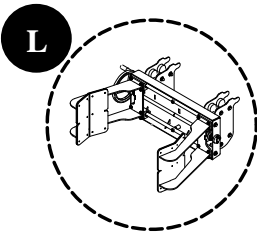
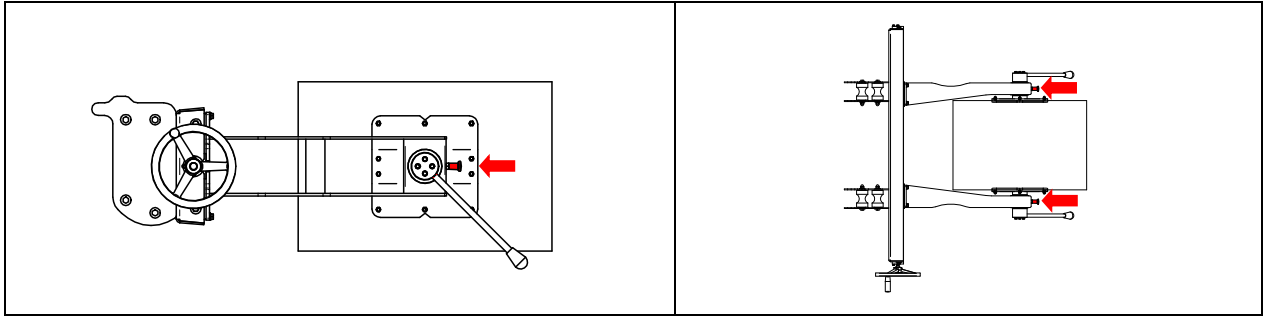

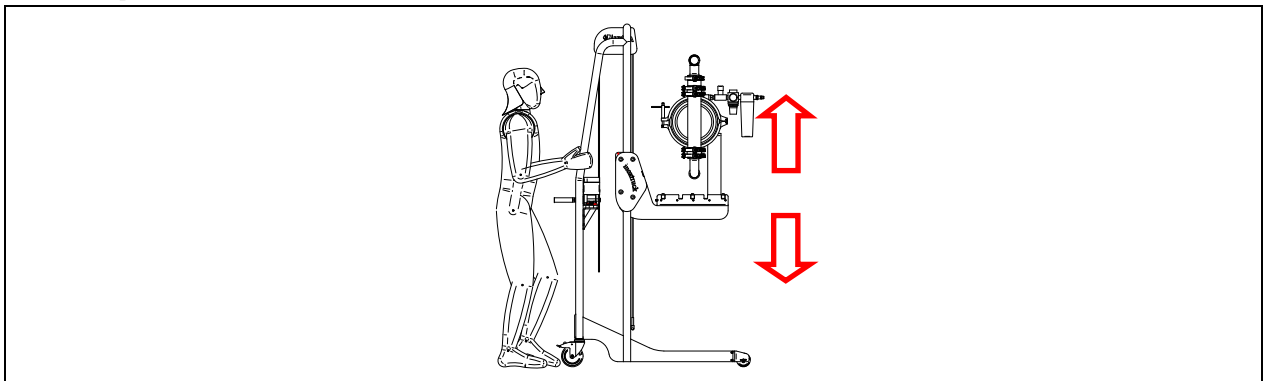
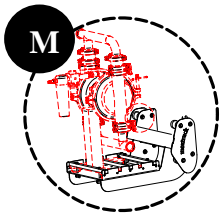
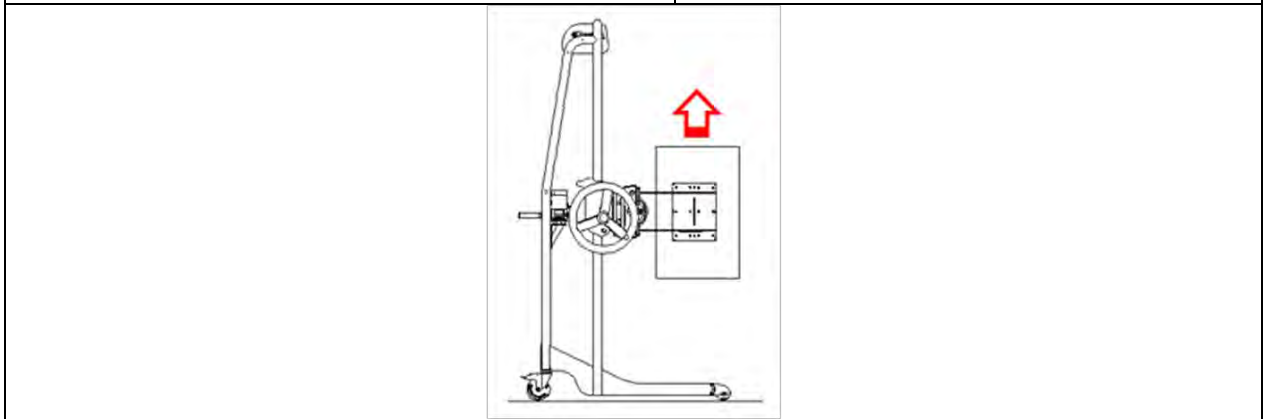
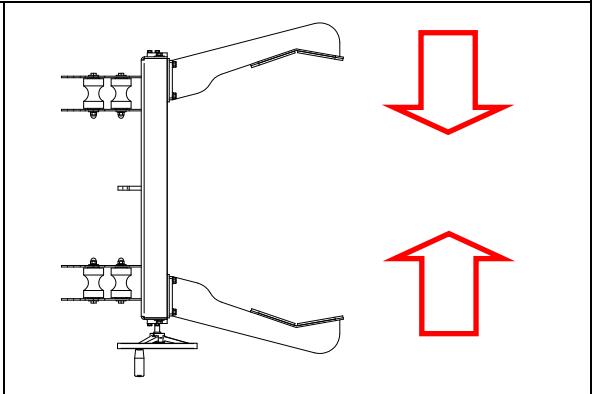
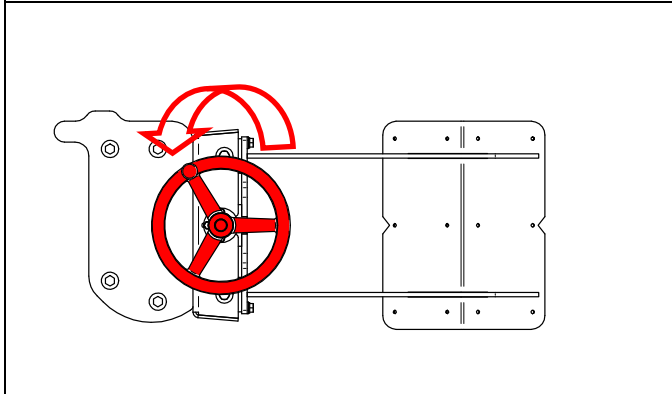
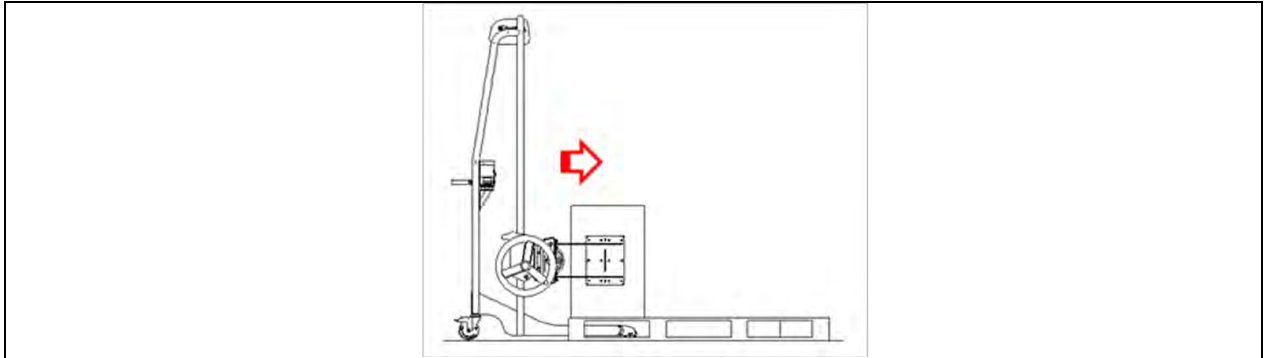

3.2

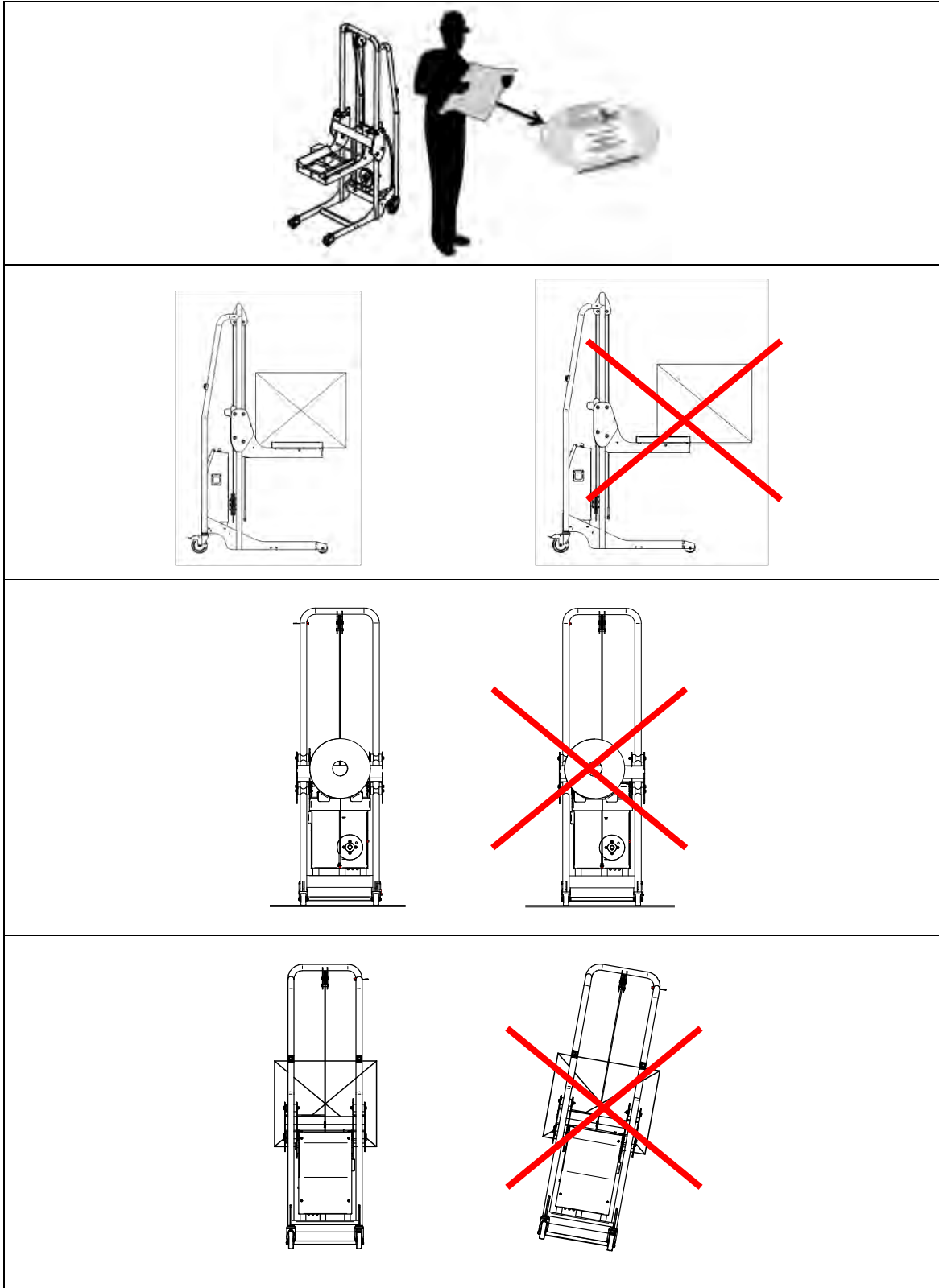

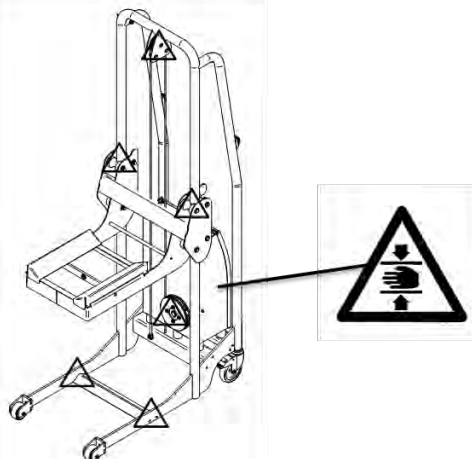
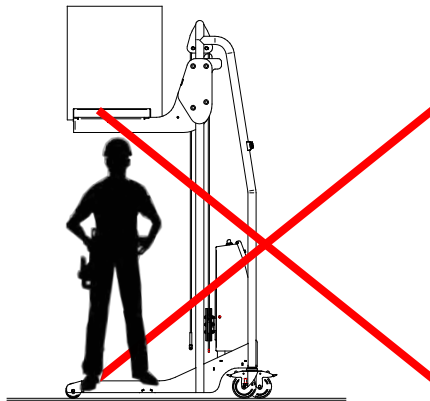
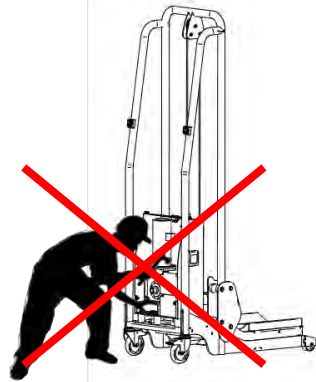
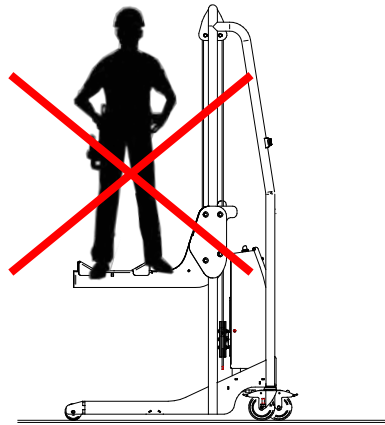



**< 76 dB**

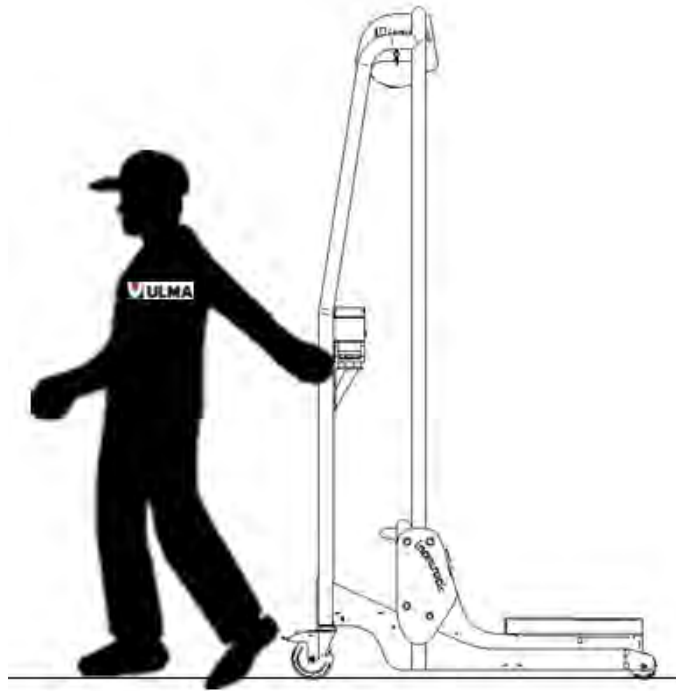

3.3

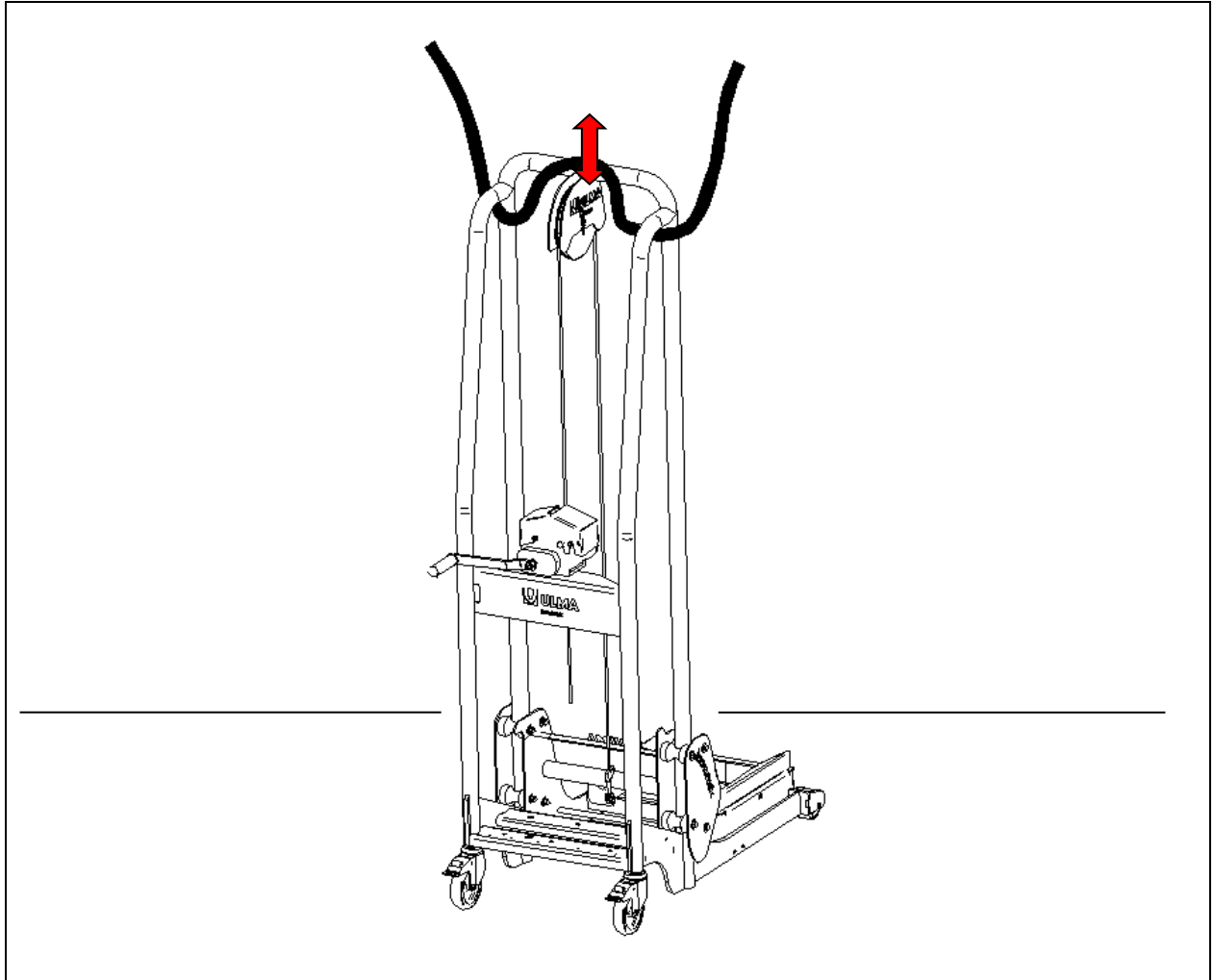

4

4.1

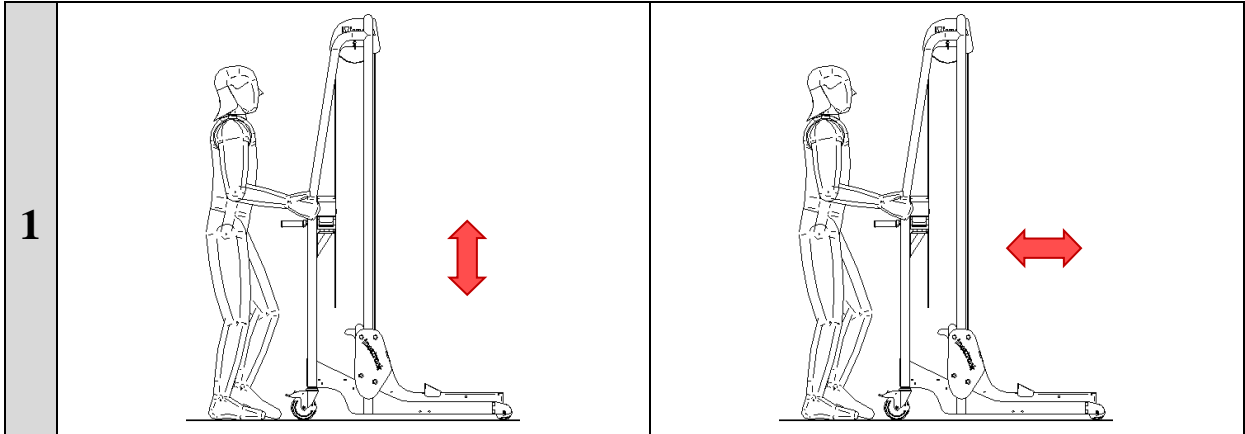

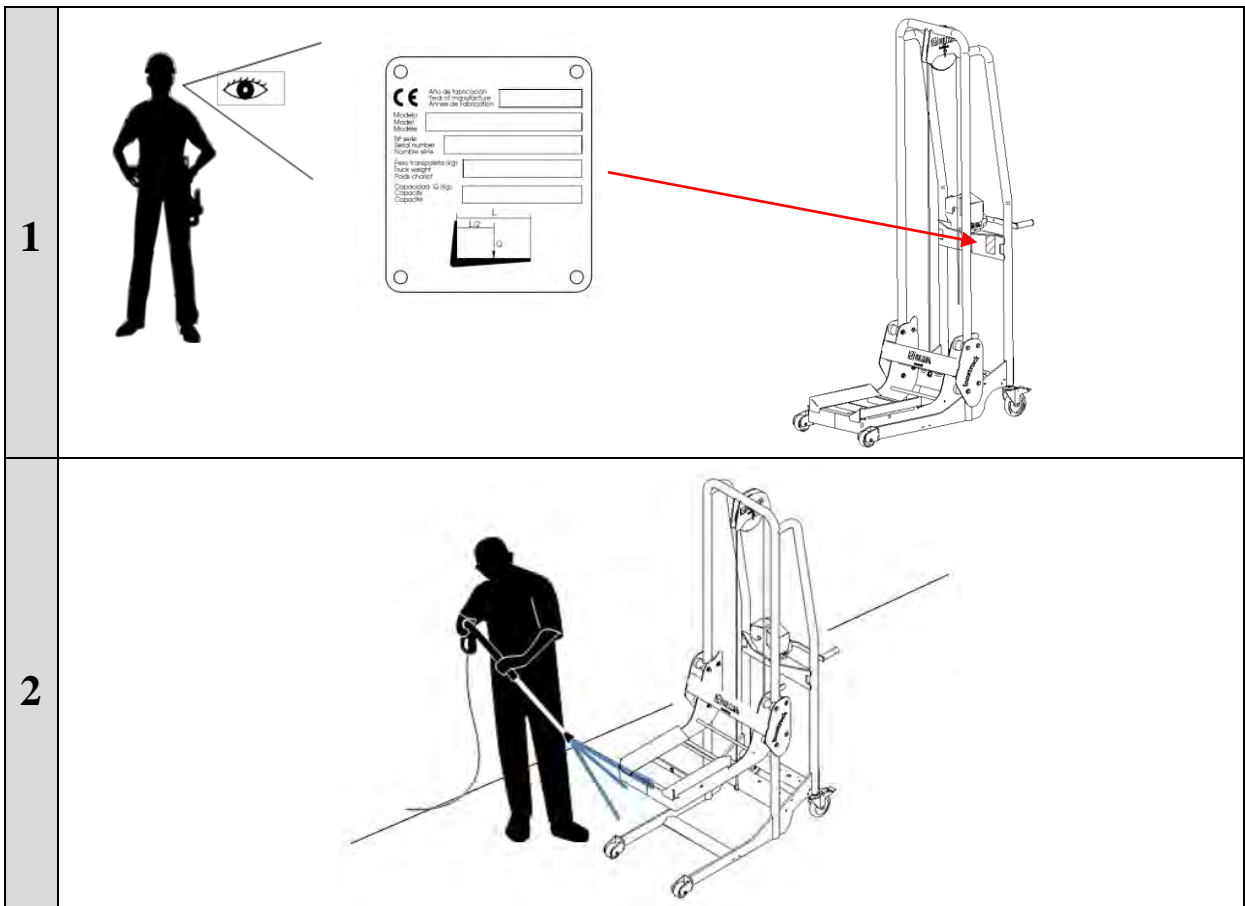

4.2

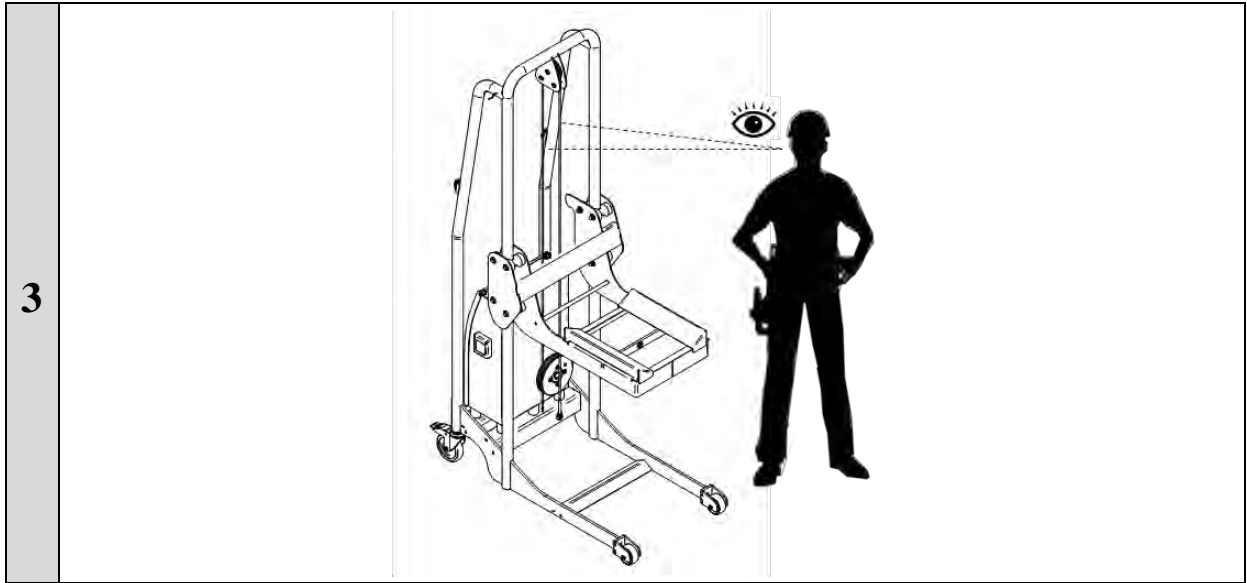

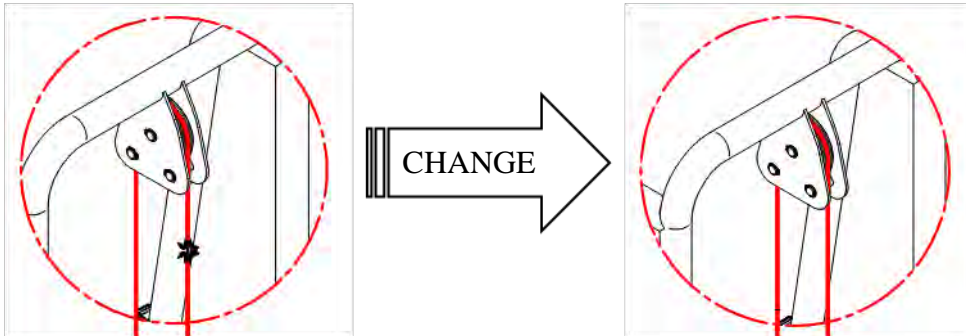

**4.3** ————— **IF IT IS DAMAGED**





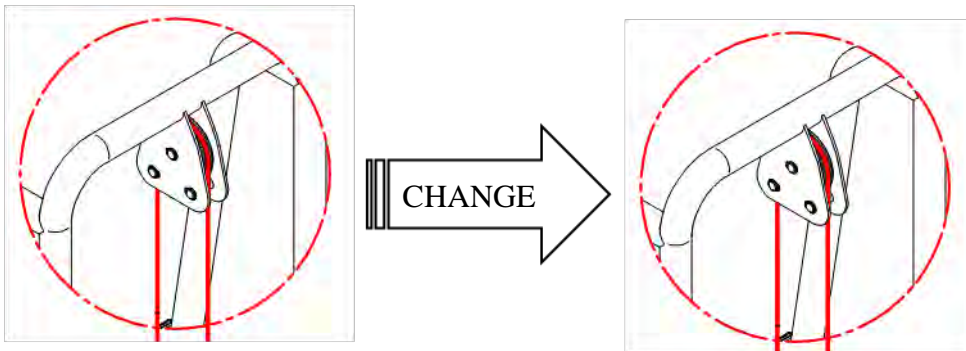



**4.4** ————— **YEARLY** 







**5**

**5.1**

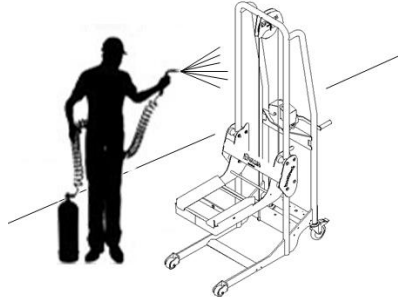
<p>1</p>	<p><b>H<sub>2</sub>O</b></p> <p><b>Max 30 bar</b></p>	
<p>2</p>		
<p>3</p>	<p><b>H<sub>2</sub>O</b></p> <p><b>5 bar</b></p>	
<p>4</p>		
<p>5</p>	<p><b>H<sub>2</sub>O</b></p> <p><b>5 bar</b></p>	

5.2

1	<p><b>O<sub>2</sub></b></p> <p><b>5 bar</b></p>	
2	 	
3	<p><b>H<sub>2</sub>O</b></p> <p><b>5 bar</b></p>	

6











USPUMS0919

ULMA Inoxtruck  
Paseo Obispo Otadui 10 · 20560 Oñati (Gipuzkoa)  
Tel: +34 943 848 943  
[info@ulmainoxtruck.com](mailto:info@ulmainoxtruck.com) · [www.ulmainoxtruck.com](http://www.ulmainoxtruck.com)