

DOUBLE SCISSOR LIFT TABLE Product Survey Sheet - EHLTD

Inquiry Date: _____ Due Date: _____

Contact: _____

Company: _____

Phone: _____

Fax: _____

E-mail: _____

PREVIOUS ORDER NUMBER OR QUOTE NUMBER, IF APPLICABLE:

PLATFORM SIZE Not Critical

Overall Width: _____

Overall Length: _____

Minimum Width: 34"

BASE WIDTH Not Critical

Width: 30"

Length: _____

Travel:

Lowered Ht.: _____

Raised Ht.: _____

Travel: _____

Table Capacity: _____

POWER (Check One)

____ 110VAC 1-Phase ____ 208/230VAC 1-Phase ____ Other

____ 208/230VAC 3-Phase ____ 460VAC 3-Phase

____ Rotary Air/Hydraulic (80 CFM @ 80 PSI, 1/2 GPM)

____ Washdown

____ UL or CSA Approved Electrical Components

____ No with Toeguards & Limiting Switches

____ No with no electrical Switches

____ No power unit

Controls: (HAND _____ FOOT _____ NONE _____)

Power Unit: EXTERNAL _____ INTERNAL _____

IF External - Length on Cords (8' STD) _____

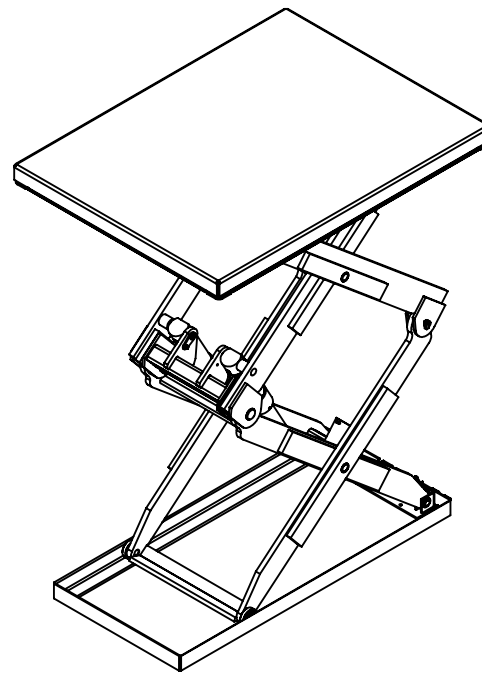

PRODUCT INFO

Load / Product type:
Basket / Pallet / Gaylord / Skid
Other: _____

Product Size:

Length: _____

Width: _____

Height: _____

Does container have feet? _____

Does container have drop sides? _____

Yes / No

Options:

____ Accordion Skirting (Bellows) ____ Special Color: _____ List Color: _____

____ Surface Mt. ____ Pit Mount (No Accordion Skirts on Pit Mt. units)

____ Portable

Additional options: _____

Pit Info:

____ Existing Pit ____ New Pit Construction

Pit Dimensions: _____

____ Reinforcing Angle ____ Dock Height / If Applicable: _____

Special Color/Paint:

"RAL" Number: _____

Manufacturer: _____

Color: _____

Type of Coating: _____

Application Information:

Is This a Hazardous Location? If YES: Class: _____ Div: _____ Group: _____

Number of shifts: _____

Special Temperature requirements: _____

Side Loading: _____

Special Loading and Unloading Requirements: _____

Additional Notes:

Quote options:

____ Exactly as specified ____ Cheapest / Closest to Vestil standard

____ Quickest to ship

Requested Delivery Date: _____

*All options may not be available on all models

Vestil Manufacturing Company * Angola, IN 46703 * Ph- 260-665-7586 * Fax- 260-665-1339