

Ground Lift Scissor Table Survey Sheet -EHLTG

Inquiry Date: _____ Due Date: _____

Contact: _____

Company: _____

Phone: _____

Fax: _____

E-mail: _____

PLATFORM SIZE

Not Critical

Overall Width: _____

Overall Length: _____

Usable Width: _____

Usable Length: _____

BASE WIDTH

Not Critical

Width: _____

Length: _____

Travel:

Lowered Ht.: _____

Raised Ht.: _____

Travel: _____

Table Capacity:

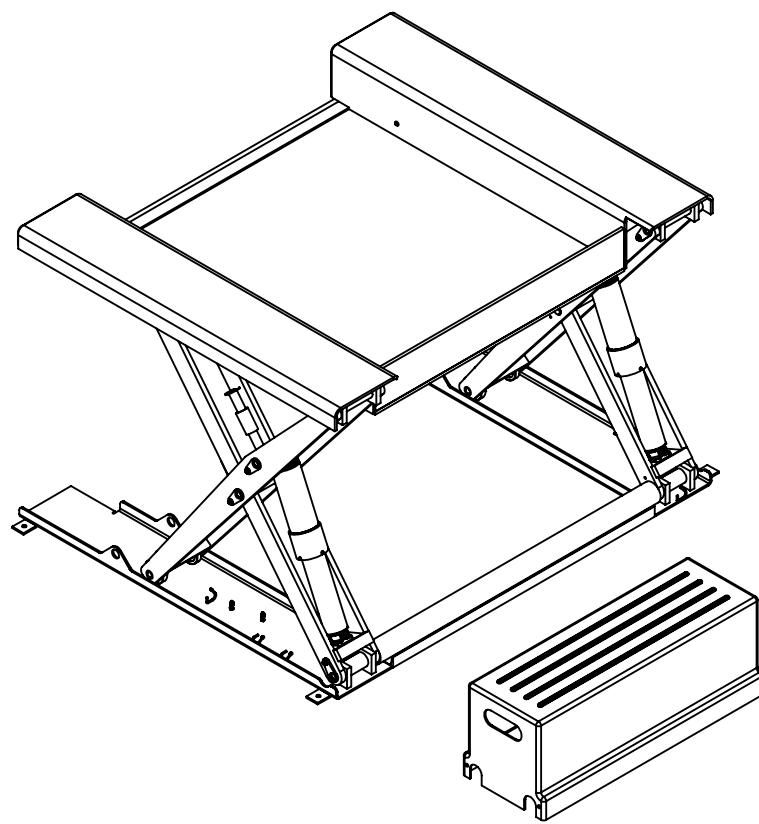

Previous Quote or Order #: _____

POWER (Check One)

_____ A/C (110V _____ 220V _____ 460V _____ Other _____)

_____ Single Phase

_____ Three Phase

_____ Air/Hydraulic

_____ Rotary Air / Oil

_____ No with no electrical Switches

_____ No power unit

Controls: (HAND _____ FOOT _____ NONE _____)

Remote Power Unit : 32 1/2" x 12" x 12 1/2" (L x W x H)
with 8' Hose and Cable

PRODUCT INFO

Load / Product type:

Basket / Pallet / Gaylord / Skid

Other: _____

Product Size:

Length: _____

Width: _____

Height: _____

Does container have feet? _____

Does container have drop sides? _____

Yes / No

Options:

_____ Accordion Skirting (Bellows) _____ 2 piece 3-Side _____ 1 piece 5-side

_____ Special Color: _____ RAL #: _____

_____ Surface Mt.

_____ Bridge Plate

_____ Handrails _____ Handrails w/ Toeboards size _____

_____ Conveyor _____ Ball Transfer Top

_____ Turntable _____ Manual Turntable _____ Power Turntable

Additional options: _____

Application Information:

Duty Cycle (High Cycle?): _____

Number of shifts: _____

Special Temperature requirements: _____

Minimum Working Temperature: _____

Side Loading: _____

Special Loading and Unloading Requirements: _____

Additional Notes: _____

Quote options:

_____ Exactly as specified _____ Cheapest / Closest to Vestil standard

_____ Quickest to ship

Requested Delivery Date: _____

*All options may not be available on all models