

STEEL SHEET LIFTER

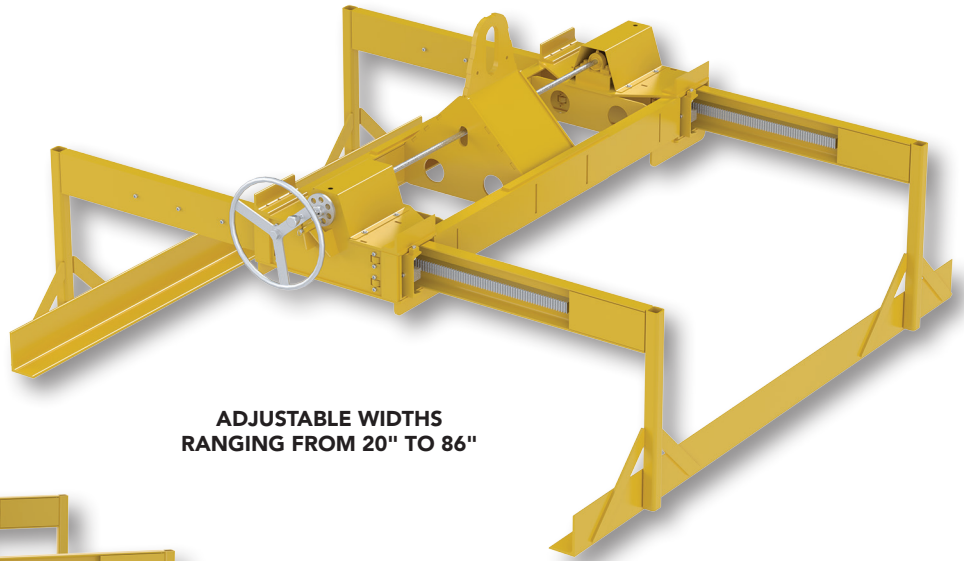

ADJUSTABLE WIDTHS
RANGING FROM 20" TO 86"

3"W x 7"H
BAIL OPENING

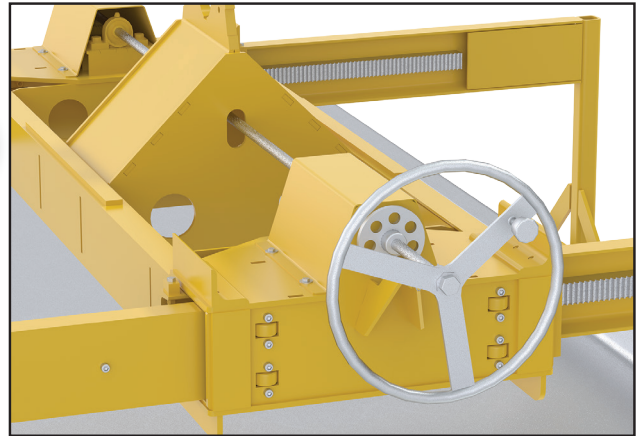
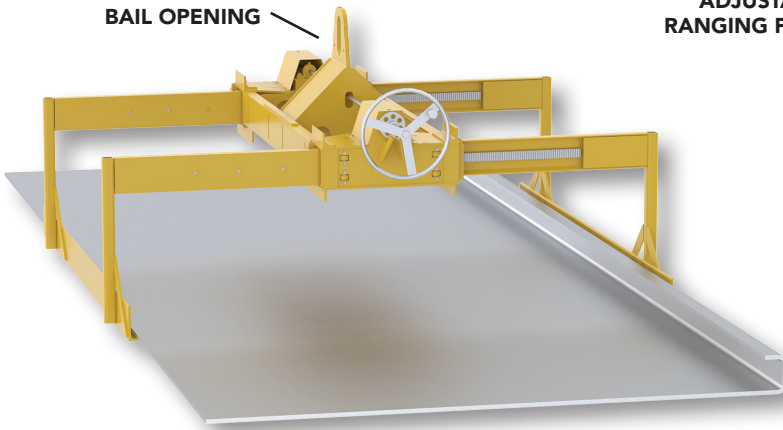

SELF-LOCKING
GEARED HANDLE

Standard Features:

- 10,000 lbs. capacity.
- Infinite adjustable widths ranging from 20" to 86".
 - Usable width ranges 28" to 72".
- Self-locking geared handle.
- Safely lifts bundles or individual sheets.
- Material must be stacked horizontally for proper handling.
- All steel construction with a yellow liquid paint finish.

MODEL NUMBER	OVERALL SIZE (W x L x H)	USABLE WIDTH	USABLE LENGTH	USABLE HEIGHT	MAXIMUM OPENING WIDTH	BAIL OPENING (W x H)	WEIGHT (LB)
SSL-2086-10	97 ³ / ₄ " x 98 ³ / ₁₆ " x 47 ³ / ₄ "	28" - 72"	96"	19 ⁷ / ₁₆ "	85 ³ / ₄ "	3" x 7"	1159

This lifter limits the amount of interaction between personnel and heavy sheets or plates of material!



Vestil Manufacturing Corporation
Larissa Flora - Sales Representative

2999 North Wayne Street, P.O. Box 570
Angola, Indiana 46703, USA

Phone: (260) 624-4341 Fax: (260) 665-1339
E-Mail: larissa@vestil.com Web: www.vestil.com